



Seiho International, Inc.

SUBMITTAL SHEET

www.seiho.com

Model: SFB

Dryer Vent

- Standard with Flapper Damper
- Large Free Area Reduce Clogging
- All Aluminum Construction

- Material: Aluminum
- Standard Finish: Clear Anodized

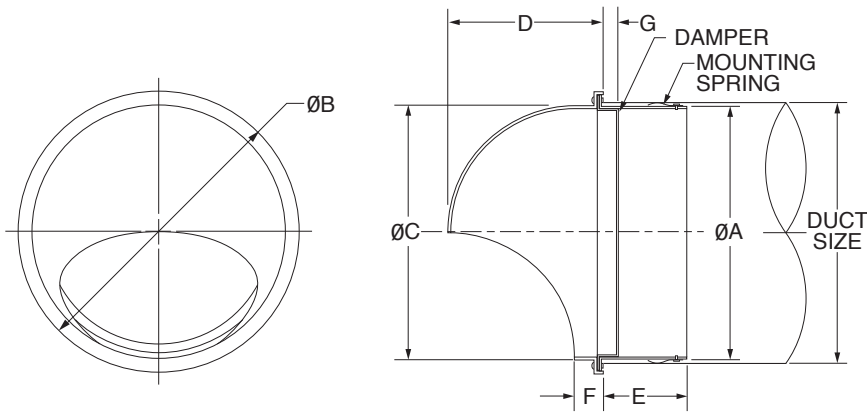

MODEL	DUCT SIZE	A	B	C	D	E	F	G	FREE AREA
SFB 4	4"	3 13/16	4 3/4	3 25/32	2 11/16	1 9/16	9/16	TBA	TBA
SFB 6	6"	5 23/32	6 29/32	5 29/32	3 15/16	2 9/16	3/4	3/4	0.13sq.ft

Product information is subject to change without notice. All dimensions in inches.

JOB NAME: _____
 LOCATION: _____
 ARCHITECT: _____
 ENGINEER: _____
 CONTRACTOR: _____

SUBMITTED BY: _____

DATE: _____

Model SFB
 Dryer Vent

Form No.422-22