

ASSEMBLING INSTRUCTION / MANUAL DE INSTALACIÒN / NOTICE D'INSTALLATION / ISTRUZIONI DI MONTAGGIO HEAVY-DUTY WALL BRACKETS / SOPORTES INDUSTRIALES / SUPPORTS INDUSTRIELS / STAFFE INDUSTRIALI

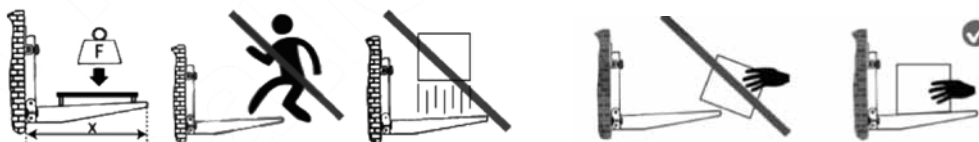
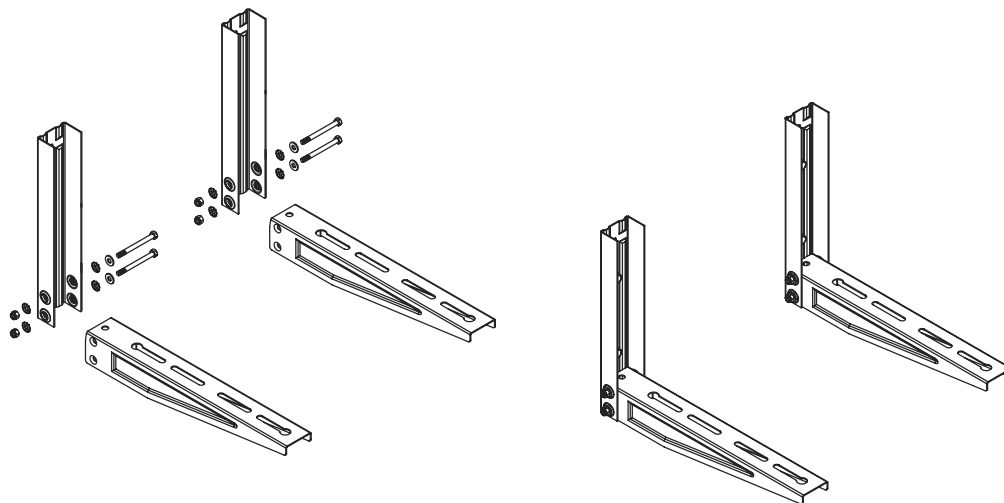

$X = 520$ mm (20") $F = 300$ kg / 660 lbs

$X = 560$ mm (22") $F = 300$ kg / 660 lbs

EN

HEAVY-DUTY BRACKETS

- Verify that the wall is suitable for the application. Avoid weak, veneered panel, perforated brick, or other unstable surfaces;
- Join the vertical and horizontal arms with the 2 screws, 4 washers, and 2 lock nuts provided;
- It is recommended that the installation be periodically inspected;
- Respect the indicated load capacity.

ES

SOPORTES INDUSTRIALES

- Controlar la pared que no tenga agujeros, que no sean paneles, de cartonyeso o ladrillos agujerados;
- Unir el brazo vertical al horizontal con los dos 2 tornillos (la fijación correcta es garantizada cuando el tornillo llega al final), de las 4 arandelas estriadas, las 4 arandelas plates y los dos dados auto-bloqueo;
- Aconsejamos un control periódico de la instalación;
- Respetar los pesos indicados.

FR

SUPPORTS INDUSTRIELS

- Vérifier le mur, évitant doublage, cloisons de plaque de plâtre et/ou de briques creuses;
- Assembler le bras vertical avec le bras horizontal en utilisant les 2 vis (la fin course du filet garantit une fixation correcte), les 4 rondelles dentées, les 4 plates et les 2 écrous autobloquants;
- Il est recommandé de vérifier périodiquement l'installation;
- Respecter les portées indiquées.

I

STAFFE INDUSTRIALI

- Verificare la parete, evitando rifodere, pannelli, pareti in cartongesso e/o mattoni forati;
- Unire il braccio verticale a quello orizzontale tramite l'inserimento delle 2 viti (il fissaggio corretto è garantito dal fine corsa del filetto), delle 4 rondelle dentate, 4 rondelle piane e dei 2 dati autobloccanti,
- Si consiglia una verifica periodica dell'installazione;
- Rispettare le portate indicate.