

METRO 120ERV-ECM

ENERGY RECOVERY VENTILATOR



ENGINEERING DATA

TOTAL RECOVERY CORE

Cross-flow energy recovery core transfers heat and water vapor between two air-streams. Easily removed for cleaning or service.

MOTORS AND BLOWERS

Each airstream has an independent centrifugal blower with ECM motor with multiple fan speed operations.

FILTERS

Washable antimicrobial MERV 6 air filters in exhaust and supply air streams.

MOUNTING

Mounting brackets supplied

FROST PREVENTION

Temperature sensor activated, periodically shuts down supply motor. Drains not required.

CASE

Twenty gauge prepainted galvanized steel for superior corrosion resistance. Insulated to prevent exterior condensation.

ELECTRONICS

Main control can be wall mounted in a central location. 3 wire 20 gauge (min.) 100 ft. length (max.)

OPTIONAL ACCESSORIES:

TechGrille
99-EAG4
99-EAG5
99-EAG6
99-EAG8



Terminator Fitting
99-TM4
99-TM5
99-TM6



Wireless 20/40/60 Min Timer
99-DET02



Dual Hood
99-190
99-194



Weather Hoods
99-185
99-186
99-187



LIFEBREATH CONTROL OPTIONS

FEATURES	99-DXPLO2	99-BC02	99-BC03	99-BC04
5 speed fan operation on each mode	✓			
2 speed fan operation (Low/High)		✓		✓
Continuous low speed fan operation				
Humidity control through adjustable Dehumidistat	✓	✓	✓	
Large digital LCD screen	✓			
LED status indicator lights		✓	✓	✓
Continuous Ventilation	✓	✓	✓	✓
Continuous Recirculation				
20 ON/40 OFF	✓		✓	✓
10 ON/50 OFF	✓			
20 ON/40 Recirculation				
20/40/60 min. High speed override button	✓			
Compatible with 99-DET02 Wireless Timer	✓	✓	✓	✓
3 wire connection	✓	✓	✓	✓

TIMER OPTIONS

99-DET01 - Lifebreath 20/40/60 Minute Timer
Initiates high speed Ventilation for 20, 40 or 60 minutes. 3 wire connection.

99-DET02
Wireless Lifebreath 20/40/60 Minute Timer
Initiates high speed Ventilation for 20, 40 or 60 minutes. Wirelessly connects to main control for ease of installation. 40' approximate range. Exclusive to Lifebreath.

99-RX02 - Wireless Lifebreath Repeater
Extends range of 99-DET02 Wireless Timers. Plugs into 120V power outlet. Wirelessly connects to main control and 99-DET02. Install at halfway point between timer and main wall control if timer is out of range.



99-DXPLO2



99-DET02

METRO 120ERV-ECM

ENERGY RECOVERY VENTILATOR



PERFORMANCE (HVI CERTIFIED)

IN. W.G. (PA)	0.1 (25) CFM (L/s)	0.2 (50) CFM (L/s)	0.3 (75) CFM (L/s)	0.4 (100) CFM (L/s)	0.5 (125) CFM (L/s)	0.6 (150) CFM (L/s)	0.7 (175) CFM (L/s)	0.8 (200) CFM (L/s)
Net Supply Airflow	131 (62)	124 (58)	116 (55)	108 (51)	98 (46)	87 (41)	74 (35)	58 (27)
Gross Supply Airflow	132 (63)	125 (59)	118 (56)	109 (52)	100 (47)	88 (42)	75 (35)	59 (28)
Gross Exhaust Airflow	130 (61)	122 (57)	116 (55)	110 (52)	103 (49)	93 (44)	78 (37)	57 (27)

ELECTRICAL SPECIFICATIONS	
VAC @ 60Hz	120
Watts / Low Speed	22
Watts / High Speed	74
Amp Rating	1.4

			WATTS/ CFM
Sensible Effectiveness (ASE) @ 50 CFM (23 L/s)	32°F (0°C)	80%	.440
Sensible Efficiency (SRE) @ 64 CFM (30 L/s)	32°F (0°C)	71%	.406
Sensible Efficiency (SRE) @ 50 CFM (23 L/s)	32°F (0°C)	73%	.440
Total Efficiency (TRE) @ 50 CFM (23 L/s)	95°F (35°C)	52%	.440

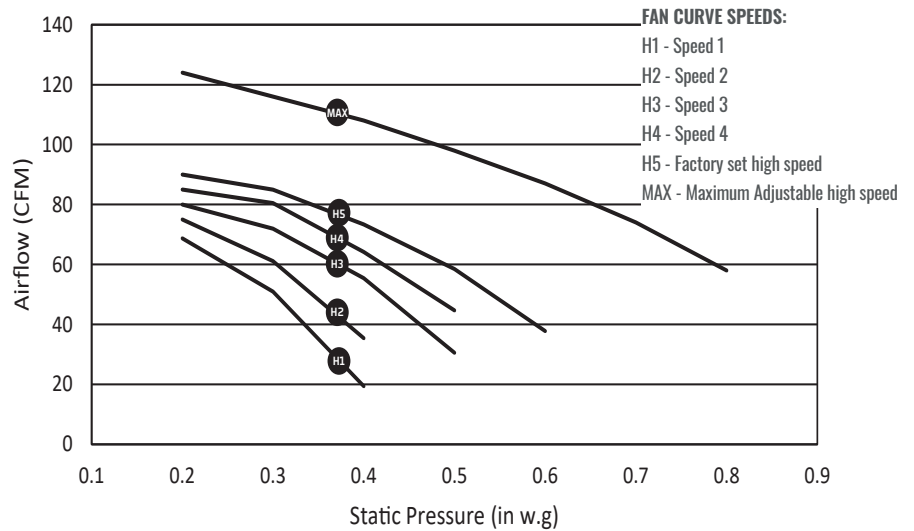

WEIGHT:
57 LBS (25.8 KG)

SHIPPING WEIGHT:
67 LBS (30 KG)

NOTE:
Front clearance of 25 in. (635 mm) is recommended for servicing unit.



DIMENSIONS

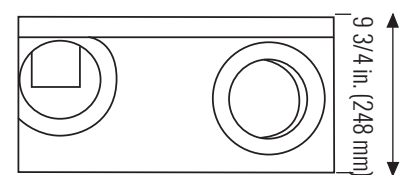
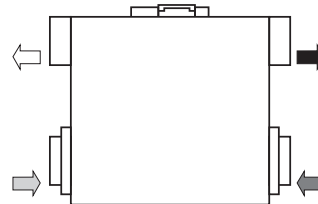
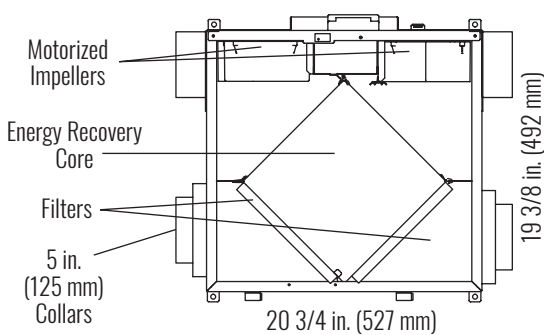

- Stale air to outside
- Fresh air from outside
- Stale air from inside
- Fresh air to inside

Date: _____
 Tag: _____
 Project: _____ Qty: _____
 Engineer: _____
 Control: _____

Contractor: _____
 Supplier: _____
 Quote #: _____
 Submitted By: _____
 Timer: _____ Timer Qty: _____

WARRANTY

Units carry a 5 year warranty on the enthalpic (ERV) core and a 5 year replacement parts warranty.

All units conform to CSA and UL standards



www.lifebreath.com