

ENGINEERING DATA

CORES

Modular (2 section) patented aluminum heat recovery cores arranged for efficient counter-flow ventilation.

MOTORS

Two PSC, 3 speed single shafted, 120 VAC, 4.5 Amps each (9 total on high speed). HP-1/4, 1450 RPM. MCA: 11.3 MOP: 15 Watts - total on high speed - 1032.

FILTERS

Washable air filters in exhaust and supply air streams.

BLOWERS

Centrifugal type rated at 700 CFM (329 L/s) free air delivery. Each air stream has one single shafted motor driving a centrifugal blower.

CONNECTION DUCT SIZES - Four - 14" x 8" (356 mm x 200 mm).

MOUNTING

Unit to be set on support brackets hung by threaded rod type apparatus (brackets and rods not provided).

CASE

Unit has front and back access doors and electrical panel can be switched to either side giving installer flexibility in duct direction. 20 gauge prepainted galvanized steel (G60) for superior corrosion resistance. Insulated with foil faced insulation where required to prevent exterior condensation. Drain connections; two - 1/2" (12 mm) O.D.

ELECTRONICS

Integrated microprocessor circuit board. Built-in interlock contacts. Automatic Self Test. Optional remote speed control.

DEFROST CONTROLS

MODEL 700FD - Interrupts supply air while exhaust air defrosts core.
MODEL 700DD - Supply bypass routes indoor air to defrost core.

WEIGHT 260 LBS (118 KG) **SHIPPING WEIGHT** 310 LBS. (141 KG)

OPTIONAL CONTROLS

99-500 3 Speed Control - 3 Speed Fan setting (Low/Medium/High) (4 wire) 20 gauge wire (minimum)

99-BC-01 Ventilation Control - 2 Speed Fan setting (Low/High) - Dehumidistat (3 wire) 20 gauge wire (minimum)

OPTIONAL TIMERS

99-DET01 20/40/60 Minute Timer - Initiates high speed ventilation for 20, 40, 60 minutes. (3 wire) 20 gauge wire (minimum)

99-20M01 20 Minute Timer - Initiates high speed ventilation for 20 minutes. (3 wire) 20 gauge wire (minimum)

DIMENSIONS inches (mm)

NOTE:
The 700FD/DD model may easily be reversed in the field. Refer to page 22 for installation instructions.

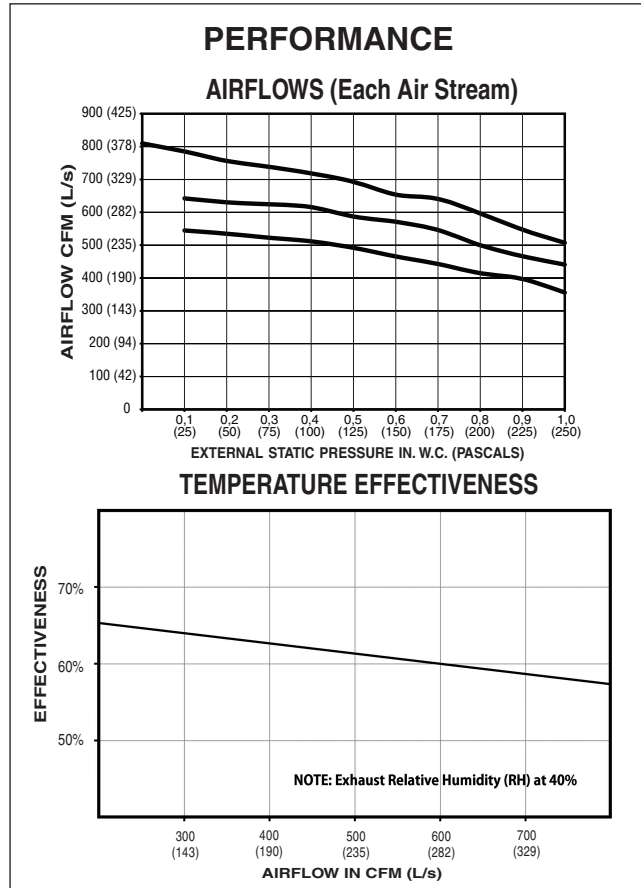
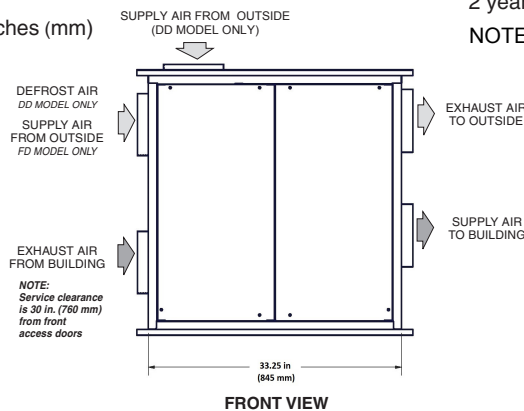

OPTIONAL ACCESSORIES

99-DH-01 Remote Wall Dehumidistat - Initiates high speed ventilation when the indoor humidity level is above the set point. (3 wire) 20 gauge wire (minimum)

OPTIONAL FILTERS

99-65-183 2" pleated MERV 8 filter for fresh air stream.

WARRANTY

All units carry a 15 year warranty on the heat recovery cores and a 2 year replacement parts warranty.

NOTE: All specifications are subject to change without notice

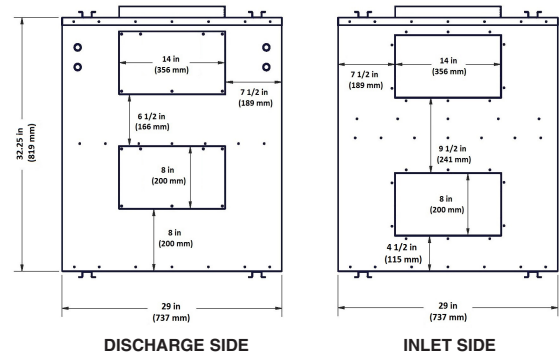

Date: _____

Tag: _____ Qty: _____

Project: _____

Engineer: _____

Contractor: _____

Supplier: _____

Quote#: _____

Submitted by: _____