

Model 2500IFD

AIR FLOW

2500 cfm (1175 L/s) at 1.0" wg ESP

PERFORMANCE

70% effective at 2500 cfm (1172 L/s)

CORE

Modular aluminum sensible heat recovery core. Plate-to-plate type. Slides out of either side of cabinet for service.

MOTORS

Two single shaft PSC, 3-speed, 240 Vac, 6.5 amps, 1ph, 1hp, 3 speed motor (2 speeds available; 13.0 amps total). MCA: 16.3 MOP: 20

BLOWERS

Two direct-drive centrifugal blowers, one per air stream.

FILTERS

Two 18" X 24" (457 mm x 610 mm) 4-inch pleated filters in each air stream.

DUCT CONNECTIONS

Four 24" X 16" (610mm X 406mm)

CABINET

20 gauge powder coated galvanized steel (G60) for superior corrosion resistance. 16 gauge galvanized frame, insulated with 1.0" fiberglass insulation to prevent condensation.

DRAIN

Two stainless steel drain pans with 1/2" (12 mm) NPT drain spouts.

MOUNTING

Unit can be set on floor or on support brackets hung by threaded rod type apparatus. Brackets and rod not provided.

CONTROLS

Integrated microprocessor board, optional remote 2 speed control, built in interlock contacts.

DEFROST

Factory set defrost time. Supply motor is shut off while exhaust air defrosts core. Two defrost times available.

WEIGHT 680 lbs. **SHIPPING WEIGHT** 900 lbs.

OPTIONAL CONTROLS

99-BC01 Ventilation Control - 2 Speed Fan setting (Low/High) - Dehumidistat (3 wire) 20 gauge wire (minimum).

OPTIONAL TIMERS

99-DET01 20/40/60 Minute Timer - Initiates high speed ventilation for 20, 40 or 60 minutes. (3 wire) 20 gauge wire (minimum)

99-20M01 20 Minute Timer - Initiates high speed ventilation for 20 minutes. (3 wire) 20 gauge wire (minimum).

OPTIONAL ACCESSORIES

99-DH01 Remote Wall Dehumidistat - Initiates high speed ventilation when the indoor humidity level is above the set point. (3 wire) 20 gauge wire (minimum)

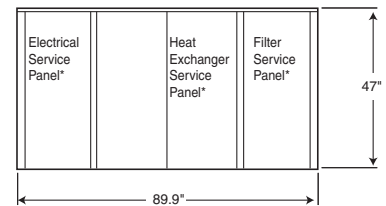
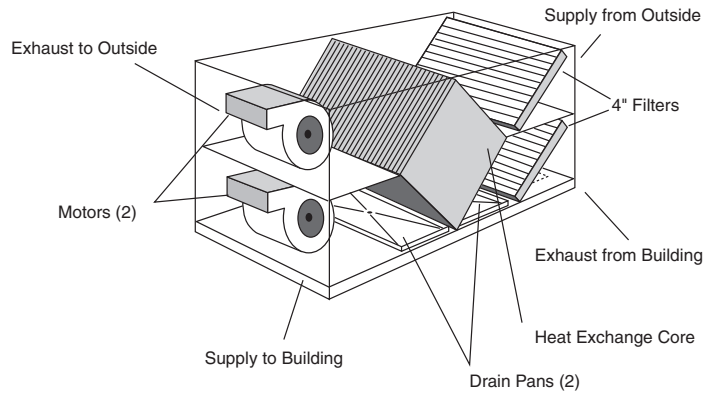

SIDE VIEW

*NOTE: Removable service access panels on both sides of 2500IFD cabinet.

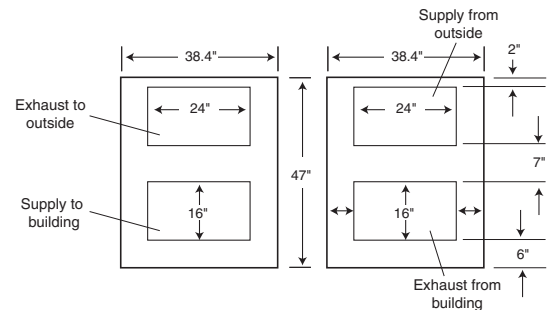

FRONT VIEW

BACK VIEW

Service clearance - 42" on electrical panel side

WARRANTY

All units carry a 15 year warranty on the heat recovery cores and a 2 year replacement parts warranty.

All units conform to CSA and UL standards.

NOTE: All specifications are subject to change without notice.

Date: _____

Contractor: _____

Tag: _____ Qty: _____

Supplier: _____

Project: _____

Quote#: _____

Engineer: _____

Submitted by: _____



511 McCormick Blvd.
London, Ontario N5W 4C8
T 1-855-247-4200
F 1-800-494-4185
Email: info@lifebreath.com

270 Regency Ridge, Suite 210
Dayton, Ohio 45459
T (937) 439-6676
F (937) 439-6685
Website: www.lifebreath.com



TI-911
0709