

SPECIFICATIONS

AIRFLOW

1500 cfm (705 L/s) at 1.0" wg ESP.

PERFORMANCE

65% effective at 1500 cfm (705 L/s).

CORES

Six patented aluminum heat recovery cores arranged for efficient cross-flow ventilation.

MOTORS

Two single shaft ECM variable speed, 240V, 9.1 A, MCA: 22.8 MOP: 30 1 ph, 1 hp. (18.2 A total)

BLOWERS

Two direct drive centrifugal blowers, one per airstream.

FILTERS

Two - 20" x 16" x 2" (508 mm x 406 mm x 50 mm) pleated filters in each airstream. MERV6 efficiency 60% @ 4.69 microns.

DUCT CONNECTIONS

Two 19" x 16" (482 mm x 406 mm) to and from building under cabinet.
Two 18" x 17" (457 mm x 431 mm) hoods included on side of cabinet with washable screens.

CABINET

20 gauge powder coated steel insulated 1" (25 mm) thick Elastomeric insulation.

DRAIN

Two powder coated galvanized steel drain pans with 1/2" (12 mm) O.D. drain connections.

MOUNTING

Rooftop mounted on optional roof curb. (Part No. 53-1500)

ELECTRONICS

Integrated microprocessor circuit board. Three (3) independently adjustable motor speeds.

OPTIONAL CONTROLS

99-BC01 Ventilation Control - 2 Speed Fan setting (Low/High) - Dehumidistat (3 wire) 20 gauge wire (minimum).

99-500 3 Speed Control - 3 Speed Fan setting (Low/Medium/High) - (4 wire) 20 gauge wire (minimum).

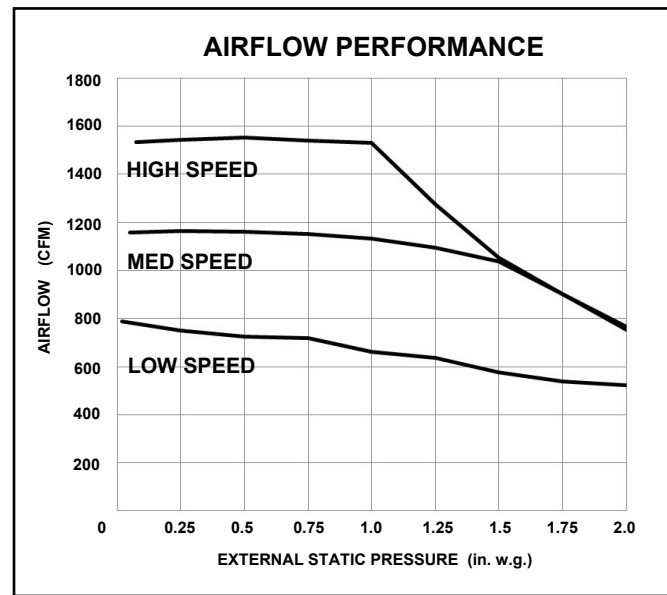

OPTIONAL TIMERS

99-DET01 20/40/60 Minute Timer - Initiates high speed ventilation for 20, 40 or 60 minutes. (3 wire) 20 gauge wire (minimum)

99-20M01 20 Minute Timer - Initiates high speed ventilation for 20 minutes. (3 wire) 20 gauge wire (minimum).

OPTIONAL ACCESSORIES

99-DH01 Remote Wall Dehumidistat - Initiates high speed ventilation when the indoor humidity level is above the set point. (3 wire) 20 gauge wire (minutes)

DEFROST

Factory set defrost time. Supply motor is shut off while exhaust air defrosts core.

WEIGHT 530 lbs (240 kg) **SHIPPING WEIGHT** 650 lbs (290 kg)

WARRANTY

All units carry a 15 year warranty on the heat recovery cores and a 2 year replacement parts warranty.

NOTE: All specifications are subject to change without notice.

DIMENSIONS 1500E-ECM (in inches)

	A	B	C	D	E	F	G	H	I	J	K	L	M	N
EFD inches	20	1.5	17	16.5	41	69.5	20	17	14.5	1.5	20	44	46.5	67
EFD mm	508	38	432	419	1041	1765	508	432	368	39	508	1118	1181	1702

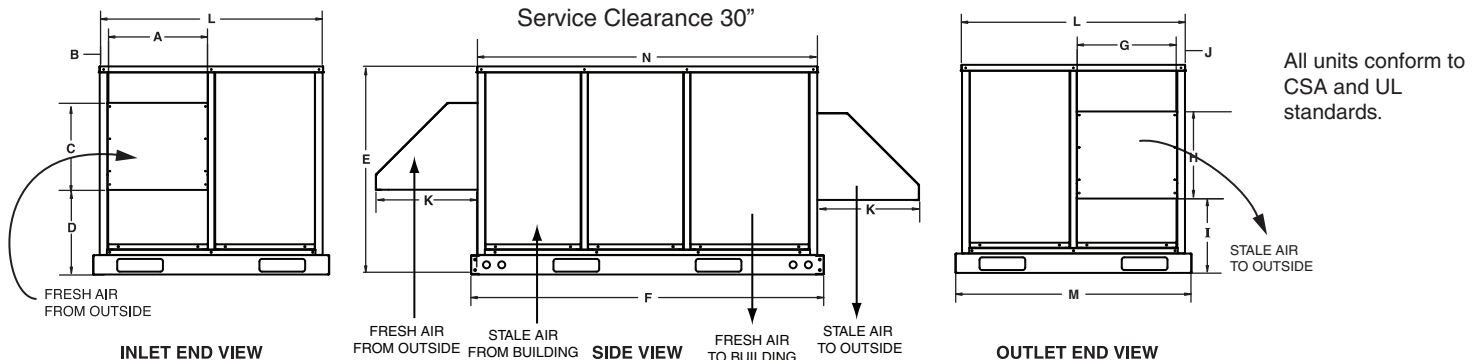

Date: _____
 Tag: _____ Qty: _____
 Project: _____
 Engineer: _____

Contractor: _____
 Supplier: _____
 Quote#: _____
 Submitted by: _____