

TRI-LITE HVLS SERIES CEILING FANS

INSTALLATION INSTRUCTIONS

PLEASE READ AND SAVE THESE INSTRUCTIONS



BEFORE YOU BEGIN

Your kit should include all of the components shown below.

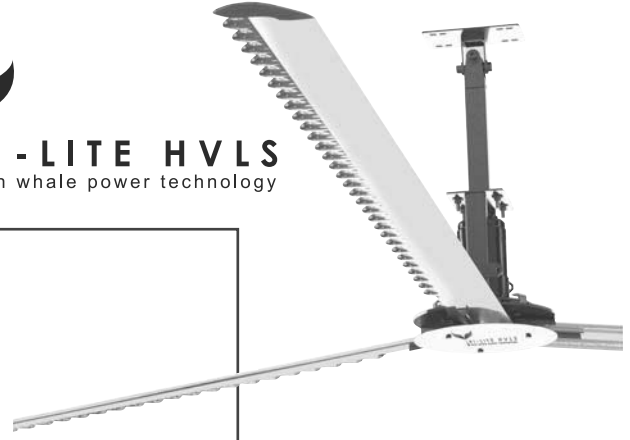

FAN COMPONENTS

- (4) Bolts M14-2.0 x 54mm
- (8) Washers Flat M14
- (4) Nylocks M14-2.0

Standard Mount:
(Available in approx
300mm, 600mm or
1220mm lengths,
custom lengths are
optional)

See Cable Detail
Drawing

Extension

Fan Drive Assembly
(Includes Hub)

Note: All bolts are
"Class 8.8"
FT= Fully Threaded
(#) = Quantity Supplied

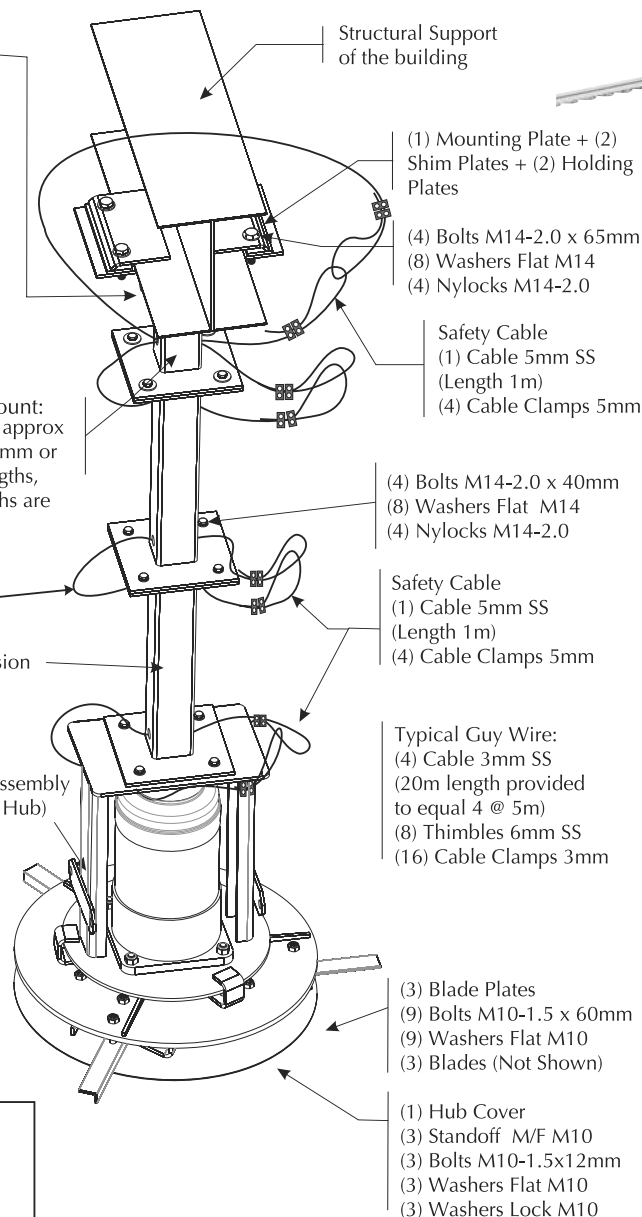

CABLE DETAIL

NOTE: HVLS blades are not shown in the assembly to allow greater detail of parts. See **Figure 14** for finished assembly.

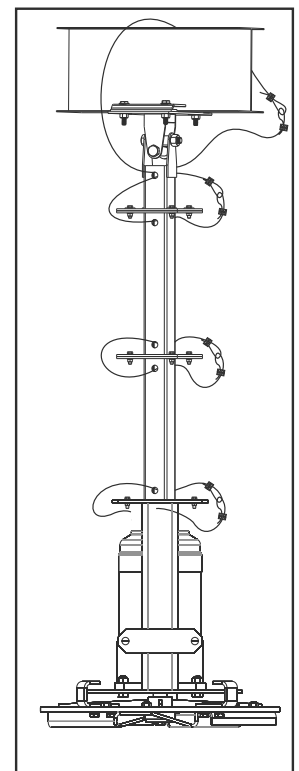

TOOLS REQUIRED TO INSTALL PRODUCT

- Level
- Cable cutters (for stainless steel aircraft cable)
- Ratchet or impact gun
- Basic imperial socket set up to 7/8" will fit bolt heads and nuts
- Basic imperial wrench set up to 7/8" will fit bolt heads and nuts
- Lifting device or scaffolding

REQUIRED STEPS BEFORE INSTALLATION

- Check to see if you have all of the tools required for the installation.
- Verify that all fan components were received.
- Check drawings and layouts provided to locate where the Tri-Lite HVLS Fan is to be installed.
- Ensure work area is safe and that all security, policies and procedures for the facility are met.
- Inspect the lift device or mobile platform.
- Each person installing the Tri-Lite HVLS Fan must use a safety harness at all times.
- Other safety requirements may be required for installation.
- All workspace safety requirements, lock out procedures and hoarding of construction zone for the assembly and installation must be met and followed.

DIFFERENT MOUNTING APPLICATIONS

NOTE: The following mounting applications are representations only and are subject to change without notice. Contact your Canarm sales representative for complete mounting instructions.

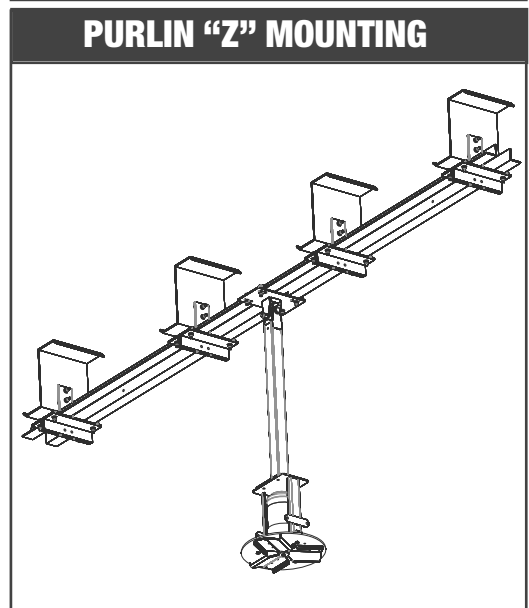
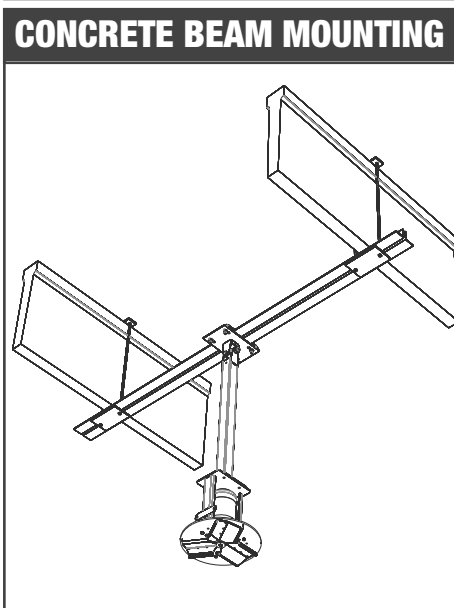
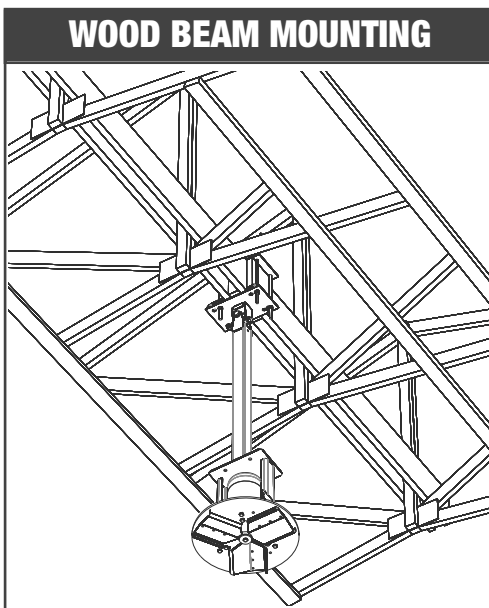
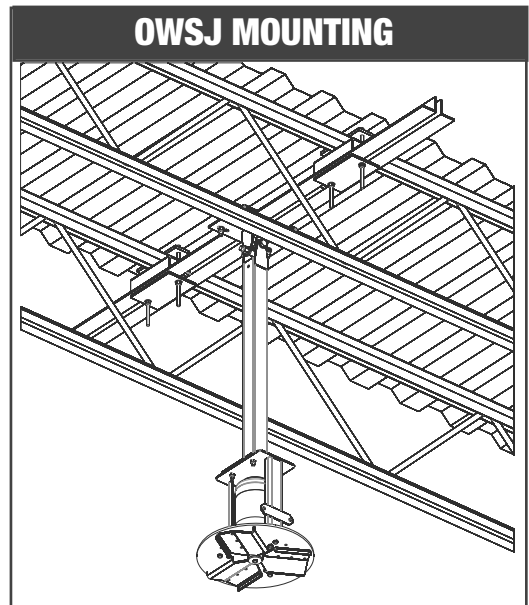
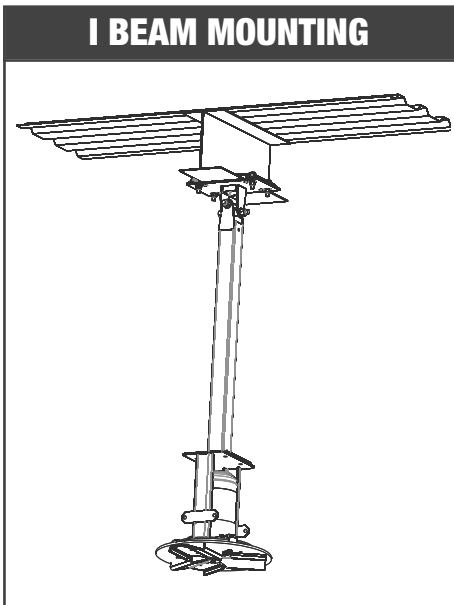

STANDARD MOUNT

A Standard Mount package is used with all Tri-Lite HVLS Fans assemblies (except “Wood” Beam Mounting). See **Figure 1**.

Standard drop mounts of approximately 1’, 2’ and 4’ are available.

The package includes:

- (2) mfg “I” Beam clamps
- (2) mfg “I” Beam spacers (may or may not be required for assembly)
- (1) Upper Pivot Plate
- (1) Upper Pivot (pre-assembled)
- (1) Stem for 1’, 2’ and 4’ packages
- (4) Bolts, Nuts & Washers
- (1) Cable 5mm SS (Length 6.5’)
- (4) Cable Clamps 5mm (not shown)

NOTE: Spacer may or may not be required. This is dependent upon the thickness of the support structure.

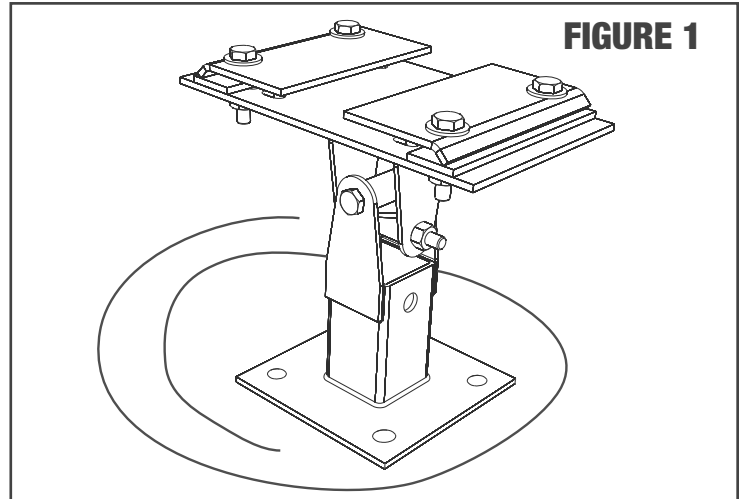

FIGURE 1

INSTALLING THE MOUNT

1. Sandwich the “I” Beam or OWSJ Beam between the mfg “I” Beam clamps and the upper pivot plate. Insert the mfg “I” Beam spacers if required.
2. Insert the bolts, washers and tighten the nylocks (**Figure 2**).
3. Position the safety cable as per **Figure 2**, loop at both ends.
4. Using a 7/16” wrench, fasten cable clamps as typical cable clamp installation (**Figure 3**). Cable should be relatively snug.

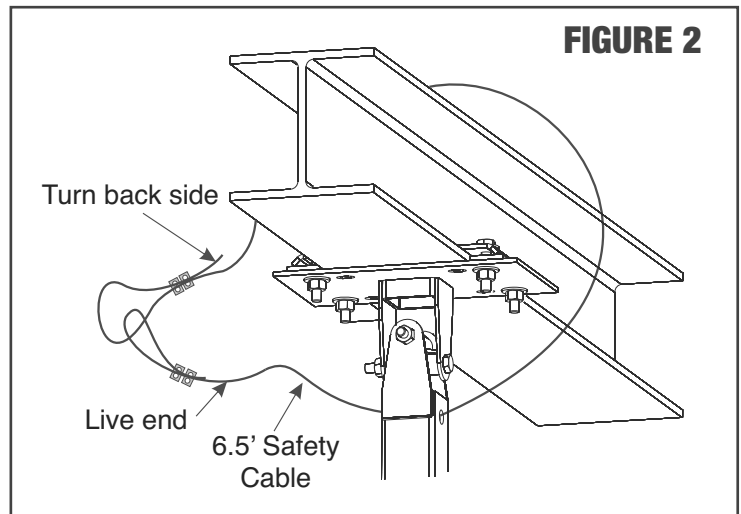

FIGURE 2

TYPICAL CABLE CLAMP INSTALLATION

When placing cable clamps on the wire, it is imperative that the U-bolt side of the clip is placed on the short turn back side and the saddle goes on the long side (the “live” end).

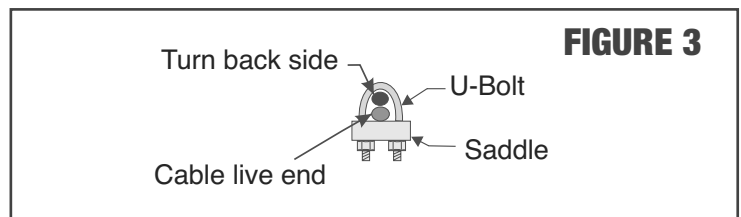

FIGURE 3

EXTENSIONS

The package includes:

- (1) Extension (standard 2’ or 4’)
- (4) Bolts M14-2.0 x 36mm
- (8) Washers Flat M14
- (4) Nylocks M14-2.0
- (1) Cable 5mm SS (Length 3.3’)
- (4) Cable Clamps 5mm

Depending on your assembly, your package may include an extension. The extension with the standard mount will make up the overall drop length.

If a specific drop distance is required, a custom extension may be an option and can be ordered.

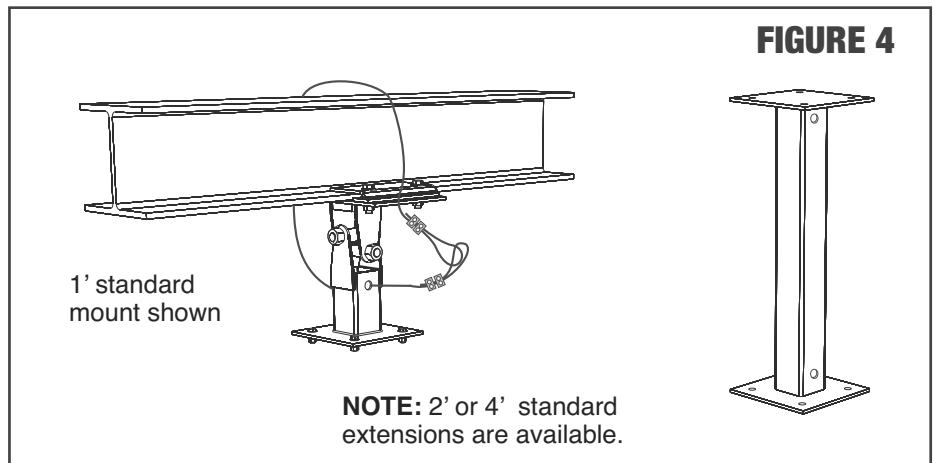

FIGURE 4

NOTE: You are only allowed to use a maximum of two extensions per assembly!

INSTALLING THE EXTENSION

1. Using a 7/8" wrench, fasten top plate of extension to the bottom plate of the standard mount using M14 bolts, nuts and washers.
2. Position the safety cable as per **Figure 5**, loop at both ends.
3. Using a 7/16" wrench, fasten the cable clamps 2 per end and as per typical cable clamp installation (**Figure 3**). Cable should be relatively snug.

NOTE: Every connection between components (mounts, extensions and fan frame) must include a safety cable as shown throughout this manual, loop at both ends.

MAIN HUB AND DRIVE ASSEMBLY

(Figure 6)

The package includes:

- (1) Hub
- (1) Fan Frame
- (1) Safety Washer & Bolt
- (1) Gear Motor
- (3) Safety Clips

- (4) Bolts M14-2.0 x 40mm
- (8) Washers Flat M14
- (4) Nylock M14-2.0
- (1) Cable 5mm SS (Length 3.4')
- (4) Cable Clamps 5mm

INSTALLING THE MAIN HUB & DRIVE ASSEMBLY

1. Using a 7/8" wrench, fasten the top plate of fan frame to the bottom plate of the standard mount using M14 bolts, nuts and washers.
2. Position the safety cable as per **Figure 7**, loop at both ends.
3. Using a 7/16" wrench, install and fasten cable clamps 2 per end as per **Figure 3**. Cable should be relatively snug.

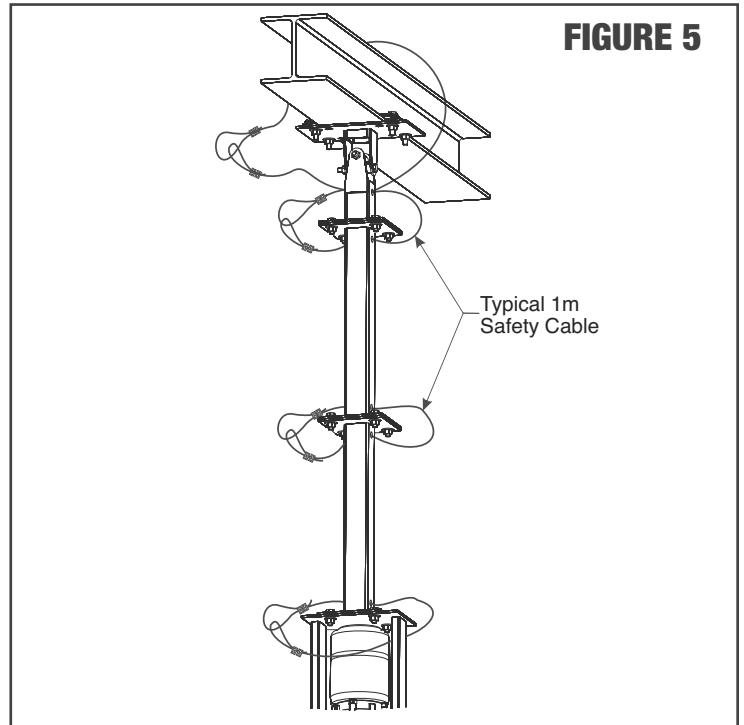

FIGURE 5

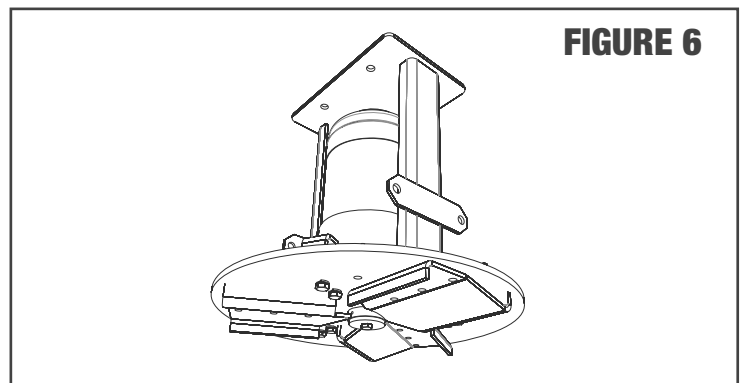

FIGURE 6

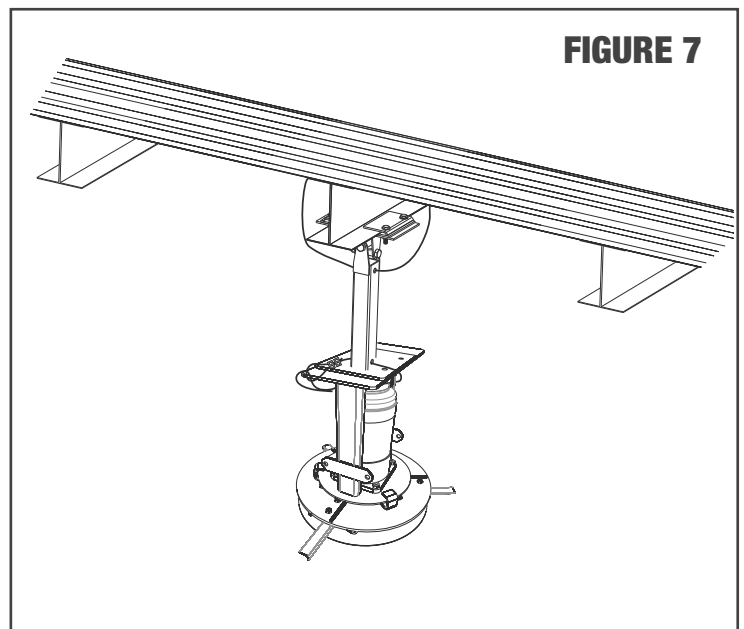

FIGURE 7

GUY WIRES

The package includes:

- (4) Cable 3mm SS (66' length provided to equal 4 @ 16.5')
- (8) Thimbles 6mm SS
- (16) Cable Clamps 3mm

Extra hardware required:

- (4) Forged Eye Bolts M6-1.0 x 100mm
- (4) Nuts M6-1.0
- (4) Nylocks Mg-1.0
- (8) Washers Flat M6

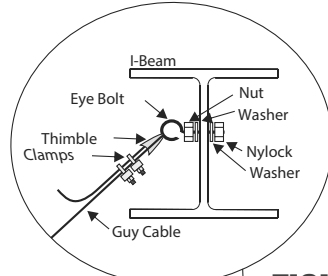

FIGURE 8

DO NOT USE TURNBUCKLES

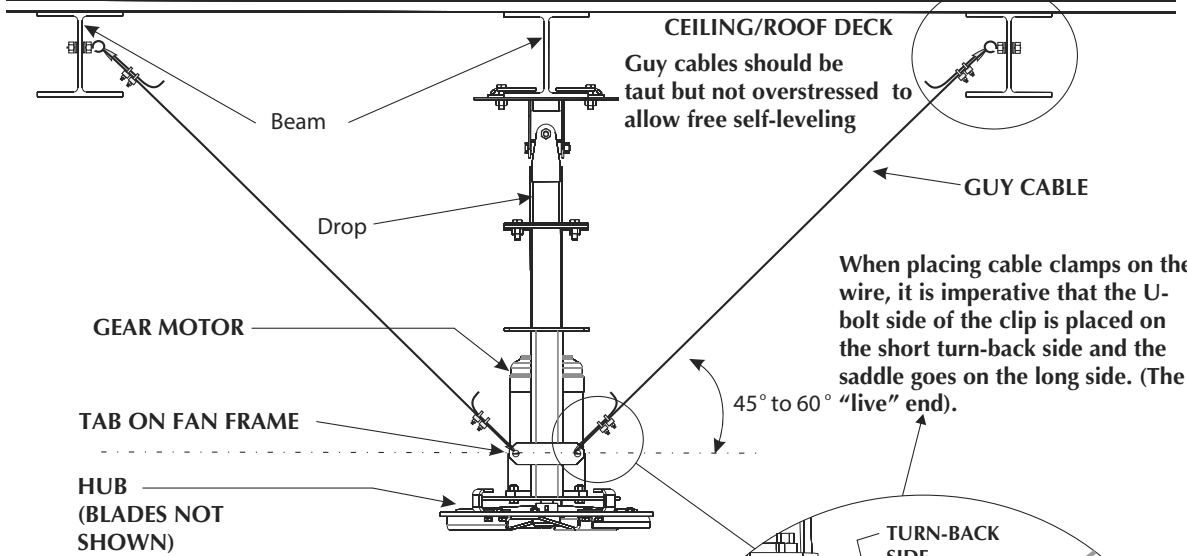

FIGURE 9

When placing cable clamps on the wire, it is imperative that the U-bolt side of the clip is placed on the short turn-back side and the saddle goes on the long side. (The 45° to 60° "live" end).

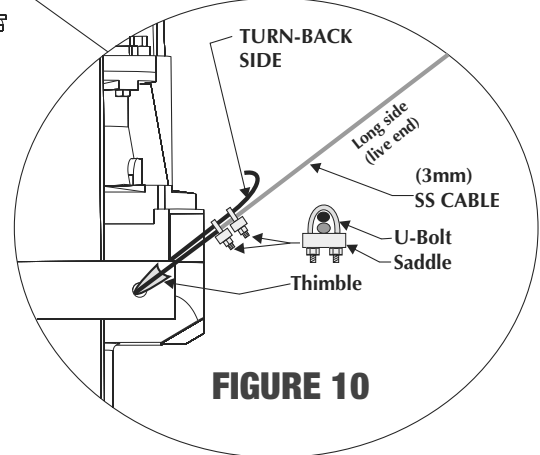
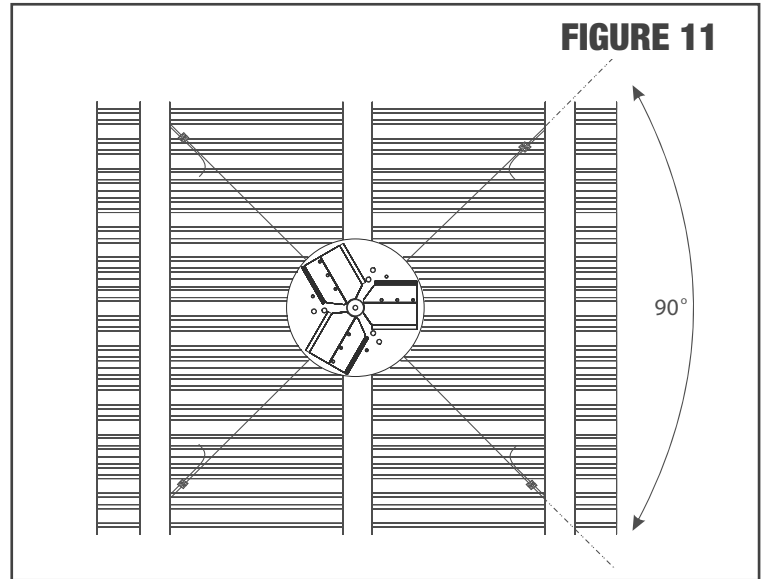

FIGURE 10

STRUCTURAL NOTE: Guy cables must be installed or fastened to a structural component of the building at the angle shown in **Figure 9** and **Figure 11**.

INSTALLING GUY WIRES

1. Determine mounting position on ceiling and establish the angle between 45° - 60° for the cable. Determine correct location on the I Beam to drill 5/16" diameter hole for the eye bolt. For example, if fan is 3.3' down from ceiling, cables should be mounted approximately 3.3' away from fan.
2. Using a 3/8" wrench, install eye bolt with nuts and washers in I Beam as per **Figure 9**.
3. Measure the run of cable required and cut cable approximately 2' longer. **NOTE:** longer runs than 14' will require additional cable.
4. Secure it with 1 thimble and 2 cable clamps (**Figure 10**). Repeat using the other 3 pieces of guy wire cables, thimbles and cable clamps (**Figure 10**).
5. Guy wires should be taut but not over-stressed to allow free self-levelling. They should also be to approx. 90° apart (**Figure 11**).



NOTE: Fans hanging lower than 10' will require additional cable.

IMPORTANT LEVELLING INSTRUCTIONS:

Check to see if the fan is level by placing your level vertically on the side of the fan frame. If adjustment is needed, slightly tighten the guy wires on the appropriate side.

BLADE ASSEMBLY

The assembly includes:

- (3) Blade Plates
- (9) Bolts M10-1.5 x 60mm
- (9) Washers Flat M10
- (3) Blades

INSTALLING THE BLADE ASSEMBLY

1. Using a 5/8" wrench, clamp a blade between blade plate and hub using M10 bolts and washers. There are 3 bolts per blade.
2. Continue until all 3 blades have been fastened and tighten down.
3. Turn the fan by hand to ensure that there are no obstructions with the blades.

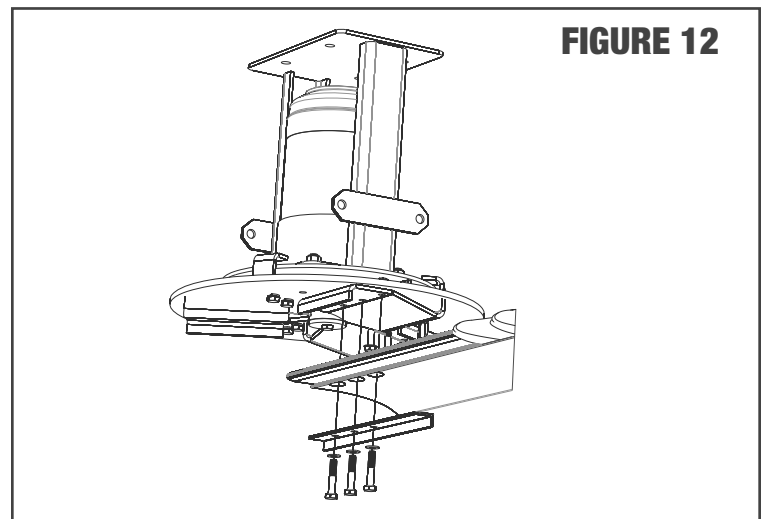

HUB COVER

The assembly includes:

- (1) Hub Cover
- (3) Standoff M/F M10
- (3) Bolts M10-1.5x12mm
- (3) Washers Flat M10
- (3) Washers Lock M10

1. Line up the holes in the stando attached to the fan frame with the holes in the bottom of the hub cover.
2. Using M10 bolts with a lock washer and a flat washer, thread each M10 bolt into each of the holes in the hub cover and standoffs.
3. Tighten bolts with a 5/8" wrench and make sure hub cover is secure.

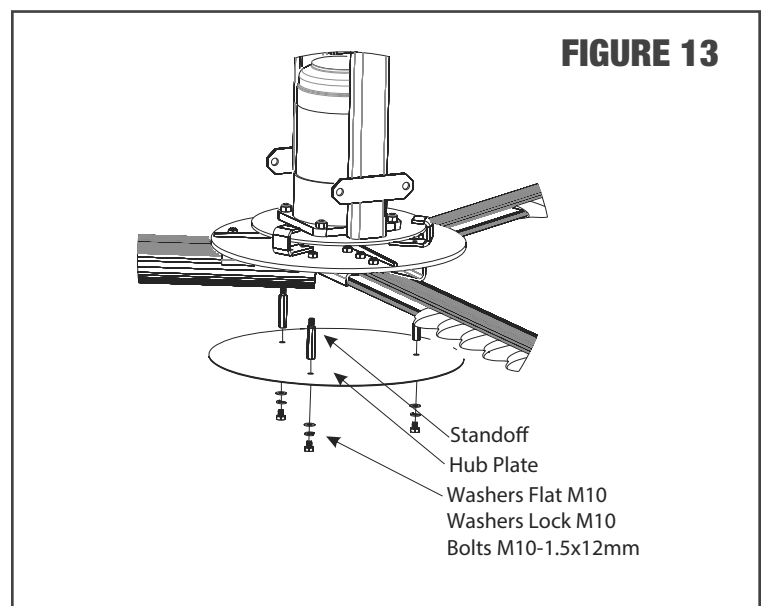

FINAL STEPS

IMPORTANT LEVELLING INSTRUCTIONS:

After your fan is installed, check the level again by placing your level vertically on the side of the fan frame. If adjustment is needed slightly tighten the guy wire on the appropriate side.

Once levelled your fan is installed and ready for electrical installation / connection.

For proper electrical connection, please consult the motor wiring diagram (supplied with the motor).

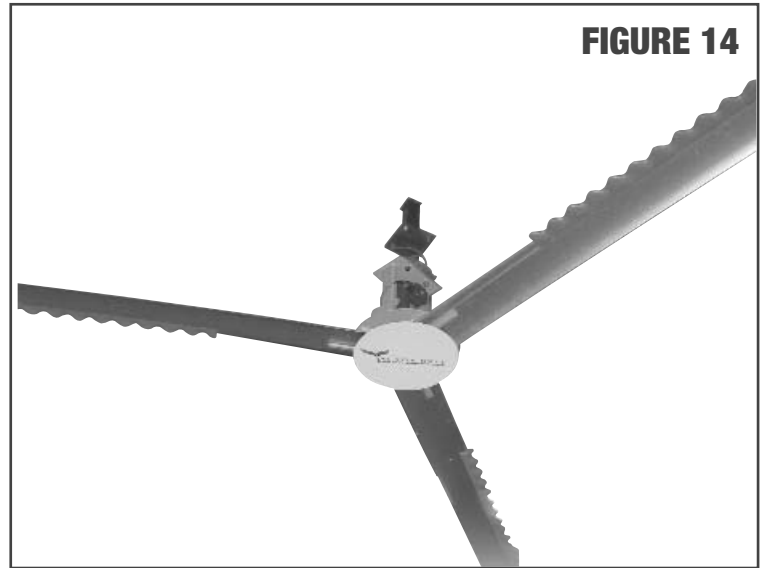

ITEMIZED CHECKLIST

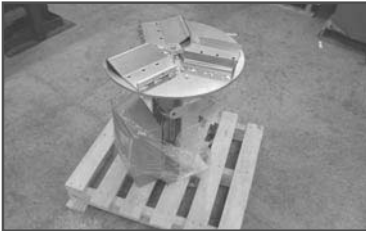

AND

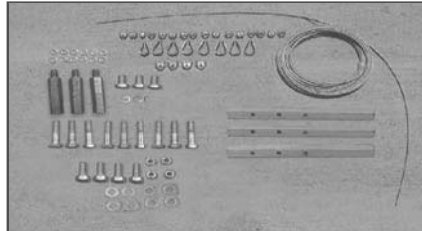

WP Fan Package
16', 24'

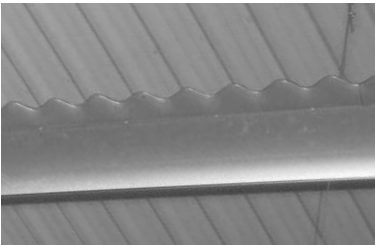

WP Blade Set
16', 24'

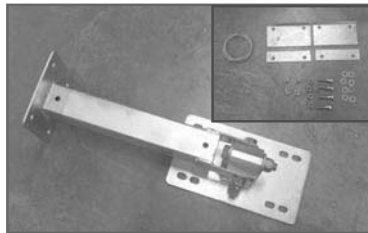

Packaged UMH Mount
1', 2', 4'



Fan Control AC Tech VFD
ESV751N02YXB (NEMA1) 230V, 1/3PH INPUT
ESV751N04TXB (NEMA1) 460V, 3PH INPUT

HVLS-ESV751N02YXC (NEMA4) 230V, 1/3PH INPUT
HVLS-ESV751N04TXC (NEMA4) 460V, 3PH INPUT

OPTIONAL COMPONENT

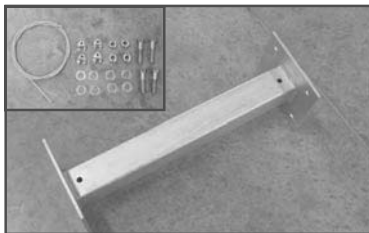

Packaged Extension Mount
2', 4'
HVLS-MBX2, HVLS-MBX4

RECOMMENDED MAINTENANCE SCHEDULE

1. No maintenance shall be done on the fan, mount or guy wires while it is in operation or powered.
2. No maintenance shall be done on the fan controller while powered unless the task involves reprogramming or troubleshooting the electrical system.
3. No maintenance shall be done within a 20' horizontal radius of the fan and 4' below and none above the blade level while it is in operation.
4. While doing maintenance on the fan, mount, or guy wires, a safety barrier shall be erected at a radius of 20' of the centre of the fan.
5. The fan controller must be locked out while maintenance is ongoing on the fan, mount, or guy wires.
6. All personnel working on the fan, mount, or guy wires, shall wear the appropriate personal safety equipment as mandated by local, provincial, and national regulations.
7. A risk assessment shall be performed before any maintenance is done on the fan, mount, guy wires and fan controller.
8. A tailboard meeting shall be performed before any work is done. A checklist shall be completed and shall include any emergency contacts for the area.

POWER UNIT

Motor

Our motor or gear motor manufacturers supply Canarm with gear motors built for our application.

Designed for use with variable frequency drives.

Maintenance Schedule

Initial Six Months

- Check for hot spots
- Re-tighten all loose electrical connections

Repeat every eighteen months thereafter

Gear Motor

Maintenance Schedule

Initial Eighteen Months

- Check oil level

Every three years thereafter

- Replace oil with recommended equivalent as specified on gear motor (acceptable fill level is within 10mm - 12mm or closer to the fill level plug).

Blades

The airfoil blades are designed for maximum efficiency and quietness with a minimum air disruption directly below the fan. All our blade shapes are extruded from aluminum alloy and heat-treated to T-6 condition. They are anodized to .0004 10 Microns clear for corrosion resistance and ease of cleaning. The blades have a one year warranty.

Maintenance Schedule

Initial Six Months

- Ensure blades are intact, level and clean as required

Every eighteen to thirty-six months thereafter

Drop/Mounting

The drop and mounting system is designed to prevent vibration or horizontal movement from being transferred back into the building structure. The system is easily installed in almost any building and allows fans to hang level from beams.

Maintenance Schedule

Initial Six Months

- Physical check of fan guy wires, re-tightening of clamps if required
- Check all nuts/bolts/clamps (missing/loose/damaged)
- Physical check of safety cable, re-tightening of clamps if required

Repeat every eighteen months thereafter

RECOMMENDED MAINTENANCE SCHEDULE CONTINUED

Control Panel

Tri-Lite HVLS controls are variable frequency drives which provide soft start/stop, variable speed control and overload protection for the motors. The VFD also allows fan control to be automated and/or integrated with other systems. The controls come with a one year limited warranty.

Maintenance Schedule

Initial Twelve Months

- Check for loose/discooured wires
- Check for hot spots
- Re-tighten all loose electrical connections

Repeat every eighteen months thereafter

Note: Maintenance schedule is based on running 5,000 hrs / year and is a guide line to ensure safe and continuous operation of the fan(s). In case of extreme operating (e.g. high humidity, aggressive environment or large temperature variations), shorter intervals between service is recommended.

SAFETY PRECAUTIONS

1. Safety cable installed as per Figure 5 .
2. Guy wire installed as per Figure 3, Figure 8, Figure 9, Figure 10 and Figure 11 in this Installation Manual.
3. Blade plates installed as per Figure 12 in this Installation Manual.
4. See below for required clearances.
5. If installed in storage facility between racks, signs must be installed identifying fan locations.
6. The variable frequency drive has several safety devices such as current limit, motor overload, minimum and maximum speed control. The controller also features a Stop button for emergency stoppage.

TRI-LITE HVLS FAN CLEARANCE REQUIREMENTS

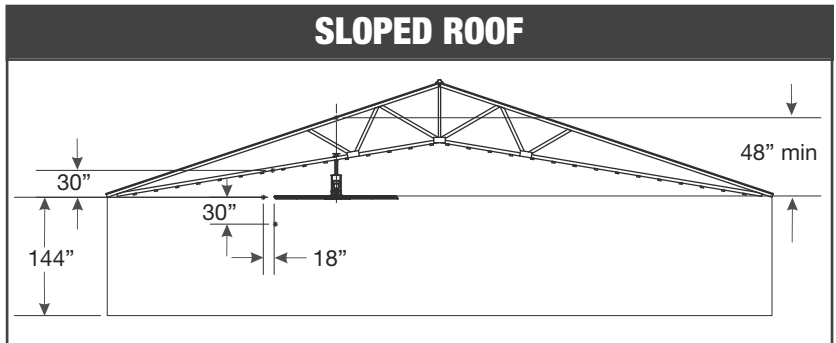
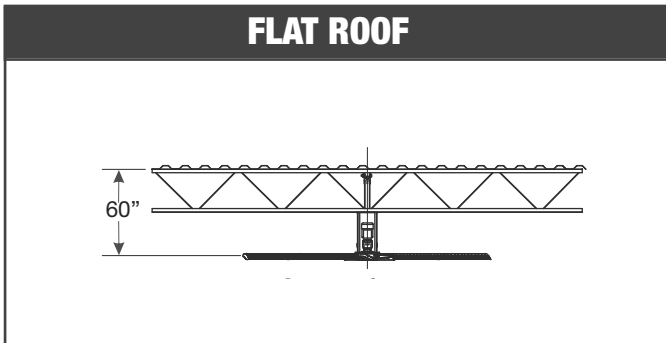
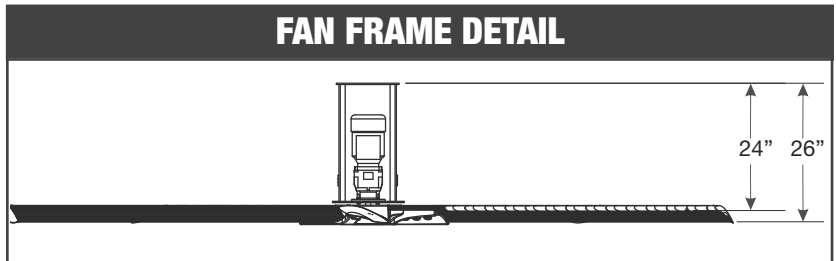

CLEARANCES

- Min 60" center of fan to roof deck for ideal operating performance without compromising overall fan performance.
- Min 30" from fan blade's leading edge to obstruction above or below fan
- Min 18" from side of fan to any obstruction
- Min 144" from floor to fan leading edge height

Contractor is responsible for verifying all site conditions to include field dimensions where applicable. If the contractor elects to make any changes without notifying Canarm Ltd., the contractor is responsible for the same. All drawings are to be used as general architectural intent unless otherwise stamped. See Engineer drawings for structural design information. Contractor to ensure that all building departments and authorities are informed in regard to the work and that all permits are attained before commencing work.

RECOMMENDED MAINTENANCE CHECKLIST

Fan Size: _____

Serial #: _____

Location: _____

Fan Size: _____

Serial #: _____

Location: _____

Fan Size: _____

Serial #: _____

Location: _____

Date	Initials

Date	Initials

Date	Initials

LIMITATION OF WARRANTY AND LIABILITY

The Tri-Lite HVLS fans are of industrial grade construction and should provide many years of virtually maintenance free use. Warranty duration is as follows:

a)	Air Foil Shaped Blade	1 year limited warranty
b)	Aluminum Alloy Hub	1 year limited warranty
c)	Gear Motor	1 year limited warranty
d)	VFD Control Panel	1 year limited warranty

Canarm Ltd. warrants that this product will, under normal use and service as specified by Canarm Ltd., operate properly and be free of defects in materials and workmanship for a period of one year from the date of purchase by customer. The term “operate properly” in this context applies to mechanical, electrical and structural functions only. No guarantee, unless and except by separate written agreement, is made regarding dimensions of air movement generated or the effectiveness of this product for its intended purpose.

Warranty Exclusions

Please note that the following may or could void any or all of the above listed warranties.

- Not following required installation procedures as in installation guide and all other documentation supplied with the fans and related equipment supplied by manufacturers of individual fan and control components.
- Not following all relevant codes and ordinances, not limited to National Electrical Code, provincial or state and local building codes.
- Not following electrical engineering industry standards regarding approved method of installing solid-state electrical equipment having characteristics of fans and all components included in this product.
- Any modification to installation, product, controls without written authorization from Canarm Ltd., even if attempting to diagnose and /or repair a problem.
- Misuse, abuse, accidents, unreasonable use or Acts of God.
- Incorrect electrical current, voltage or supply.
- Running fans at higher than recommended speeds.
- Re-setting parameters of any control without prior approval from Canarm Ltd.
- Failure to use all installation and mounting hardware supplied by Canarm Ltd.
- Failure to perform periodic maintenance as detailed in this installation manual.

LIMITATION OF WARRANTY AND LIABILITY

Canarm Ltd. reserves the right to make the final determination, based on its own evaluation of the components as to whether:

- The problem in question is the result of a defect in design, workmanship or materials and not the result of error, misuse or abuse on the part of the customer as stated above.
- Whether the problem or defect is material and requires action under this warranty.
- Whether the remedy of repair or replacement is appropriate.

Canarm Ltd. will not be responsible for remedial work necessary to correct installation procedures that do not conform to those established by the instructions, codes and standards, regardless of when the installation occurred.

With regard to electrical and electronic components provided by Canarm Ltd. that comprise part of the products, including motors, motor drives and variable frequency drives, Canarm Ltd. relies on the determination by the original manufacturer as to whether the failure of such component was the result a defect. If the manufacturer of such component determines that there was no defect and therefore refuses to cover it under warranty, Canarm Ltd. likewise will not warranty such item unless Canarm Ltd. determines that the failure of such electrical or electronic component was the result of a defect of design, workmanship or material within some other part of the products.

Warranty Duration

With respect to replacement or repair rendered, Canarm Ltd. warrants that the parts replaced or repaired will operate properly and be free from defects in materials and workmanship for a period of 90 days from the shipment date of the replacement products to the customer or for the remainder of the original warranty period, whichever is longer.

Warranty Claim Instructions

1. Contact your original dealer / salesman of the purchase when you first notice problem with the product.
2. It will be the responsibility of the dealer or salesman to assist the customer in determining what product is causing the problem.
3. If they cannot diagnose the problem, they are to contact Canarm Ltd. with all the necessary information.
4. The appropriate department will then be in contact with the customer to determine the cause of the problem.
5. Once diagnosed, submit a Purchase Order for a replacement unit complete with price.
6. A replacement unit will be shipped out upon receipt of the PO. This PO allows for an order to be established in the Canarm Ltd. System.
7. Once the units have been changed over, submit all reasonable costs to Canarm Ltd. for payment.
8. No credits or cheques will be issued until all original products are received back at Canarm Ltd. or unless Canarm Ltd. directs otherwise.

INSTALLATION OR PRODUCT PROBLEMS?

Do not return to store of purchase.

Contact **Canarm Service** at **1-800-265-1833 (CANADA)**, **1-800-267-4427 (U.S.A.)**, **1-800-567-2513 (EN FRANCAIS)**
 Monday to Friday 8:00 - 5:00pm e.s.t. or visit www.canarm.com



Canarm Ltd. - Corporate Head Office 2157 Parkedale Avenue, PO Box 367 Brockville, Ontario Canada K6V 5V6
 Tel: (613) 342-5424; Fax: (613) 342-8437
hvacsales@canarm.ca
www.canarm.com