



TWIN UNIT AVAILABLE

NEW

IDL-2 Twin Units Available
Call for pricing & availability.

IDL SERIES

Indoor Applications, Non-Insulated



IDL 07/09/10
DROP DOWN PANEL
FOR EASY ACCESS.



AVAILABLE WITH MOTORS & DRIVES FACTORY INSTALLED. CONSULT OUR DELAIR FAN SELECTION SOFTWARE FOR DETAILS.

IDL SERIES LOW PROFILE INLINE DUCT BLOWERS

Forward Curved Low Profile Inline Duct Blowers

- Use as part of an HVAC system.
- Durable galvanized, steel construction.
- Delhi forward curved blowers will not “surge”, “hunt” or “stall”.
- Ideal for indoor applications.
- Optional variable pitch motor pulley permits field adjustment (typically + or - 15%) to match air delivery needs.
- Quiet forward curved blowers typically operate at ½ the rpm of other inline solutions.
- Low profile design for use in bulkheads or other areas with reduced clearance.
- Easy to use drop down access panel provides quick access to blower and motor.

INDUSTRIES SERVED

- Commercial HVAC
- Ventilation
- Heating
- Cooling
- Construction

PERFORMANCE SPECIFICATIONS

MODEL	TYPICAL MAXIMUM CFM @ SP						Min HP	Max HP
	1/2" SP	1" SP	1 1/2" SP	2" SP	2 1/2" SP			
IDL07	1400	1250	1100	900	700	1/6	3/4	
IDL09	1800	1600	1400	1100	800	1/6	3/4	
IDL10	2100	1800	1400	1000	700	1/6	1 1/2	
IDL12	3600	3200	2800	2300	1800	1/3	1 1/2	
IDL15	5700	5200	4600	4000	3400	1/3	3	

CFM values listed right are summarized for convenience. For full performance data refer to our Delair program.

Power rating (BHP) does not include transmission losses. Performance certified is for installation type B: Free inlet, Ducted outlet. Performance ratings do not include the effect of appurtenances (accessories).

*CONSULT OUR DELAIR SOFTWARE FOR FAN CURVES & PERFORMANCE DATA. DOWNLOAD DELAIR @ WWW.CANARM.COM/DELAIR

FEATURES

- **Wheel Diameters:** 7" through 15"
- **CFM:** Approximately 500 to 5700 CFM in a single blower.
- Constructed from galvanized steel for durability.
- Forward Curved blowers operate at low RPM for low noise levels.
- Heavy duty ball bearings suitable for -65° F to +250° F.
- Keywayed shafts both ends for clockwise or counter clockwise rotation.
- Saddle type motor mounting platform provides extended belt tension adjustment range on all IDL models.

TYPICAL APPLICATIONS FOR OUR INLINE BLOWERS

- An Inline make-up air solution for cases where a rooftop curb mounted solution is not available.
- As an air moving module for systems built up with other components such as heating/cooling coils.
- Noise sensitive areas - the low rpm forward curved wheel typically radiates less vibration than higher rpm backward inclined wheel solutions.
- When the application requires an air mover in a duct system located in a ceiling space.
- Redistribution or recirculation of air in a work space.
- Interlocked with entry doors to prevent entry of cold outdoor air into retail sales space and thus greets customers with warmth.
- Bathroom/rest room exhaust - one duct blower serving multiple intakes.
- Ideal for use in bulkheads and other areas with low clearance.



FORWARD CURVED BLOWERS OPERATE AT LOW RPM FOR LOW NOISE

IDL SERIES

Forward Curved Low Profile Inline Duct Blowers

DIMENSIONS

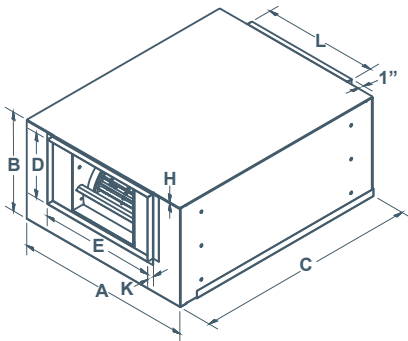

MODEL	A	B	C	OUTLET				INLET		SHAFT DIAMETER	UNIT WEIGHT (LBS) (without motor)
				D	E	H	K	L	M		
IDL07	23"	13"	29"	8 1/2"	15"	1/8"	1"	15"	8 1/2"	3/4"	TBA
IDL09	26"	16"	32"	10 1/2"	18"	1/8"	1"	18"	10 1/2"	3/4"	TBA
IDL10	32"	19"	36"	12"	24"	1/2"	1"	24"	12"	3/4"	TBA
IDL12	36"	21 5/8"	42"	13 7/8"	28"	1/2"	1"	28"	13 7/8"	3/4"	TBA
IDL15	42"	25"	46"	16 1/2"	32"	1/2"	1"	32"	16 1/2"	1"	TBA

IDL12/15

- IDL12/15 - Motor is attached to cabinet
- Ample space within to facilitate work inside the unit



ACCESSORIES

- Filter sections
- External Vibration Isolators
- Disconnect Switch
- Side Access Door

FILTER SECTIONS & INTAKE HOODS

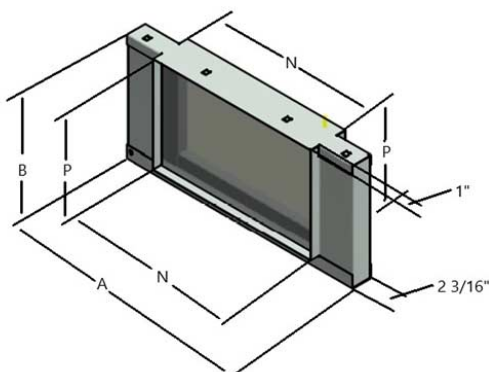

FIDL FILTER SECTION For IDL Series Blowers

MODEL	A	B	N	P	FILTER		UNIT WEIGHT (LBS)
					SIZE	QTY	
FIDL07	24 1/4"	10"	15 1/4"	8 5/8"	10" X 20" X 1"	1	8
FIDL09	25 3/4"	12 3/16"	18 1/8"	10 15/16"	12" X 24" X 1"	1	9
FIDL10	26 3/16"	15 7/8"	24"	11 7/8"	16" X 24" X 1"	1	11
FIDL12	30 3/16"	20 1/16"	28"	14"	20" X 28-1/2" X 1"	1	13
FIDL15	34"	18"	32 1/4"	16 3/4"	17" X 33" X 1"	1	18