



# INSTALLATION, OPERATION, AND MAINTENANCE MANUAL

## TUBE AXIAL FANS

### BTA, WTA, HTA, DDA

The purpose of this manual is to aid in the proper installation and operation of the fans. These instructions are intended to supplement good general practices and are not intended to cover detailed instruction procedures. It is the responsibility of the purchaser to assure that the installation and maintenance of this equipment is handled by qualified personnel.

Inspect all shipments carefully for damage. **THE RECEIVER MUST NOTE ANY DAMAGE ON THE CARRIER'S BILL OF LADING AND FILE A CLAIM IMMEDIATELY WITH THE FREIGHT COMPANY.**

## INSTALLATION

1. The fans, when lifted, should be lifted using the flanged ends of the tube or by placing a sling around the fan tube, and never by the motor, belt tube or motor base.
2. Caution: The fan contains rotating parts and requires electrical service. Appropriate safety precautions should be taken during installation, operation and maintenance.
3. All electrical work must be done, in accordance with all applicable electrical codes, by a qualified electrician.
4. Prior to wiring, ensure that the power supply is locked in the **OFF** position and that the motor nameplate voltage and the supply voltage match.
5. Be sure to keep all electrical wiring clear of any moving parts.
6. Tighten all nuts, bolts and setscrews to the proper torque settings (see chart), as some may have loosened during shipping.
7. Before starting the fan, ensure that the wheel rotates freely.
8. On belt driven fans, assure that the belts are aligned and tensioned correctly.
9. Assure that all protective guards and other safety devices are installed properly prior to fan start-up.

10. When hanging tube axial fans, the installer must provide suitable rods and hanging vibration isolators (both vertical and horizontal applications). Do not support the ductwork, etc., from the fan. The fan should be supported independently using isolators designed to support the weight of the fan only.
11. The tube axial fans are suitable for installation either vertically or horizontally however you must specify and order either the vertical or horizontal support clips (optional) when you place your fan order.

### **Wiring Instructions**

A qualified electrician in accordance with all local and National Electrical Codes should do all wiring. **Lock off all power sources before any wiring is to be performed.** Leave enough slack in the wiring to allow for motor movement when adjusting the belt tension. Excess wire must be restrained in order to prevent it from entanglement with moving parts. Disconnect switches are recommended and should be located near the fan in order to, swiftly cut off power in case of an emergency and maintain complete control of the power source. Some motors may have to be removed in order to make the connections in the motor terminal box. Follow the wiring diagrams on the motor nameplate.

1. Belt Driven Fans
  - Extend the proper gauge wire to the fan motor
  - Restrain excess wire from entanglement with moving parts.
  - Wire using the wiring diagram on the motor name plate
2. Direct Drive Fans
  - Extend the proper gauge wire to the junction box
  - Wire the motor using the motor wiring diagram

### **Floor Mounted Fans**

If the fan is to be floor mounted it should be mounted using vibration isolators to reduce vibration and noise. The recommended type is rubber in shear isolators.

- Level the mounting surface
- Raise the fan up to provide the necessary room to mount the isolators between the fan and the mounting surface.
- Use spacers to support the fan in this position
- Place the isolators under the fan and fasten them to the fan with bolts
- Remove the spacers and let the fan sit on the floor
- Fasten isolators to mounting surface
- Attach the duct to it's flanges
- Drill holes in the duct flanges to match the fan flanges and bolt together using a flexible connector.

## Suspended Fans

This is the most common method of installation. Fans mounted in ductwork are usually suspended from the ceiling using threaded rod and either spring or rubber in shear ceiling isolators.

- Attach threaded rod to the support structure directly over the fan mounting holes.
- Raise the fan up to the installation location and temporarily support it in place.
- Attach the isolators to the ends of the threaded rod
- Attach the other end of the isolator brackets to the support clips (vertical or horizontal)
- Using an adjusting nut, on the threaded rod, adjust until all the isolators bear the weight uniformly.
- Secure firmly using a locking nut
- Remove the temporary fan supports
- Attach the duct to it's flanges
- Drill holes in the duct flanges to match the fan flanges and bolt together (use flexible connection to connect fan to ductwork). **NOTE:** never support the ductwork from the fan as the isolators have been sized to support the fan weight only.

## Typical Installations

Refer to page 9-10

## OPERATION

### Pre Start Inspection

- Lock out all power sources
- Inspect all fasteners and set screws and tighten as required to the proper torque settings (see chart)
- Inspect belt alignment and tension
- Confirm power source voltage and motor voltage are the same and that the motor is wired correctly
- Rotate the fan blade to ensure that neither the fan blade nor the belts come into contact with the housing
- Inspect the fan and the ductwork to ensure they are free of debris
- Check to ensure that all guards and accessories are securely mounted
- Check to be sure the propeller rotation is correct

## Start Up

Restore power to the fan, turn it on and check for the following.

- Correct rotation
- Improper amperage
- Excess vibration
- Unusual noise
- Incorrect belt tension or alignment

If a problem is discovered shut off the fan and refer to the section on troubleshooting to discover the cause of the problem. The fan should be inspected after 30 minutes, 8 hours and 24 hours of operation to ensure all fasteners are tight and belts are properly tensioned and aligned.

## MAINTENANCE

### WARNING

---

Disconnect and secure to the **OFF** position all electrical power to the fan prior to inspection or servicing. Failure to comply with this safety precaution could result in serious injury or death.

---

1. Fans should be checked at least once a year. For critical or severe applications, a routine check every two or three months is suggested.
2. When removing or installing a belt, do not force the belt over the sheave; loosen the motor mount so that the belt can be easily slipped over the sheave.
3. The belt on belt driven units should be removed and carefully checked for cracks, ply separation and irregular wear. A small irregularity in the contact surface of the belt will result in noisy operation. If any of these defects are apparent, the belt should be replaced. At the same time, check the sheaves for chips, dents or rough surfaces that could damage the belt.
4. The correct belt tension is important. Too tight a belt will result in excess bearing pressure, which can cause premature bearing failure and may cause the motor to overload; too loose a belt will result in slippage, which will burn out belts. Proper belt deflection should be 1/64" (half way between sheave centers) for each inch of belt span when a force of approximately five lbs. is applied.
5. The belt alignment should be checked to be sure that the belt is running perpendicular to the rotating shaft. The motor and drive shafts must be parallel.
6. A periodic inspection of all fasteners should be carried out to ensure they have not loosened due to vibration. Particular attention should be paid to fasteners attaching the wheel to the shaft and those attaching the shaft to the bearings.

7. The standard pillow blocks on belt driven fans are factory lubricated. These bearings should be lubricated on a semi- annual basis (more frequently in severe applications) using a high quality lithium based grease. With the unit running add grease very slowly, using a manual grease gun, until a slight bead of grease forms at the seal. Be careful not to unseat the seal by over lubricating or by using excessive pressure. When the bearings are obstructed from view use no more than three injections with a hand operated grease gun
8. Dust and dirt on the exterior surface of the motor, fan tube and the entire fan wheel should be removed at intervals determined by the severity of the application, to ensure proper service life and safety.

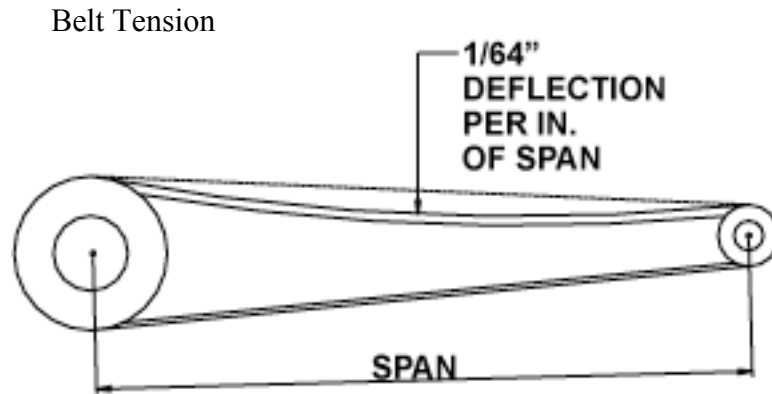

### **Pulley and Belt Replacement**

In the course of regular maintenance the belts and pulleys may have to be changed and or adjusted. The recommended procedure is as follows:

- Do not change the pulley pitch diameter in order to tension the belts. This will result in a change in the fan speed.
- Loosen the nuts on the motor plate or motor in order to reduce the belt tension such that the belts will easily slip over the pulleys. Never force the belts over the rim of the pulley.
- Loosen the setscrews on the pulleys and remove from either the motor or fan shaft using a two or three jaw puller.
- Remove any shaft imperfection such as setscrew mark using a file or emery cloth.
- Install the replacement pulleys tightening all setscrews to the recommended torque rating (see chart) and ensuring that they are properly aligned.
- Pulley alignment is achieved by moving the pulleys on their respective shafts or moving the entire motor until the pulleys are correctly aligned (see figure). Using a square with one edge parallel to the motor shaft adjust the pulleys until the other edge is parallel to the belts.
- Slip the belts over the pulleys then adjust the motor/ motor plate until the proper tension is reached (1/64" deflection, half way between pulley centers, per inch of belt span when pressed firmly).
- Tighten the motor plate/ motor adjusting nuts in place

### Pulley Alignment

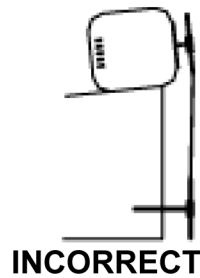
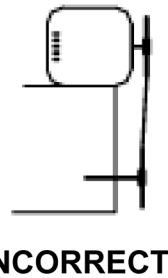
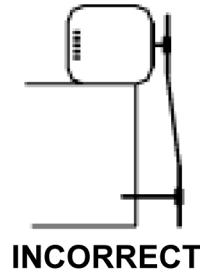
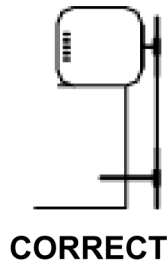

### Recommended Torque for Setscrews/Bolts (inch/lbs)

SETSCREWS				HOLD DOWN BOLTS	
SIZE	HEX KEY	RECOMMENDED TORQUE INCH-LBS		SIZE	TORQUE INCH-LBS
		MIN	MAX		
NO.10	3/32"	28	33	3/8"-16	240
1/4"	1/8"	66	80	1/2"-13	600
5/16"	5/32"	126	156	5/8"-11	1200
3/8"	3/16"	228	275	3/4 "-10	2100
7/16"	7/32"	348	384	7/8"-9	2040
1/2"	1/4"	504	600	1"-8	3000
5/8"	5/16"	1104	1200	1-1/8"-7	4200
3/4"	3/8"	1440	1800	1-1/4"-7	6000

### Bearings Replacement

Canarm/LFI uses pillow block bearings.

- Remove the bearing cover
- Before removing the bearings mark the positions of the fan blade, bearings and pulley on the shaft.
- Note the clearance between the fan blade and the venturi.
- Remove the pulley and fan blade from the shaft using a puller.
- Unbolt the bearings and remove the shaft and pillow blocks as one unit.
- Clean the shaft and remove any marks using a file or emery cloth then remove the bearings using a bearing puller.
- Inspect the shaft and replace if necessary.
- Mount the new bearings on a section of the shaft that is not worn by tapping the bearings inner ring face using a soft mallet.
- Align the setscrews on the bearings and then tighten one setscrew on each bearing.
- Loosely install the bearings on the bearing mount.

- Rotate the shaft to find the center of free movement.
  - Install the propeller adjusting the bearing location to center the blade in the venturi.
  - Tighten the bearing bolts to the proper torque rating (see chart)
  - Turn the propeller by hand the propeller should rotate freely with the same resistance as before the bearing bolts were tightened.
  - Tighten all setscrews to the proper torque rating (see chart)
  - Install pulley and adjust belt tension.
- Follow the start up steps as outlined above

## PARTS LIST

MODELS: BTA, WTA, HTA

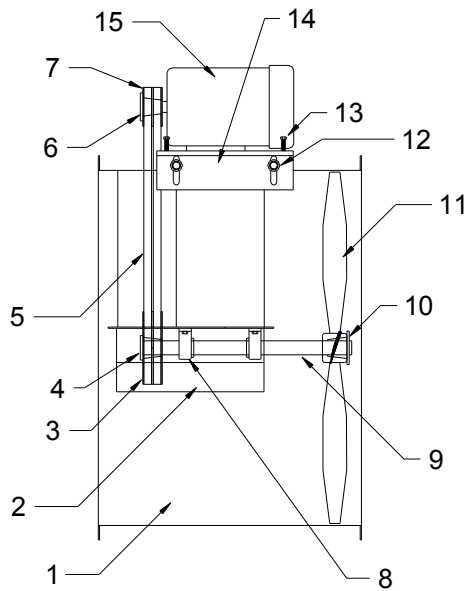

ITEM	DESCRIPTION	QUANTITY
1	FAN HOUSING	1
2	BEARING & SHAFT COVER	1
3	DRIVEN SHEAVE	1
4	DRIVEN SHEAVE BUSHING	1
5	V-BELTS	2
6	MOTOR SHEAVE BUSHING	1
7	MOTOR SHEAVE	1
8	PILLOW BLOCK BEARINGS	2
9	FAN SHAFT	1
10	FAN BUSHING	1
11	FAN PROP.	1
12	BASE LOCKING BOLTS	4
13	MOTOR BASE ADJ. BOLTS	4
14	MOTOR BASE	1
15	MOTOR	1

## PARTS LIST

MODEL: DDA

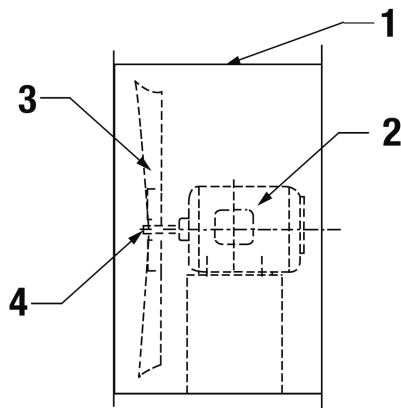

ITEM	DESCRIPTION	QUANTITY
1	FAN HOUSING	1
2	MOTOR	1
3	FAN PROP	1
4	FAN BUSHING	1

## FAN TROUBLE SHOOTING GUIDE

### PROBLEM

### POSSIBLE CAUSES

#### VIBRATION

Impeller or sheaves loose  
Belts not tensioned properly  
Bent shaft  
Out of balance impeller  
Loose fasteners  
Loose or worn bearings  
Drive misalignment  
Fan not properly installed  
Mismatched belts  
Out of balance sheaves  
Improper fan installation

#### MOTOR OVERLOADING

Static pressure higher than design  
Impeller rotating in the wrong direction  
Improper fan speed  
Defective motor  
Fan speed higher than design

#### TOO MUCH AIR

Filters missing  
Static pressure lower than design  
Fan speed higher than design

#### FAN DOES NOT OPERATE

Lack of electricity to the fan  
Fan wired improperly  
Broken or missing belt  
Missing or blown fuses  
Overload protection has broken circuit  
Defective motor

#### EXCESSIVE NOISE

Impeller or sheaves loose  
Belts not properly tensioned  
Sheaves not properly aligned  
Impeller out of balance  
Sheaves out of balance  
Bent shaft  
Bearings defective or need lubrication  
Worn belts  
Vibration or lack of isolation  
Loose fasteners  
High velocity air



# Typical Installations

## Ducted Installations

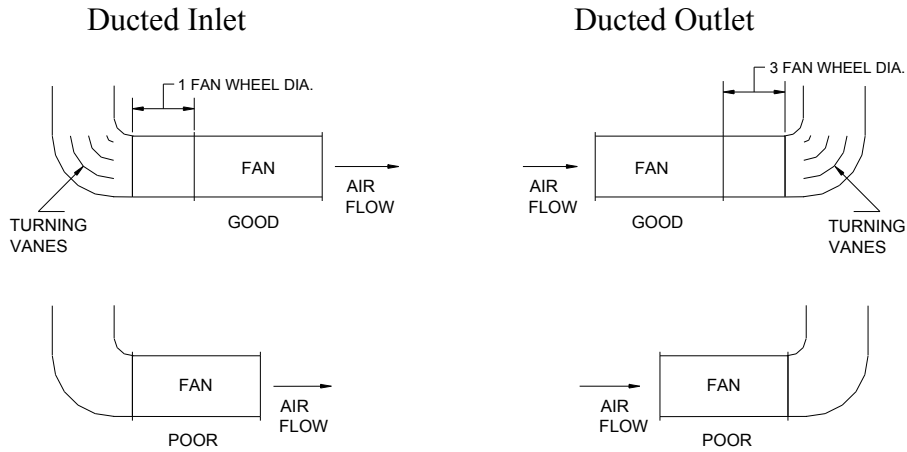

### Ducted Inlets

When a duct elbow is located too close to the fan inlet it reduces the fan performance due to uneven air supply to the fan wheel. A minimum of one fan wheel diameter of straight duct prior to entering the fan will allow the fan to achieve full performance.

### Ducted Outlets

When a duct elbow is located too close to the fan discharge fan performance is reduced. There should be a minimum of three fan wheel diameters of straight duct, prior to any elbows, off the discharge of the fan in order to achieve proper fan performance.

### Suspended Vertically (complete with optional vertical support clips)

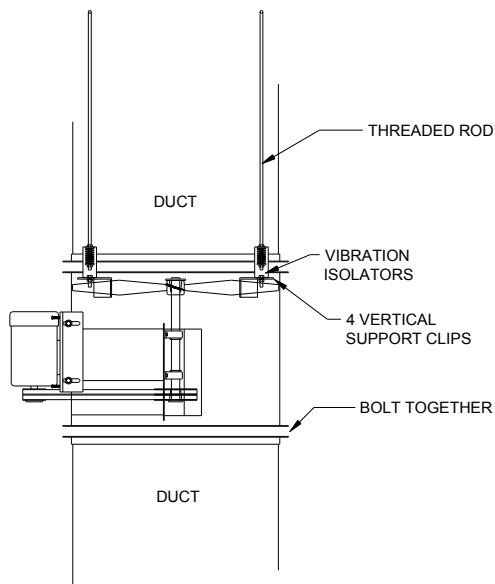

Suspended Horizontally  
(complete with optional horizontal support clips)

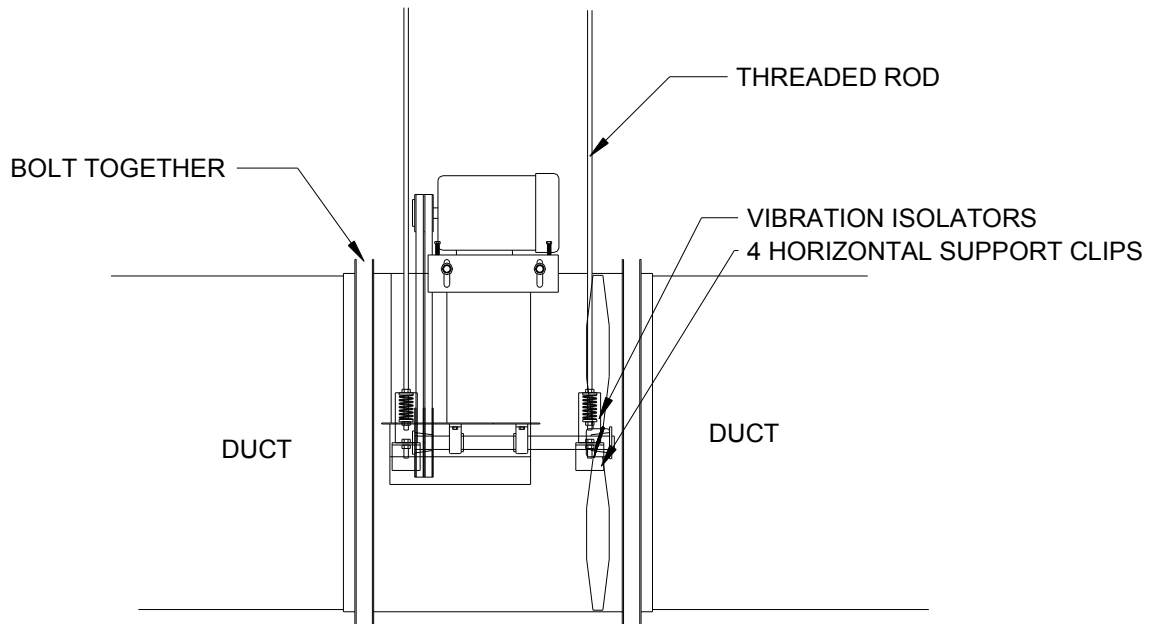

Floor Mounted  
(complete with optional support legs)

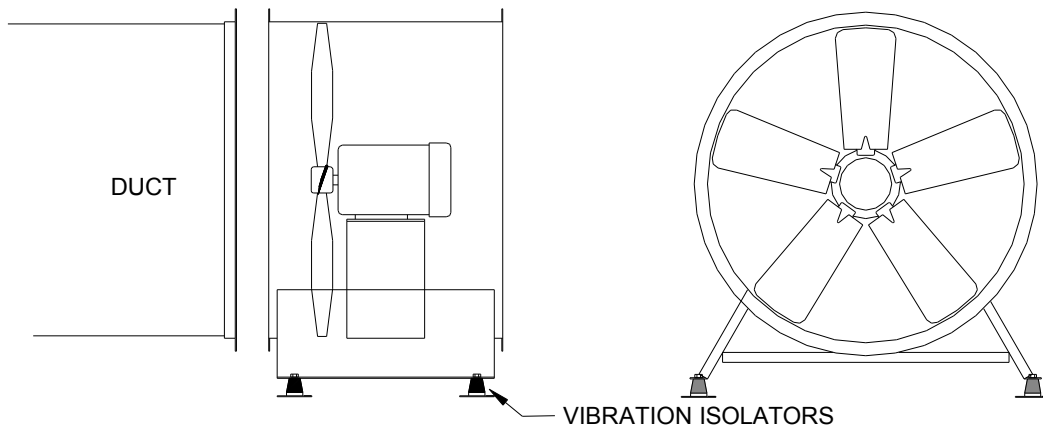

## WARRANTY

Canarm/LFI Limited warrants this equipment to be free from defects in material and workmanship for a period of one year from the date of sale. The motor manufacturer warrants motors for a period of one year. Should motors, supplied by Canarm/LFI Limited, prove to be defective during the warranty period they should be returned to the nearest authorized motor manufacturer's warranty depot.

Any fans or parts, which prove to be defective during the warranty period, will be repaired or replaced at our option when returned to our factory, transportation prepaid. A return authorization number that is to be obtained from their customer service department must accompany all returns to Canarm/LFI Limited.

Canarm/LFI Limited will not be responsible for any removal or installation costs.



### **CANARM LTD.**

2157 Parkedale Avenue, PO Box 367, Brockville, Ontario K6V 5V6 Canada

Ph: (613) 342-5424

Fax: (613) 342-8437

[www.canarm.com](http://www.canarm.com)

July 2003