

# BELT DRIVE TUBE AXIAL DUCT FANS

Designed for duct connected applications such as paint booth exhaust, air make-up fans, general exhaust, etc.



Paint color on HTA models is beige.

- BTA** - For clean, dry air with a maximum temperature of 200°F (95°C)
- WTA** - For moisture laden air with a maximum temperature of 200°F (95°C)
- HTA** - For clean, dry air with a maximum temperature of 375°F (190°C)

To order WTA or HTA models, replace “BTA” with “WTA” or “HTA” in the specifications table.

## FEATURES

### BTA

- Adjustable motor base.
- Heavy duty pillow block ball bearings with high temperature grease.
- Extended lube lines with external grease fittings.
- TEFC motors are standard.
- Cast aluminum blades up to 48”; fans 54” & 60” have polypropylene reinforced fiberglass blades.
- Airfoil shaped belt tube for improved efficiency; motor, belts, drives and bearings are isolated from air stream.

### WTA

- Heavy duty pillow block bearings with moisture displacement collars + stainless steel shaft.

### HTA

- Paint color is beige on these models, high temperature bearings and grease.

Non-stock, made-to-order products are non-returnable and cannot be cancelled.

## OPTIONS & ACCESSORIES

For a complete listing of all available options and accessories available for this fan and ordering guidelines, see Tube Axial Duct Fan Options & Accessories page.

When ordering, replace “T” in the model name shown in the specifications table with ALL letters of the options and accessories required, as shown on the Tube Axial Duct Fan Options page.

Options must be requested at time of order, as they cannot be added later.

## SPECIFICATION NOTES

For three phase motors, substitute “\*\*” with “M” for 230/460 volt or “P” for 575 volt. If 208V is required please specify.

+ Motor RPM is 3450. All others are 1750.

Fan tested in accordance with AMCA Standard 210 in a figure 12A configuration.

FEP for models using a single-phase motor are determined using AMCA Standard 214-21, method 6.3 using standard air density and V-belt drive.

FEP for models using a three-phase motor are determined using AMCA Standard 214-21, method 6.4 using standard air density, V-belt drive, 4 pole TEFC motors without VFD.

dBA ratings shown are measured at 0” static pressure and should be used as a guideline only.

Power rating does not include transmission losses.

Performance ratings do not include the effects of appurtenances.

Operation of the axial impeller in a configuration different from the published test configuration will affect performance.

## DIMENSIONS

FAN SIZE	A	B	C	D	E	F	WEIGHT (lbs) without motor
12”	12”	14”	15 1/8”	17”	3/4”	3/16”	53
15”	15 3/8”	17”	18 3/8”	17”	3/4”	3/16”	62
18”	18 3/8”	20”	21 3/8”	21”	1”	1/4”	76
24”	24 3/8”	25 7/8”	27 3/8”	21”	1 3/16”	1/4”	132
30”	30 3/8”	32 3/8”	33 3/8”	21”	1 7/16”	3/8”	174
34”	34 3/8”	36 3/8”	37 3/8”	27”	1 7/16”	3/8”	225
36”	36 3/8”	38 3/8”	39 3/8”	27”	1 7/16”	3/8”	239
42”	42 3/8”	44 3/8”	45 3/8”	32”	1 7/16”	3/8”	326
48”	48 3/8”	50 3/8”	51 3/8”	32”	1 15/16”	1/2”	420
54”	54 3/8”	56 3/8”	57 3/8”	40”	1 15/16”	1/2”	552
60”	60 3/8”	62 3/8”	63 3/8”	40”	1 15/16”	1/2”	601

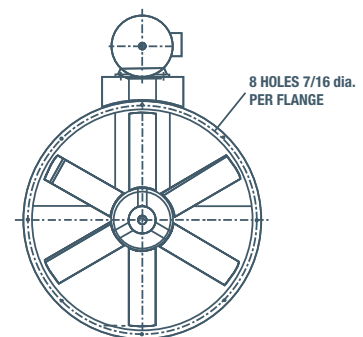
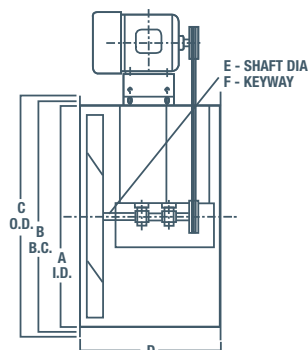



# TUBE AXIAL DUCT FAN OPTIONS & ACCESSORIES



**A**  
DISCONNECT SWITCH



**B/J**  
MC - GUARDS

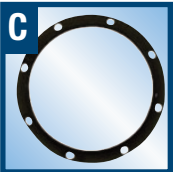

**C**  
CR - COMPANION RING



**D**  
SCV - VERTICAL SUPPORT CLIPS



**K**  
SCH - HORIZONTAL SUPPORT CLIP



**E**  
SPL - SUPPORT LEGS



**F**  
MCVR - MOTOR & BELT COVER



**G**  
BLG - BELT GUARD

REFERENCE	ITEM	DESCRIPTION	SPECIAL ORDERING GUIDELINES
A	<b>Disconnect Switch</b> (Accessory)	See page K4 in Controls & Thermostats section for more information.	Ships loose. Available as an accessory ordered separately.
B	<b>Inlet Guard</b> (Accessory)	<ul style="list-style-type: none"> <li>Spiral plated OSHA guard.</li> <li>Fits intake or exhaust.</li> </ul>	To order installed, add letter to part number. Also available as an accessory ordered separately.
J	<b>Outlet Guard</b> (Accessory)	<ul style="list-style-type: none"> <li>Can be used in conjunction with companion ring.</li> </ul>	
C	<b>Companion Rings</b> (Accessory)	<ul style="list-style-type: none"> <li>1/4" plate angle ring.</li> <li>Used to attach guards or ducts to tube axial fans.</li> </ul>	To order installed, add letter to part number. Also available as an accessory ordered separately.
D	<b>Vertical Support Clips</b> (Accessory)	<ul style="list-style-type: none"> <li>1/4" plate vertical support clips are welded onto fan.</li> <li>Four clips per end.</li> </ul>	Must be requested at time of order.
K	<b>Horizontal Support Clips</b> (Accessory)	<ul style="list-style-type: none"> <li>1/4" plate horizontal support clips.</li> <li>Bolts to the vertical support clips welded onto the fan.</li> <li>Two clips per end.</li> </ul>	Must be requested at time of order. Must be used with vertical clips (D). <b>Eg)</b> For a BTA18T10050 with horizontal clips & belt guard, use BTA18DKG10050. <b>Note:</b> "D" for vertical clips must be indicated as well as the "K" for horizontal clips.
E	<b>Support Legs</b> (Option)	<ul style="list-style-type: none"> <li>Heavy duty support legs are welded to the fan.</li> <li>Suitable for mounting tube axial to the floor.</li> <li>4" Standard. 16" available. Consult factory.</li> <li>Sold in pairs.</li> </ul>	Must be requested at time of order.
F	<b>Motor &amp; Belt Covers</b> (Accessory)	<ul style="list-style-type: none"> <li>18 gauge galvanized steel.</li> <li>Acts as both motor and belt cover.</li> <li>3/4" expanded metal screen allows motor heat to escape.</li> <li>Bolts to motor mount.</li> </ul>	For HTA/BTAWTA Fans only. To order installed, add letter to part number. Also available as an accessory ordered separately.
G	<b>Belt Guard</b> (Accessory)	<ul style="list-style-type: none"> <li>Belt and guards protect the belt and drives.</li> <li>18 gauge galvanized steel.</li> </ul>	For HTA/BTAWTA Fans only. Not required with motor cover. To order installed, add letter to part number. Also available as an accessory ordered separately.
H	<b>Inspection Door</b> (Option)	<ul style="list-style-type: none"> <li>10" x 12" inspection door.</li> <li>Hinged and bolted.</li> <li>Air dry finish.</li> <li>Can be installed in location specified by customer.</li> </ul>	Must be requested at time of order.
I	<b>Specials (not shown)</b>	Can include: <ul style="list-style-type: none"> <li>Explosion Proof Motors</li> <li>Steel Fan Blades</li> <li>Optional Coating</li> </ul>	Must be requested at time of order.
L	<b>Weather Cover</b> (Accessory)	<ul style="list-style-type: none"> <li>18 gauge galvanized steel.</li> <li>Acts as both motor and belt cover.</li> <li>Enclosed for weather protection.</li> <li>Bolts to motor mount.</li> </ul>	For HTA/BTAWTA Fans only. To order installed, add letter to part number. Also available as an accessory ordered separately.
W (Not Shown)	<b>Wired Junction Box</b> (Option)	<ul style="list-style-type: none"> <li>Wired junction box using BX cable.</li> </ul>	<ul style="list-style-type: none"> <li>For BTA models only!</li> <li>Must be requested at time of order.</li> </ul>

## ORDERING EXAMPLES:

**EX 1)** If ordering a BTA18T10050 with support legs (E) and an inspection door (H), use **BTA18EH10050**.

**EX 2)** If ordering a BTA18T10050 with horizontal clips & belt guard, use **BTA18DKG10050**.

ACCESSORIES				OPTIONS INSTALLED WELDED TO TUBE		
FAN SIZE	COMPANION RING	GUARD	HORIZONTAL CLIP	SUPPORT LEG	VERTICAL CLIP	INSPECTION DOOR
12"	CR12P	MC12G	SCH12-60 (Must order vertical clip accessory)	SPL12	SCV12-60	ID12
15"	CR15P	MC15G		SPL15		ID15
18"	CR18P	MC18G		SPL18		ID18
20"	CR20P	MC20G		SPL20		ID20
24"	CR24P	MC24G		SPL24		ID24
30"	CR30P	MC30G		SPL30		ID30
34"	CR34P	MC34G		SPL34		ID34
36"	CR36P	MC36G		SPL36		ID36
42"	CR42P	MC42G		SPL42		ID42
48"	CR48P	MC48G		SPL48		ID48
54"	CR54P	MC54G		SPL54		ID54
60"	CR60P	MC60G		SPL60		ID60

ACCESSORIES	
FRAME SIZE	BELT GUARD
48 - 145T	BLGD1
182T - 184T	BLGD2
213T - 256T	BLGD3
284 AND UP	BLGD4

ACCESSORIES		
BTA SIZE	WEATHER COVER	MOTOR COVER
12" - 18"	MCVR1-WP	MCVR1
24" - 30"	MCVR2-WP	MCVR2
34" - 36"	MCVR3-WP	MCVR3
42" - 48"	MCVR4-WP	MCVR4
54" - 60"	MCVR5-WP	MCVR5



**H**  
ID - INSPECTION DOOR



**L**  
WC - WEATHER COVER