

EC MOTORS

for energy savings



QUICK RELEASE LATCH FOR EASY MOTOR ACCESS



ALX-DD-EC SERIES DOWNBLAST DIRECT DRIVE SPUN ALUMINUM EXHAUSTERS

Ideal for exhausting air from factories, offices, warehouses or commercial buildings. The ALX series spun aluminum exhaust fan can be used as either a roof top or wall mount exhaust fan.

**FEATURING EC MOTORS
- UP TO 82% EFFICIENCY**



**ENERGY SAVINGS OF UP TO 70% OVER
REGULAR DUTY PSC MOTORS**

FEATURES

- Spun aluminum housing will not rust, chip or peel.
- Aluminum backward inclined wheel is non-overloading.
- For models with PSC Motors see ALX-DD.
- All motors are 1 Phase 120/240V operation and can be operated at 50 or 60 Hz.
- All units can be wall mounted.
- Quick release latches for easy motor access on ALX135 – ALX165.
- Comes with bird screen.

EC MOTORS

- EC motors offer true variable speed operation and up to 70% energy savings over PSC motors.
- On-board speed adjustment allows simple setup and balancing with LED display.
- Can be controlled remotely up to 50' using a remote mount potentiometer or 0-10V.

OPTIONS & ACCESSORIES

- Motorized damper
- Gravity (automatic) damper
- Wall mount bracket (for all sizes up to 24")
- Curb hinge
- Disconnect switches
- Roof Curbs
- Remote mount potentiometer
- Other base (curb cap) options available. See C2 in dimensions table.

DIMENSIONS

MODEL	DIMENSIONS (INCHES)									WEIGHT (lbs)	
	A	B	C	C2	D	E	F	G Ø	Wheel Diameter		Roof Opening
ALX105-DD-EC	18.00	25.00	19.00	21.00	2.50	1.50	3.50	0.38	10.50	15.00	33
ALX120-DD-EC	19.00	25.00	19.00	21.00	3.50	1.50	3.50	0.38	12.25	15.00	35
ALX135-DD-EC	22.25	31.25	21.00	24.75	3.13	2.00	3.75	0.44	13.50	17.00	51
ALX150-DD-EC	23.13	31.25	21.00	24.75	3.75	2.00	3.75	0.44	15.00	17.00	56
ALX165-DD-EC	27.13	36.25	24.75	28.00	5.00	2.00	4.00	0.44	16.50	20.75	100
ALX180-DD-EC	31.75	36.25	28.00	24.75	5.50	2.00	4.00	0.44	18.25	20.75	114
ALX210-DD-EC	36.25	43.75	33.13	40.00	5.25	2.50	4.00	0.44	21.00	29.00	176

ALX105 / 120 - DD

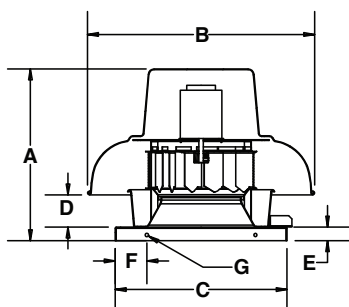

ALX135 / 150 / 165 / 180 - DD

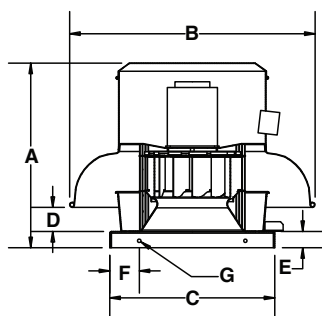

Canarm certifies that the ALX-DD-EC Series shown herein are licensed to bear the AMCA Seal. The ratings shown are based on tests and procedures performed in accordance with AMCA Publications 211 & 311 and comply with the requirements of the AMCA Certified Ratings Programme.

The AMCA certified ratings seal applies to air and sound performance only. The ALX-DD-EC Series shown herein are not approved by AMCA for FEI ratings.





ALX-DD-EC SERIES - DOWNBLAST DIRECT DRIVE SPUN ALUMINUM EXHAUSTERS

PERFORMANCE SPECIFICATIONS & CFM RATINGS

Model	Motor			Airflow (CFM) @ Static Pressure															
	HP	Variable Speed	Max RPM	0.0"		.25"		.5"		.75"		1.00"		1.25"		1.5"		1.75"	
				High	Low	High	Low	High	Low	High	Low	High	Low	High	Low	High	Low	High	Low
ALX105-DD033EC	1/3	Y	1800	1100	239	1003	335	877	396	729	460	486	486	-	-	-	-	-	-
ALX120-DD033EC	1/3	Y	1700	1544	341	1406	400	1279	436	1095	438	810	472	-	-	-	-	-	-
ALX120-DD050EC	1/2	Y	1800	1610	341	1477	400	1357	436	1201	438	955	472	571	484	-	-	-	-
ALX135-DD033EC	1/3	Y	1350	1578	414	1469	494	1341	574	1194	750	1009	865	-	-	-	-	-	-
ALX135-DD050EC	1/2	Y	1550	1843	414	1747	494	1645	574	1530	750	1405	865	1258	919	-	-	-	-
ALX135-DD075EC	3/4	Y	1800	2150	414	2075	494	2000	574	1900	750	1700	865	1600	919	1450	977	-	-
ALX150-DD033EC	1/3	Y	1250	2000	570	1800	499	1525	633	1225	812	-	-	-	-	-	-	-	-
ALX150-DD050EC	1/2	Y	1200	2133	570	2003	499	1842	633	1640	812	1430	866	1175	879	-	-	-	-
ALX150-DD075EC	3/4	Y	1480	2700	570	2550	499	2350	633	2100	812	1925	866	1700	879	1420	1072	-	-
ALX165-DD033EC	1/3	Y	1100	2264	860	2034	825	1787	1044	1470	1194	-	-	-	-	-	-	-	-
ALX165-DD050EC	1/2	Y	1250	2529	860	2328	825	2115	1044	1861	1194	1568	1320	-	-	-	-	-	-
ALX165-DD075EC	3/4	Y	1450	2909	860	2731	825	2546	1044	2362	1194	2132	1320	1879	1441	-	-	-	-

EC motors can be controlled using the built in potentiometer on motor or by using a 0 to 10 V controller, or by a remote potentiometer. Minimum motor speed 425 RPM (EC Models)

Model	Motor			Airflow (CFM) @ Static Pressure																			
	HP	Variable Speed	Max RPM	0" SP				1/2" SP				1" SP				1-1/4" SP				1-1/2" SP			
				CFM	BHP	FEI	FEPact (KW)	CFM	BHP	FEI	FEPact (KW)	CFM	BHP	FEI	FEPact (KW)	CFM	BHP	FEI	FEPact (KW)	CFM	BHP	FEI	FEPact (KW)
ALX150-DD100EC	1	Y	1700	2950	0.89	0.47	0.80	2625	0.92	0.84	0.82	2250	0.95	1.07	0.85	2050	0.95	1.15	0.85	1850	0.94	1.21	0.84
ALX165-DD100EC	1	Y	1600	3250	0.96	0.48	0.85	3000	0.99	0.88	0.88	2650	0.99	1.16	0.89	2500	0.98	1.30	0.88	2350	0.98	1.41	0.87
ALX180-DD100EC	1	Y	1200	3800	0.95	0.54	0.85	3325	0.99	0.95	0.88	2650	1.00	1.16	0.88	2200	0.99	1.17	0.88	-	-	-	-
ALX210-DD100EC	1	Y	900	4400	0.95	0.61	0.85	3600	0.99	1.02	0.88	2400	1.00	1.07	0.89	-	-	-	-	-	-	-	-

Consult our Delair fan selection software for fan curves and performance data. www.canarm.com/delair

ALX DOWNBLAST SERIES AIRFLOW RANGE WITH EC MOTORS

