



## WH60 & WH85 Whole Home Dehumidifiers



# Installation and Operation Manual

Read This Manual Carefully Before Proceeding

**Innovative Dehumidifier Systems**

[www.HumidityHappens.com](http://www.HumidityHappens.com)

<b>Table of Contents</b>	<b>Page</b>
Safety Instructions	3
Warranty Registration	3
How the Dehumidifier Works	4
Dehumidifier Specs	4
Basic Set Up - All Applications	5
Set Up - Connecting to HVAC System	6
- Dedicated Return	7
- Bypass Method	8
- Injection Method	8
Set Up - Remote Control System	9
- How to Use a Remote Control	10
Set Up - Standalone Installation	8
- Using the Dehumidifier Controls	11
- Indicator Lights on the Display	11
Unit Diagram	12
Maintenance	13
Troubleshooting	14
Warranty	15

# Safety Instructions

**Please read these instructions carefully and completely before continuing to install and operate this product. Failure to properly install and use this product will void the warranty. Please save these instructions for future reference.**

**Warning:** Failure to follow these instructions could result in serious injury or death.

- You **MUST** always unplug or turn off the power to the dehumidifier while installing or servicing the unit.
- You **MUST** connect this dehumidifier using a grounded electrical connection as required for ALL electrical appliances.
- **DO NOT** use a plug adaptor to bypass the ground prong on the plug.
- **DO NOT** use an extension cord with this product.
- **DO NOT** insert any objects or body parts into the inlet or discharge of this product.
- **DO NOT** use excessive amounts of water or other liquids to clean this product. Use **ONLY** a damp cloth to clean the exterior surfaces.
- You **MUST** connect your dehumidifier to a grounded, dedicated electrical connection that is GFCI protected with 15 amp capacity.

**Caution:** Failure to follow these instructions could result in injury or material property damage.

- This dehumidifier should be installed, maintained and serviced by a qualified technician. IF installed and maintained by the purchaser, that individual assumes ALL responsibility and liability for following ALL instructions in this Installation & Operation Manual.
- This dehumidifier **MUST** be installed in compliance with ALL local, state and national building codes applicable to the location where being installed.
- The drain hose **MUST** be installed to ensure proper flow of condensate to an appropriate drain source.
- **DO NOT** stand, sit or place objects on the dehumidifier.
- This unit is **NOT** designed for swimming pool applications.

## Warranty Registration

Your dehumidifier comes with an extensive warranty. See the last page of this manual for complete details.

For future reference, write down the model, serial number and date of purchase. This information is necessary for seeking assistance in the future and can be found on the data label on the side of the unit.

**Model Number:** \_\_\_\_\_ **Date of Purchase:** \_\_\_\_\_

**Serial Number:** \_\_\_\_\_

# How the Dehumidifier Works

Dehumidifiers can be used in a variety of ways to control the humidity level in your entire home. In the simplest terms, when the humidity level exceeds the set point of the humidity controller, the dehumidifier will energize. The internal fan and compressor will turn on, forcing air to be drawn across the evaporator coil, which is cooler than the dew point of the air, allowing the coil to remove water from the air and exit via the drain. The air is then reheated as it flows across the condenser coil and distributed back into the conditioned space.

## Dehumidifier Specs

<b>Model</b>	<b>WH85</b>	<b>WH60</b>
<b>Capacity (80°F / 60%)</b>	85 ppd	60 ppd
<b>Capacity (73°F / 60%)</b>	53.0 ppd	44.5 ppd
<b>Power Supply</b>	115V / 60 Hz	115V / 60 Hz
<b>Operating Temp.</b>	33 - 105°F	33 - 105°F
<b>Airflow @ 0.0" w.c.</b>	201 CFM	196 CFM
<b>Airflow @ 0.2" w.c.</b>	162 CFM	158 CFM
<b>Airflow @ 0.4" w.c.</b>	106 CFM	102 CFM

# Basic Set-Up - All Applications

## 1. Place the dehumidifier in an appropriate location.

(NOTE: If the unit has been turned or flipped so that the compressor did not remain upright, wait a minimum of 2 hours after placement to operate the unit.)

- The unit **MUST** be level after placement.
- The unit **MUST** be placed on a stable and supportive surface. Do not place unit directly on vapor barrier.
- If connecting directly to existing HVAC ducts, position unit so that the connecting ducts do **NOT** exceed 10' maximum from inlet to outlet.
- Place unit within proximity of a dedicated, 15 amp grounded, power supply.

## 2. Install Duct Collars

- Attach duct collars to inlet and outlet of dehumidifier with included screws. While not needed for freestanding installation, they can be used to help reduce the sound level. (NOTE: The 60 / 85 pint units will only have 6 screws provided as 2 screws can be reused from the unit.)

## 3. Connect Drain Line

- The drain line should be routed to a suitable drain option per local building code.
- THE DRAIN LINE MUST FLOW ON A CONTINUOUS DOWNWARD SLOPE WITH NO LOOPS OR DIPS.**
- Recommended Option:** Transition vinyl tube to PVC tube.
  - Cut a piece of 3/4" OD PVC tube approximately 6" long.
  - Attach the 6" piece to a 3/4"-90° elbow then attach the elbow to a 3/4" OD piece of PVC tube to the drain. Keep the length of the PVC tube to the drain as short as possible.

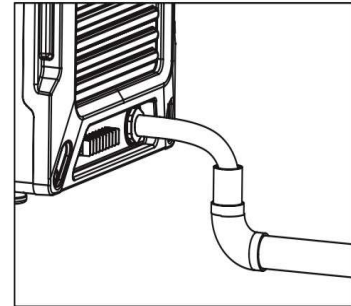

- Insert the open end of the dehumidifier drain tube into the 6" piece of PVC. **DO NOT** extend the tube into the elbow fitting.
- For a proper flow, a minimum downward slope of 1" per 10' of run is required. Support the PVC tubing so that it maintains this continuous downward slope.

## 4. Optional Condensate Pump or Float Switch

- NORMALLY OPEN OPERATION.** Use Auxiliary Terminals A5/A6 on the terminal strip.
  - The A5/A6 terminals can be used as a connection point for an external float switch or condensate pump with Normally Open Contacts.
  - If an E4 error occurs immediately, remove the wires from terminal strip and unplug the dehumidifier. Plug in dehumidifier with nothing attached to terminal strips. If E4 occurs again, contact Innovative Dehumidifiers. If not, move to the next step.
  - Double check that the external device is intended to be operated **Normally Open**. You may need to switch to Normally Closed (see below). Note that you may need to unplug the unit to reset the error code.
- NORMALLY CLOSED OPERATION.** Use Auxiliary Terminals A8/A9 on the terminal strip.
  - The A8/A9 on the terminal strip can be used as a connection point for an external float switch or condensate pump with Normally Closed contacts.
  - Remove the factory installed jumper between A8 and A9 terminals when you connect your accessory.

- If an E4 error occurs immediately, remove the wires from terminal strip, unplug the dehumidifier and replace the jumper. Plug in the dehumidifier with nothing attached to terminal strips. If E4 occurs again, contact Innovative Dehumidifiers. If not, remove the jumper, move to the next step.
- Double check that external device is intended to be **Normally Closed**. You may need to switch to Normally Open (see above). Note that you may need to unplug the unit to reset the error code.

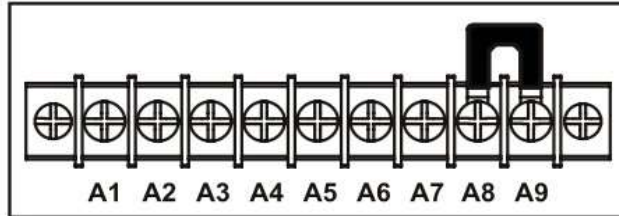

## 5. Connect the Dehumidifier to the power source

- This dehumidifier must be connected to a dedicated 15 amp, GFCI supported outlet. Follow local building codes for proper installation.
- Plug the unit into the outlet and finish the installation. Reference the “Using the Dehumidifier Controls” section when ready to start operation.

## Set Up – Connecting to HVAC System

This dehumidifier is set up for automatic detection of external controls. It is not necessary to make any adjustments to the dehumidifier display panel or control board. Once connected to the external controls, the dehumidifier buttons will no longer be active. (*NOTE: Check local building codes prior to connecting the dehumidifier to the buildings HVAC system.*)

### 1. Connect External Controls (See Diagram 1):

- A 24VAC input to terminals A3 and A4 from the HVAC controller will turn the machine “ON”. The power light on the dehumidifier display will light up and the two character LED display will read “CC” for “Central Control”. The unit will run until the HVAC controller reaches the desired humidity level.
- When the humidity level is satisfied, the HVAC controller will remove the external 24VAC supply signal. This will cause the power light on the dehumidifier display to turn off and the two character display to read “- -”.
- If a power outage occurs, the dehumidifier will return to the state it was in, then cycle on and off based on the 24VAC external control signal.
- If desired, the dehumidifier can turn the HVAC fan on. Simply put a jumper on the dehumidifier terminal strip between terminals A2 and A3. Connect terminal A1 back to the HVAC controller as shown in **Diagram 1**. The fan will come on whenever the dehumidifier is running.

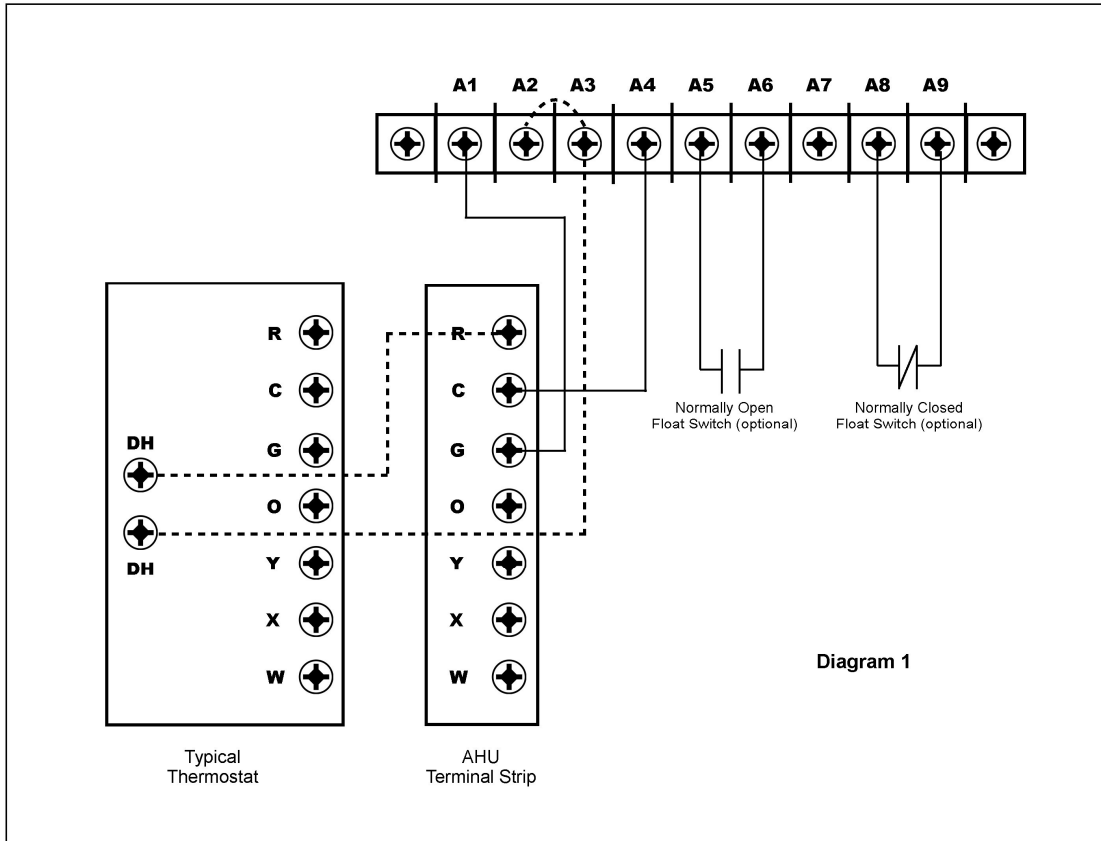

# HVAC Connection Options

## Option #1 - Dedicated Return

In this setup, the dehumidifier is connected to either the supply side or the return side of the air handler (supply side is shown).

**Notes:**

- The maximum combined length of ducting for the dehumidifier is 10'.
- The air handler fan should be set up to run while the dehumidifier is running.

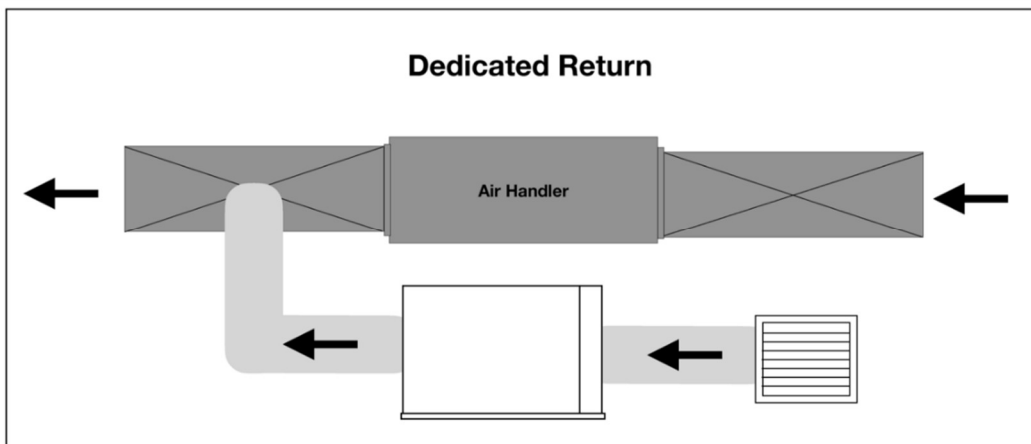

## Option #2 - Bypass Method

In this method, some air bypasses the air handler to be conditioned by the dehumidifier.

### Notes:

- For this method, you may need a damper to prevent back flow.
- The maximum combined length of ducting for the dehumidifier is 10'
- The air handler fan should be set up to run while the dehumidifier is running.

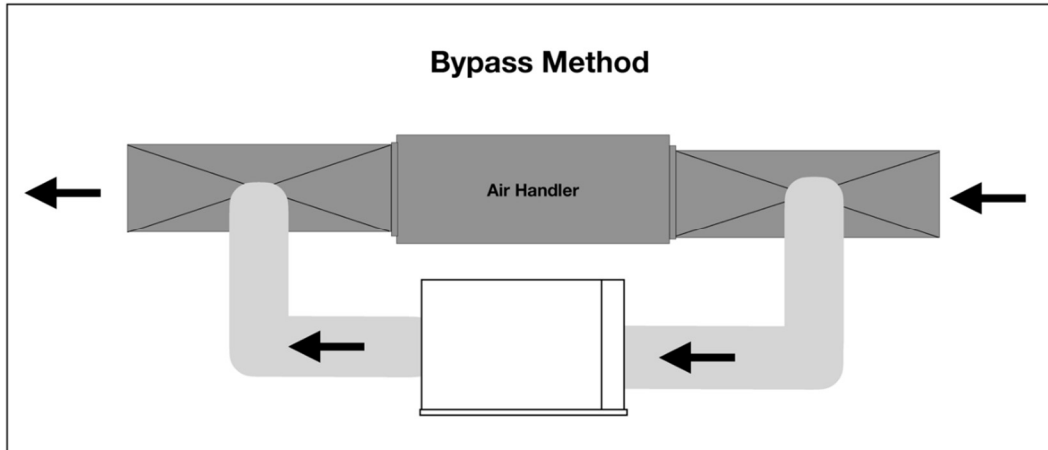

## Option #3 - Injection Method

In this setup, both sides of the dehumidifier are connected to the same side of the air handler (either supply or return).

### Notes:

- For this method, you may need a damper to prevent back flow.
- The maximum combined length of ducting for the dehumidifier is 10'.
- The air handler fan should be set up to run while the dehumidifier is running.

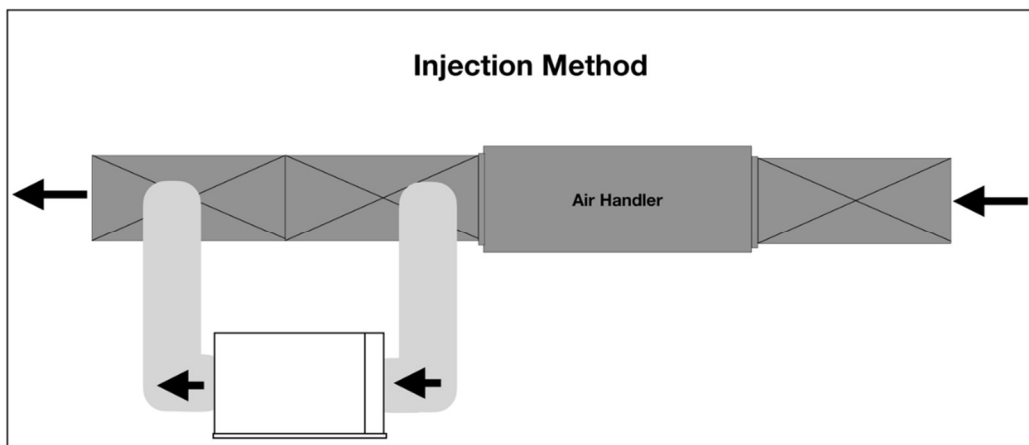

## Set up - Standalone Installation

It is also possible to use this dehumidifier in a single space without any ducting.



# Set Up - Remote Control System

You also have the option to give the dehumidifier independent ducts when you use a wired remote control. The remote plugs into a **CAT 5** port on the dehumidifier. This port is located next to the terminal strip on the back of the unit. This is useful if:

1. You install the dehumidifier in one room with the conditioned air ducted into a second room that contains the remote.
  - For this set up, select the ducted option using the “M” (mode) button on the remote.
2. You install the dehumidifier in a crawl space or basement and would like to control the dehumidifier from a different room.
  - For this set up, select the dehumidifier sensor option using the “M” (mode) button on the remote.

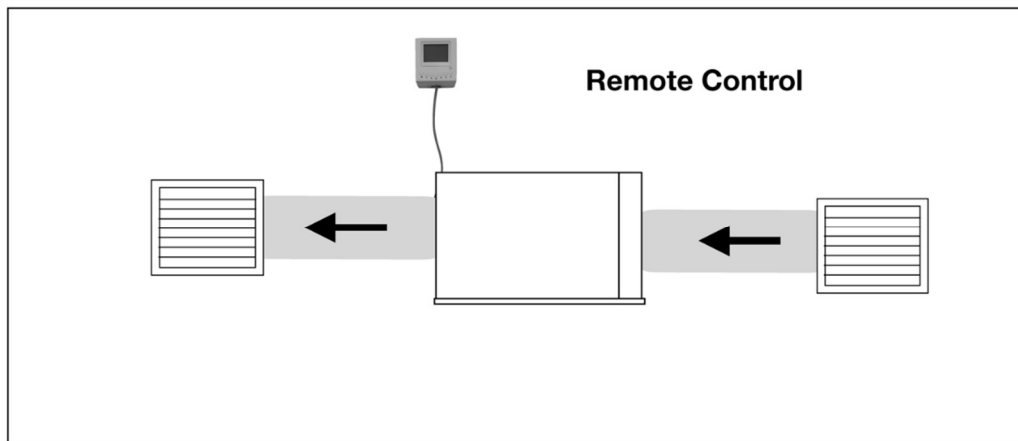

# How to Use a Remote Control

(See diagram)

1. **On / Off Power Button:** Press the on / off button and the machine will start running. Press the button again to turn the machine off.
2. **Up / Down Arrows:** Use the Up and Down arrow buttons to adjust the humidity level.
3. **Mode Button:** Use the Mode button to switch which sensor you are using, the sensor on the dehumidifier or the sensor on the remote control.
4. **Temperature Button:** The Temperature button changes the temperature reading on your remote. The remote comes standard in Celsius. Press this button once and it will switch to Fahrenheit.
5. **Continuous Button:** Press this button to switch the unit into continuous mode. "Cont" will appear on the display to indicate continuous mode.
6. **Drain Pump:** Pressing the pump button will remove water from the pump reservoir, so the unit can be safely moved or stored. *THIS FUNCTION IS ONLY AVAILABLE ON DEHUMIDIFIERS WITH BUILT-IN CONDENSATE PUMP.*

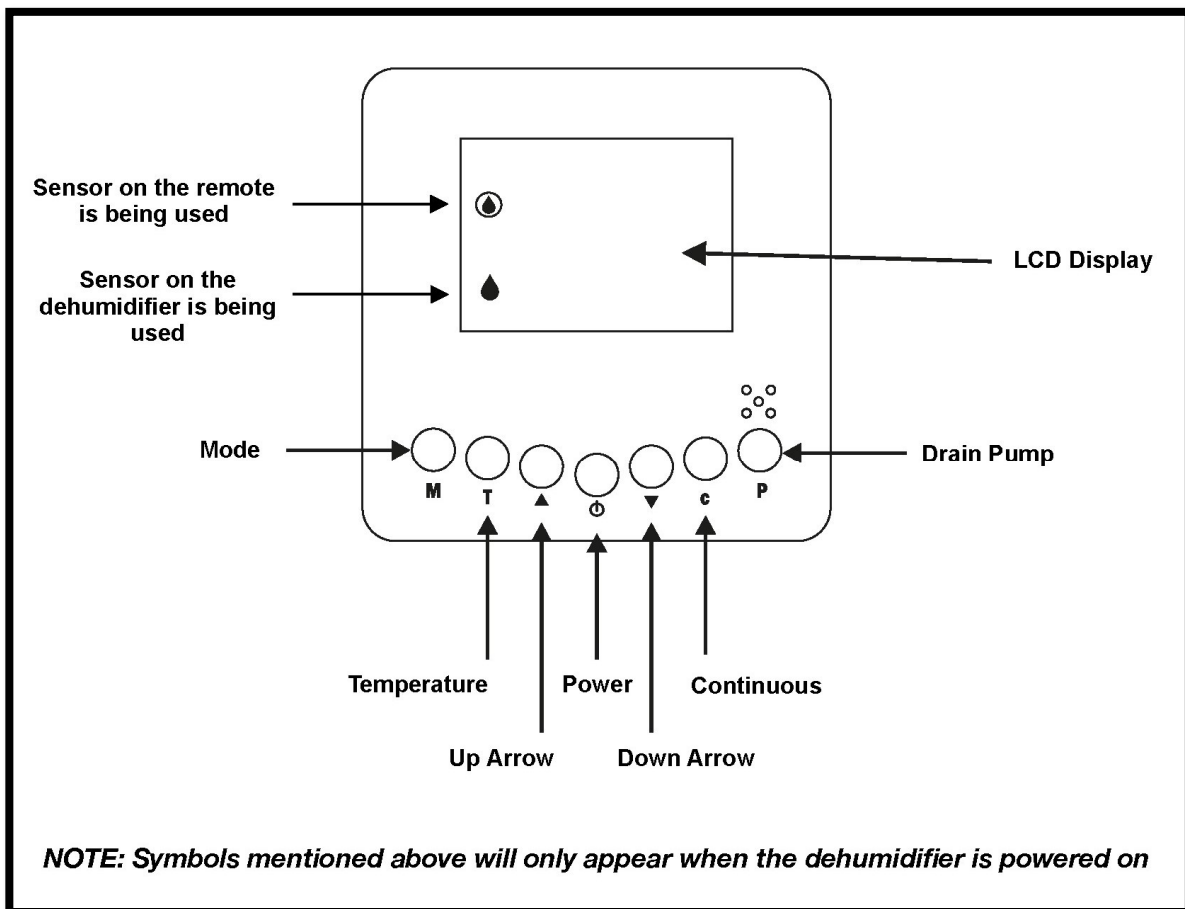

# Using the Dehumidifier Controls

**Note: While connected to the HVAC system, display functions on the dehumidifier will not work.**

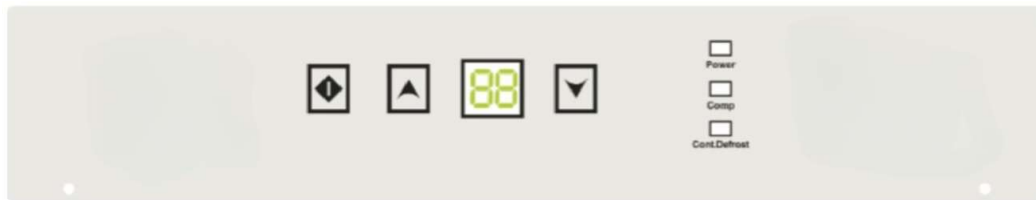

## 1. Power Button

- Use this button to turn the machine "ON" and "OFF".
- Press once to turn the machine "ON". You will hear two beeps and the  light will illuminate green (solid or flashing depending on mode).
- Press the button a second time to turn the machine "OFF". You will hear one beep as the machine shuts down. (Note that there is a 1 minute fan delay during shutdown).

## 2. Arrow Buttons

- Use the "UP" and "DOWN" arrow buttons to set the desired humidity level on the display screen. 
- This point can be set at any number between 36% - 90%. When the indoor humidity is higher than the set point, the machine will operate.
- Keep in mind that the displayed humidity levels are approximately +/-5%.

## 3. Continuous Mode

- To set the machine to run continuously, regardless of humidity level, simply press the "DOWN" arrow button to set the humidity below 36%.
- At this point, the continuous light will illuminate green and the display will read "CO".
- To switch back to normal operation, press the "UP" arrow button to raise the humidity set point above 36%.

# Indicator Lights on the Display

## 1. Humidity Display Screen

- When the unit is powered on, this screen shows the current humidity level of the space.
- When setting the desired humidity level, the screen will show the set point. After a brief delay, the display will go back to the current humidity of the space.

## 2. Power Indicator Light

- This light indicates that the unit is properly powered "ON" and ready to operate.
- Always make sure the unit is "OFF" prior to performing any service, unless otherwise indicated.
- If the humidity is above the set point, the light will be solid green and the machine will operate.
- If the humidity is below the set point, the unit will be in standby mode and the light will be flashing.

### 3. Continuous Mode / Auto Defrost Light



- a. When this light illuminates green, it indicates that the dehumidifier is in continuous mode.
- b. When the light illuminates red, it indicates the unit is in auto defrost mode and is clearing the evaporator coils of ice buildup.

### 4. Compressor Light



- a. When this light illuminates red, it indicates the compressor is "ON" but is warming up for operation.
- b. When this light changes to green, it indicates the compressor is operating normally.

## Unit Diagram

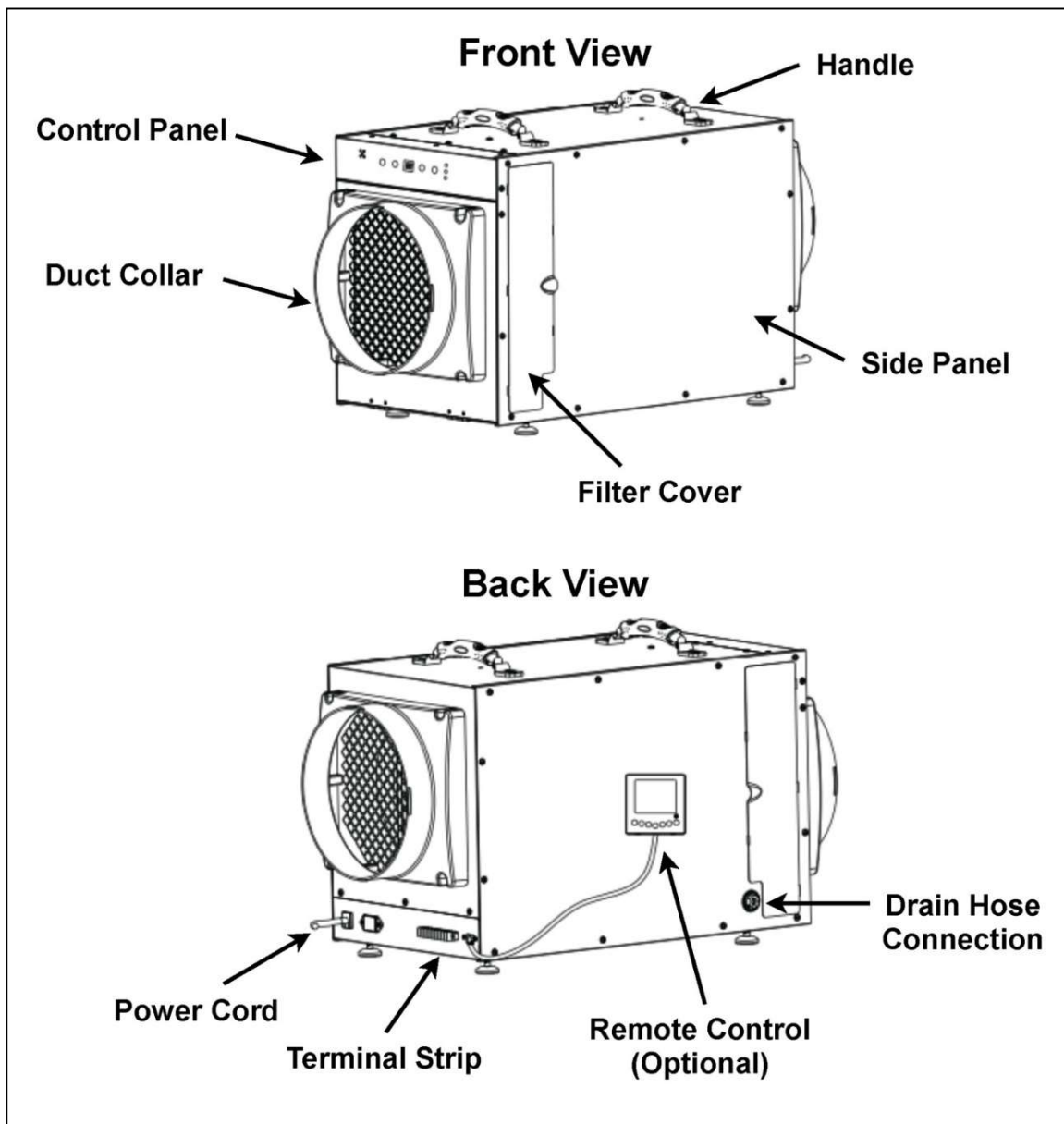

# Maintenance

**Warning: Always unplug the dehumidifier before performing any maintenance.**

## Cleaning the Exterior

Use a soft, damp cloth to clean the exterior of the unit. Do not use soap or solvents.

## Coil Maintenance

At least once per year, spray the coils with an approved coil cleaner. The coil cleaner should be a self-rinsing, foaming cleaner, such as WEB® Coil Cleaner.

## Filter Maintenance

1. Remove one of the filter doors from either side of the unit and set aside.
2. Slide out both filters, the pre-filter and pleated filter.
3. Clean both filters using a vacuum cleaner or replace as needed. Do NOT use soap or solvents on these filters.
4. Slide both filters back into the machine and re-install the filter door.

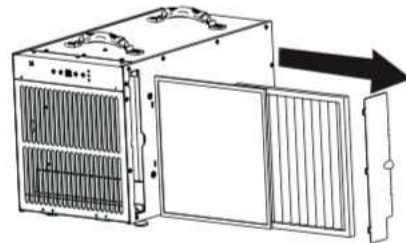

## Cleaning the Drain Tray

*(Complete approximately once per year, depending on the environment.)*

1. Unplug the dehumidifier.
2. Mix a 16 ounce solution of vinegar (4 ounces vinegar + 12 ounces water), or bleach (1 ounce bleach + 15 ounces water).
3. Remove the filter so you have access to the drain tray.
4. Pour the cleaning solution into the drain tray at the base of the coils. If any cleaning solution gets on the coils, flush with water.
5. Allow solution to soak for 15 minutes.
6. Pour in 32 ounces of clean water to flush out the drain line.

# Troubleshooting

<b>Symptom</b>	<b>Cause</b>	<b>Solution</b>
<b>Display is Blank</b>	Poor Connection	Verify that both ends of the display cable are plugged in
	Power Outage	Reset power
<b>No Airflow</b>	Filter is Dirty	Clean the filter
	Air Inlet or Outlet is Blocked	Clear the blockage
<b>Error Code: E1</b>	Humidity Sensor or Communication Error	Check to ensure that the sensor wire is connected at both ends. if no issues are visible, the sensor may be faulty.
<b>Error Code: E4</b>	Problem with Terminals	Verify that float switch and/or external pump is plugged in and working properly
<b>Error Code: LO</b>	Room Temperature is below 33°F	Increase the room temperature so it is within operating range (above 33°F). If error still displays, check sensor.
<b>Error Code: HI</b>	Room Temperature is above 105°F	Decrease the room temperature so it is within operating range (below 105°F). If error still displays, check the sensor
<b>Tripped GFCI Outlet or Breaker</b>	Not a Dedicated Circuit	Identify all sources connected to outlet and confirm source of trip. If it is dehumidifier, contact technical support. If not, move dehumidifier to dedicated circuit for future use.
	Defective GFCI Outlet	Replace Outlet
	Dirt, Dust, or Moisture on Outlet	Clean or Replace Outlet, as necessary
	Lightning or External Electrical Surge	Reset or Replace Breaker/GFCI, as necessary
	Possible Dehumidifier Issue	If none of above options work, contact technical support



## 5 Year Warranty

Innovative Dehumidifier Systems warrants the equipment to be free from defects in workmanship and materials for a period of 60 months after shipment. This warranty is limited, however, to the repair or replacement of defective equipment at the manufacturer's discretion. If it is necessary to return unit for service, customer is solely responsible for proper packaging and transportation costs to and from the service center. Customer must initiate warranty process by contacting IDS. Do not send any component or product back to IDS without a Return Material Authorization.

This limited warranty does not apply to any part or component that is damaged in transit or when handling, during installation, has been subject to misuse, has not been installed, operated or serviced according to the Seller's instructions, or has been operated beyond the seller's – rated capacity or has been altered in any way. Routine maintenance is not covered by this warranty. Lack of proper maintenance voids this warranty.

This warranty does not cover corrosion, freezing or acts of nature – flooding, fire, water damage, power surges, and hurricane or storm damage.

Seller's liability is limited to replacement of defective parts or components and does not include any cost of labor (including, but not limited to, labor to remove and/or reinstall any defective part), refrigerant or piping. Customer may elect to have unit fixed locally with prior authorization in which case required replacement parts will be sent to customer at customer's expense.

IDS shall not be responsible for loss of use of any product, loss of time, inconvenience, or damage to other equipment, or any other indirect or consequential damage with respect to property whether as a result of breach of warranty, neglect, or otherwise.

THE WARRANTIES AND LIABILITIES SET FORTH ARE IN LIEU OF ALL OTHER WARRANTIES EXPRESSED OR IMPLIED, IN LAW OR IN FACT, INCLUDING IMPLIED WARRANTIES OF MERCHANTABILITY AND FITNESS FOR PARTICULAR PURPOSE. IDS total liability, regardless of nature of claim shall not exceed original purchase price of the product. If a product or component is replaced while under warranty, the applicable warranty period shall not be extended beyond the original warranty time period.

The foregoing shall constitute the total liability of seller in the case of defective performance of all or any of the equipment or services provided to Buyer. Buyer agrees to accept and hereby accepts the foregoing as the sole and exclusive remedy for any breach or alleged breach of warranty by Seller.