

Thank you for purchasing a Built-To-Order Transition from HVACquick.com

Before Installing this equipment, please take a moment to inspect for damage it may have sustained during shipping. **DO NOT INSTALL DAMAGED EQUIPMENT.** If you suspect damage, contact us by phone at: 888-855-7229 or email at team@hvacquick.com

To minimize volume in shipping, our built-to-order transitions ship partially assembled. Included with this regular transition are:

- the Duct Adapter with sheet metal screws (HW-905) to mount it
- If you purchased the optional mounting brackets, 4 mounting brackets with sheet metal screws (HW-905) to mount them

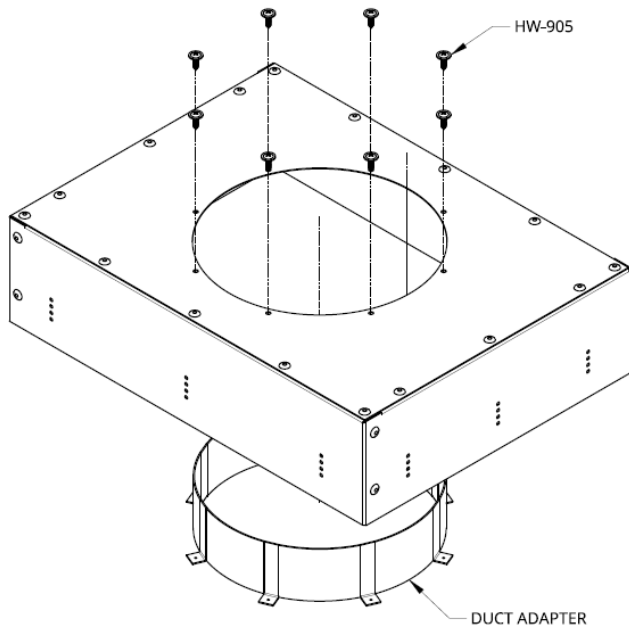

Installing the Duct Adapter:

Slide the duct adapter from within the box upward through the top plate. Secure it using the provided HW-905 sheet metal screws. (up to 12 screws depending on size purchased)

If you purchased the optional mounting brackets:

Mount the four brackets, as shown below, using the 12x HW-905 sheet metal screws. Please **NOTE:** the brackets can be mounted in multiple positions and upside down (not shown).

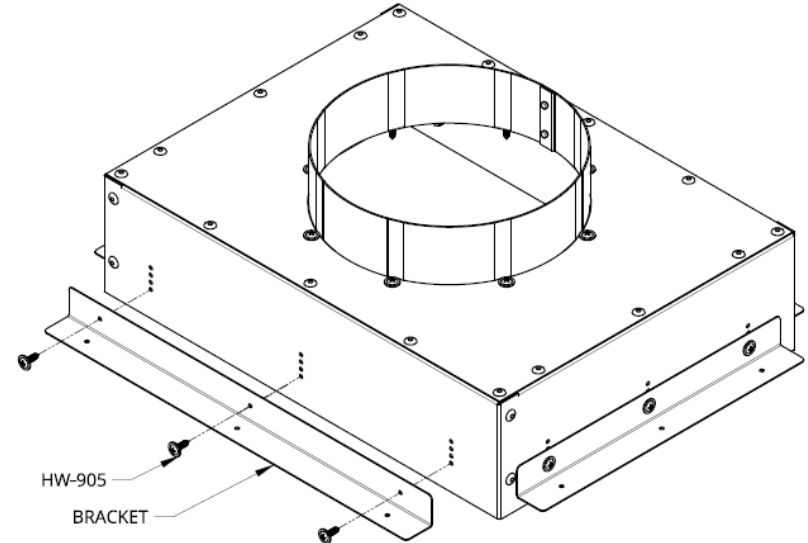

You are now ready to install the transition:

The basic transition can be mounted by screwing mounting screws (not included) through the side wall holes.

The transition with brackets can be mounted in multiple ways by screwing mounting screws (not included) through the bracket holes (see picture).

Install this equipment in compliance with all local codes and standards.

