

GREYSTONE

ENERGY SYSTEMS INC

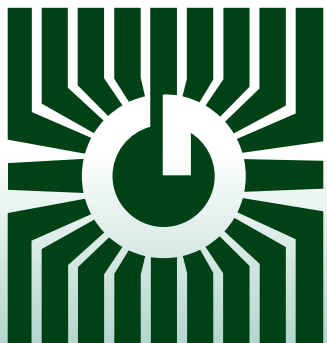

SPLIT-CORE CURRENT SWITCH SC Series



Precision power control/sensing

FEATURES:

- Split-Core
- Go/No Go or Field Adjustable Models
- Setpoint Adjustment Potentiometer (SC-610-200)
- Up to 200 amps Input Current
- Self-powered
- Add-on Command Relay Option

*Peace of mind
through reliable
current switches*

GREYSTONE HAS AN ISO 9001 REGISTERED QUALITY SYSTEM

DESCRIPTION:

The SC Series current switch monitors line current for electrical loads such as pumps, conveyors, lighting, heaters or fans and closes the output contacts when the trip point is exceeded. The SC-GnG-200 has a factory set trip point of 2 Amps to provide Go/No Go status operation. The SC-610-200 has a trip setpoint that is adjustable between 2 to 200 Amps by rotating the adjustment potentiometer.

The sensor requires no external power as it is totally powered by induction from the AC line being monitored. The switch output is normally open and when the input current exceeds the trip setpoint the switch closes to provide an on/off digital signal to the controller

SPECIFICATION:

Current Setpoint:.....	Fixed at 2 Amps (SC-GnG-200) 2 to 200 Amps (SC-610-200)
Maximum Input Current:.....	200 Amps continuous
Sensor Power:.....	Self-powered
Output Type:.....	Solid-state mosfet
Output Switch Action:.....	Normally open
Output Switch Ratings:.....	30 Vac/Vdc, 500 mA Max.
Indication:.....	Power and Status LED (SC-610-200 Only)
Von @ 24 Vdc at 150mA:.....	< 50 mV
Frequency:.....	50/60 Hz
Response Time:.....	200 mS Typical
Insulation Class:.....	600 Vac, insulated conductors
Operating Temperature:.....	-15 to 50 °C (5 to 122 °F)
Operating Humidity:.....	5 to 90% RH non-condensing
Terminal Block:.....	14 to 22 AWG
Dimensions:.....	76 x 79 x 24.9 mm (3 x 3.1 x 0.98 in)
Sensor Aperture:.....	20.3 mm (0.8")
Enclosure Material:.....	ABS/PC, UL94 V-0
Agency Approvals:.....	cULus Listed

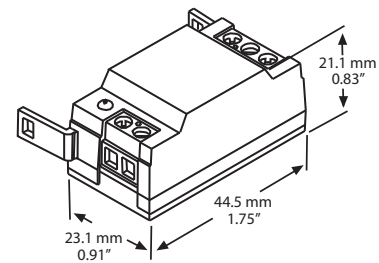
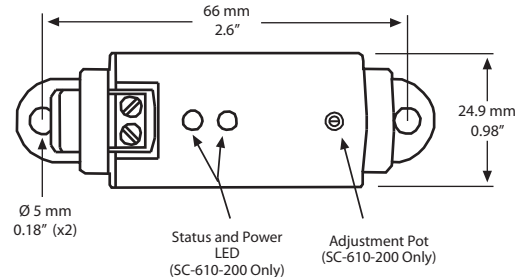
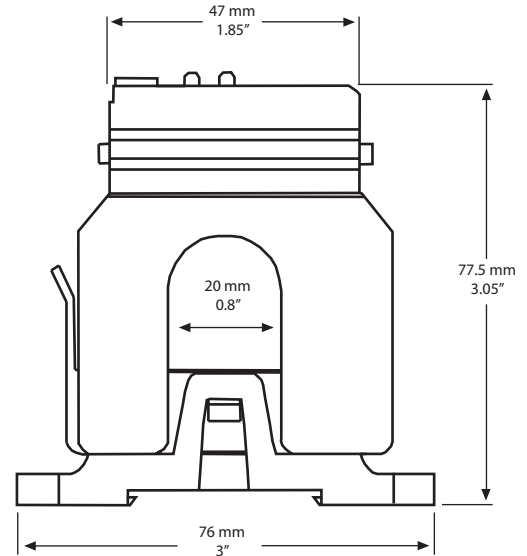

ORDER INFORMATION:

SC-GnG-200	Go/No Go
SC-610-200	Adjustable

ACCESSORIES: CSR Series Command Relays

(See CSR brochure for complete specifications)
(Order Separately)

CSR-112	12 Vac/dc
CSR-124	24 Vac/dc



GREYSTONE
ENERGY SYSTEMS INC

Greystone Energy Systems Inc.
150 English Drive, Moncton, N.B.
Canada E1E 4G7

(506) 853-3057 Fax: (506) 853-6014
North America: 1-800-561-5611
e-mail: mail@greystoneenergy.com
www.greystoneenergy.com



Greystone Energy Systems Inc. is one of North America's largest ISO registered manufacturers of HVAC sensors and transducers for Building Automation Management Systems.

We have conscientiously established a worldwide reputation as an industry leader by maintaining leading-edge design technology, prompt technical support, and a commitment to on-time deliveries. We take pride in our Quality Management System which is ISO 9001 certified, assuring our customers of consistent product reliability.

GREYSTONE HAS AN ISO 9001 REGISTERED QUALITY SYSTEM