

# GREYSTONE ENERGY SYSTEMS INC

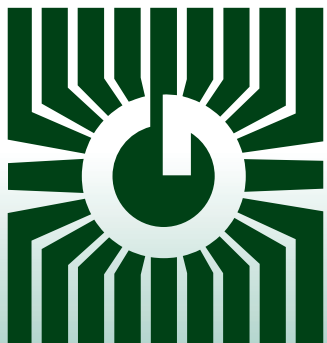

## MINI-CURRENT SENSOR CS-6XX Series



### Precision power control/sensing

#### FEATURES:

- Solid Core
- Analog Output
- Up to 100 amps input current
- Small, Compact Design

*Peace of mind  
through reliable  
current sensors*

GREYSTONE HAS AN ISO 9001 REGISTERED QUALITY SYSTEM

## DESCRIPTION:

The CS-6XX-XX series of current sensors monitor line current for electrical loads such as pumps, conveyors, machine tools or fans and provide an output of 4-20 mA, 0-5 Vdc or 0-10 Vdc (Model specific) to represent the load current.

The CS-650 & CS-651 series require no external power supply as they are totally powered by induction from the AC line being monitored. The CS-652 series is loop-powered and require an external 15-30 Vdc power supply.

## SPECIFICATION:

Measurement Range:.....	10/20/50 Amps (Model specific)
Maximum Input Current:.....	100 Amps continuous
Accuracy:.....	± 1% FSO
Sensor Power:.....	Self-powered (CS-650 & CS-651) 15-30 Vdc, Loop-powered (CS-652)
Output Type:.....	0-5 Vdc, 0-10 Vdc or 4-20 mA
Output Load:.....	1 MΩ Typical (CS-650 & CS-651) 250 Ω Typical (CS-652)
Loading Error:.....	Add 1.2% error with 100 KΩ (CS-650 & CS-651 Only)
Frequency:.....	50/60 Hz
Response Time:.....	<250 mS Typical (0-90%)
Insulation Class:.....	600 Vac, insulated conductors
Operating Temperature:.....	-15 to 60 °C (5 to 140 °F)
Operating Humidity:.....	5 to 90% RH non-condensing
Terminal Block:.....	14 to 22 AWG
Dimensions:.....	48 x 49 x 21 mm 1.9x 1.93 x 0.83 in
Sensor Aperture:.....	0.45 in (11.4 mm)
Enclosure Material:.....	ABS/PC, UL94 V-0
Agency Approvals:.....	cULus Listed

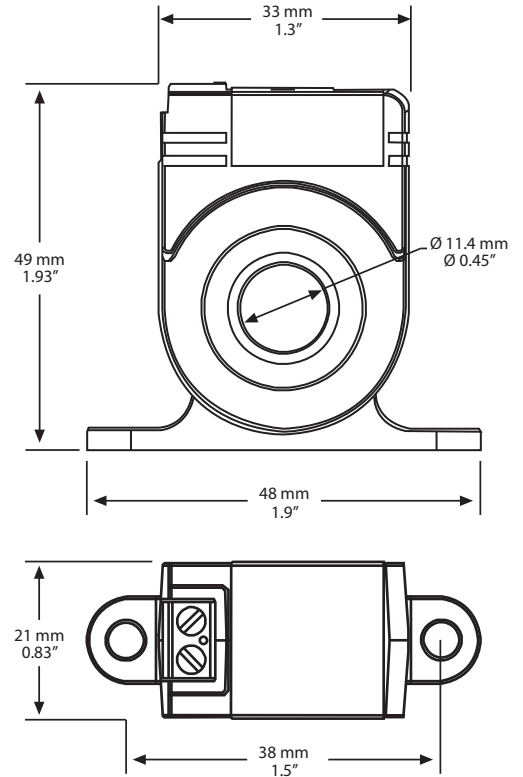

## PRODUCT ORDERING INFORMATION

MODEL	Output Signal
CS-650	0-5 Vdc, Self-powered
CS-651	0-10 Vdc, Self-powered
CS-652	4-20 mA, Loop-powered

CODE	Input Range
10	0-10 Amps
20	0-20 Amps
50	0-50 Amps

CS650 - 10

Current Sensor, 0-5 Vdc Output, 0-10 Amp Input

Greystone Energy Systems, Inc. reserves the right to make design modifications without prior notice.



**GREYSTONE**  
ENERGY SYSTEMS INC

Greystone Energy Systems Inc.  
150 English Drive, Moncton, N.B.  
Canada E1E 4G7

(506) 853-3057 Fax: (506) 853-6014  
North America: 1-800-561-5611  
e-mail: mail@greystoneenergy.com  
www.greystoneenergy.com



**RoHS**  
COMPLIANT



*Greystone Energy Systems Inc. is one of North America's largest ISO registered manufacturers of HVAC sensors and transducers for Building Automation Management Systems.*

*We have conscientiously established a worldwide reputation as an industry leader by maintaining leading-edge design technology, prompt technical support, and a commitment to on-time deliveries. We take pride in our Quality Management System which is ISO 9001 certified, assuring our customers of consistent product reliability.*

GREYSTONE HAS AN ISO 9001 REGISTERED QUALITY SYSTEM