

GREYSTONE ENERGY SYSTEMS INC

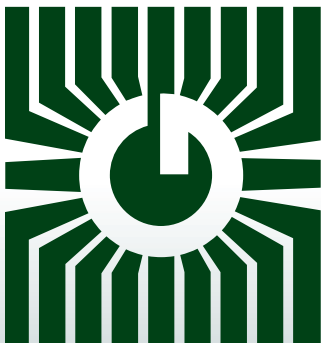

**CURRENT SWITCHES
HIGH OUTPUT**



Precision power control/sensing

FEATURES:

- Solid Core
- Adjustable trip levels
- Up to 200 amps input current
- High current output

*Peace of mind
through reliable
current monitoring*

GREYSTONE HAS AN ISO 9001 REGISTERED QUALITY SYSTEM

AC CURRENT SWITCHES CS-325

ADJUSTABLE CURRENT-OPERATED SOLID-STATE RELAYS FOR SWITCHING AC CIRCUITS



FEATURES:

- Self-powered and no insertion loss
- True digital switching and no leakage
- Small compact size
- Jumper-selectable ranges
- Easy field adjustment
- Input / Output isolation via current transformer
- Solid-state reliability
- Solid, reliable mounting method

DESCRIPTION:

The CS-325 series of AC current switches are solid-state switches that activate a contact closure whenever the monitored primary circuit current exceeds a pre-set level. Models are available to switch various load types as indicated in the Product Ordering Chart. All models include a multi-turn adjustment to set the trip threshold to the desired value. They monitor up to 200 Amps and feature jumper selectable ranges. All models are CSA certified or UL approved and CE compliant.

SPECIFICATIONS:

Setpoint Range	1-200 Amps	Enclosure Size (H x W x D)	Solid Core - 49 x 87 x 25 mm (1.95 x 3.45 x 1.0")					
	<table border="1"> <thead> <tr> <th>Jumper</th> <th>CS-325 Amp-Turns</th> </tr> </thead> <tbody> <tr> <td>Low (none)</td> <td>1-6</td> </tr> <tr> <td>Medium</td> <td>6-40</td> </tr> <tr> <td>High</td> <td>40-200</td> </tr> </tbody> </table>			Jumper	CS-325 Amp-Turns	Low (none)	1-6	Medium
Jumper	CS-325 Amp-Turns							
Low (none)	1-6							
Medium	6-40							
High	40-200							
Wiring Connections	Solid Core - Barrier strip	Enclosure Material	UL 94V-0 flammability rated ABS Insulation Class 600V					
Hysteresis	< 2% FS max.	Certification	CSA or UL (see below table), CE					
Operating Temperature	0 to 40°C (32 to 104°F)	Power Supply	None - Self-powered					
Response Time	< 200 mS	AC Conductors Hole	Solid Core - 20mm (0.8") diameter					

CURRENT SWITCH: PRODUCT ORDERING INFORMATION

Model	Output Type	Switch V Max	I Max	Von@24Vdc @ 150 mA	Leakage Current	Power LED	Status LED	Auto Range	Input I Min	Input I Max	Approval
CS-325*	Triac	250Vac	1 Amp	n/a	<5 mA	No	No	No	1.25A	200A	cCSAus
CS-325-NS*	Triac	250Vac	1 Amp	n/a	<1 mA	No	No	No	1.25A	200A	cCSAus

* The CS-325 with the snubber circuit is best used to switch high-current inductive loads such as small fan motors. The CS-325-NS is best used to switch resistive or low-current inductive loads such as relays or lights.

AC CURRENT SWITCH

CS-425-HC Series



CURRENT-OPERATED SOLID-STATE RELAYS FOR SWITCHING AC CIRCUITS WITH TIME DELAY

FEATURES:

- Self-powered and no insertion loss
- True digital switching and no leakage
- Small compact size
- 0, 5, 10, or 15 minutes time delay models
- Input / Output isolation via current transformer
- Solid-state reliability
- Solid, reliable mounting method

APPLICATIONS:

Direct control of AC loads, such as dryer booster fans, in response to the current of a monitored AC circuit

DESCRIPTION:

The CS-425-HC products are solid-state current switches with N.O. triac outputs to control high-current line-voltage AC loads. All models have a factory set trip level of approximately 1 Amp and require no field adjustment for easy installation. Internal circuits are powered by induction from the line being monitored and all models are cULu certified.

SPECIFICATIONS:

Maximum Core Current	50 Amps	Turn on time	<200 mS
		Turn off time	0, 5, 10 or 15 minutes (factory set)
Operating Temperature	0 to 40°C (32 to 104°F)	Operating Humidity	0 - 95% RH non-condensing
Trip Set-Point	Approximately 1 Amps	Material	UL 94V-0 flammability rated ABS Insulation Class 600V
Enclosure Size (H x W x D)	49 x 87 x 25 mm (1.95" x 3.45" x 1")	Mounting Holes	2 x 5 mm holes spaced 76 mm on base (2 x 0.19" holes spaced 3" on base)
AC Conductor Hole	20 mm (0.8") Diameter	Switch Type	Solid-state triac
Switch Rating	120 Vac @ 2.5 Amps Max.	Off-state Leakage	<1 mA

DRYER BOOSTER FAN OPERATION:

The CS-425-HC series can operate a dryer booster fan directly. These devices sense when a clothes dryer is drawing 1 Amp of current and then closes the output switch to activate the dryer vent booster fan. When the dryer cycle is complete and the current drops below the threshold, the output switch will remain closed for a pre-set delay time to allow heat to be removed from the vent before the switch is opened again. The device output can switch 120 Vac loads up to 2.5 Amps.

CURRENT SWITCH: PRODUCT ORDERING INFORMATION

Model	Output Type	Switch V Max.	Switch I Max.	Leakage Current	Input I Min.	Input I† Max.	Time Delay (off)	Approval
CS-425-HC-0	Triac	120 VAC	2.5 Amp	<1 mA	~1 Amp	50 Amps	none	cULus
CS-425-HC-5	Triac	120 VAC	2.5 Amp	<1 mA	~1 Amp	50 Amps	5 minutes	cULus
CS-425-HC-10	Triac	120 VAC	2.5 Amp	<1 mA	~1 Amp	50 Amps	10 minutes	cULus
CS-425-HC-15	Triac	120 VAC	2.5 Amp	<1 mA	~1 Amp	50 Amps	15 minutes	cULus

Solid Core CS-325 Series Current Switch

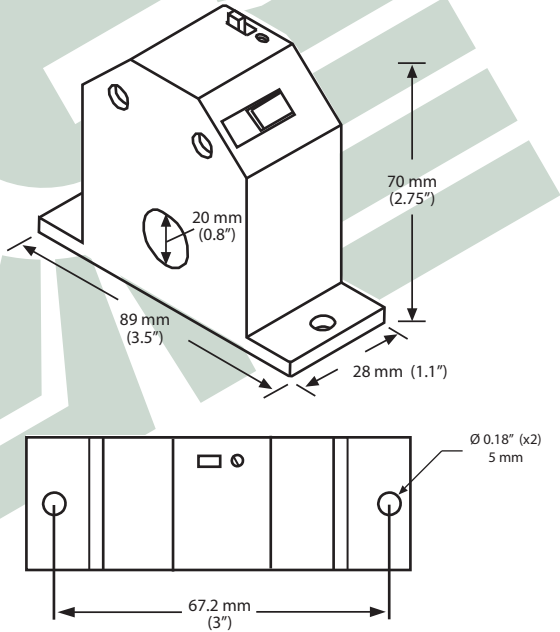

Solid Core CS-425 Series Current Switch

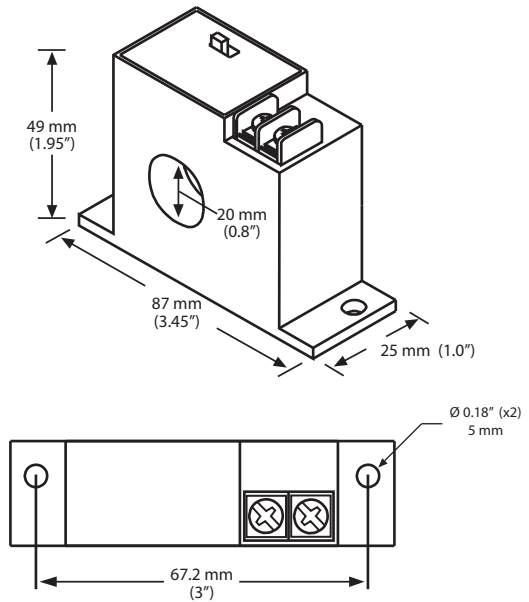

Typical Installation

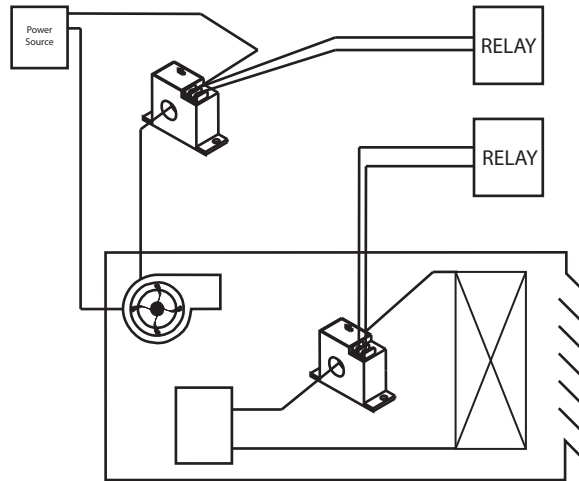

GREYSTONE

ENERGY SYSTEMS INC

Greystone Energy Systems Inc.
150 English Drive, Moncton,
New Brunswick, Canada E1E 4G7
(506) 853-3057 Fax: (506) 853-6014
North America: 1-800-561-5611
e-mail: mail@greystoneenergy.com
www.greystoneenergy.com



RoHS
US COMPLIANT



Greystone Energy Systems Inc. is one of North America's largest ISO registered manufacturers of HVAC/R sensors and transmitters for Building Automation Management Systems.

We have conscientiously established a worldwide reputation as an industry leader by maintaining leading-edge design technology, prompt technical support, and a commitment to on-time deliveries. We take pride in our Quality Management System which is ISO 9001 certified, assuring our customers of consistent product reliability.

GREYSTONE HAS AN **ISO 9001** REGISTERED QUALITY SYSTEM