

## Command Relay CSR-112 / CSR-124



### SPECIFICATIONS:

Coil Voltage:.....	<b>CSR-112:</b> 12 Vdc $\pm$ 10%
	<b>CSR-124:</b> 24 Vac/dc $\pm$ 10%
Coil Current:.....	<b>CSR-112:</b> 25 mA maximum
	<b>CSR-124:</b> 13 mA maximum
Relay Contacts:.....	SPDT Form C (NO + NC)
Contact Rating:.....	5A @ 250 Vac/30 Vdc Resistive
	2A @ 250 Vac/30 Vdc Inductive
Contact Resistance:.....	30 m $\Omega$ maximum
Operating Temperature:.....	-15 to 60 °C (5 to 140 °F)
Operating Humidity:.....	5 to 90 % RH, non-condensing
Wiring Connection:.....	Terminal block (14 to 22 AWG)
Dimensions:.....	50.8 x 35.6 x 21.1 mm
	(2 x 1.4 x 0.83")
Enclosure Material:.....	ABS/PC, UL94 V-0

### DESCRIPTION:

The **CSR-112** and **CSR-124** command relay attaches to the side of any full-size CS or SC type sensor or switch and adds a form C relay function. It provides line voltage switching with control either from an automation system digital output or from a CS/SC current switch. A status LED indicates the relay state and the relay output features both a normally-open and a normally-closed contact.

The CSR-CS/SC combination provides a convenient solution when status indication and motor control are needed at a single location. The CSR can accept a digital control signal from the controller to activate the relay contacts which can be used to provide power to the motor contactor to start the motor. The CS/SC switch will then provide a digital proof-of-flow signal to the controller to indicate motor status

### FEATURES:

- Can be mounted to any CS or SC product for easier installation (Not applicable for CS Mini versions)
- Convenient Relay Status LED
- Can be factory assembled with any CS or SC product
- SPDT Form C relay contacts
- Environmentally-friendly cadmium-free contacts
- Ideal for switching contactors, solenoids and motors
- Small compact size

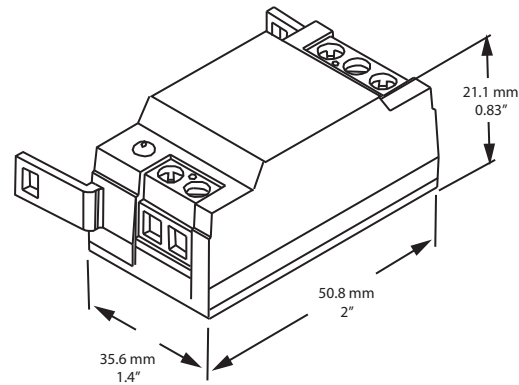
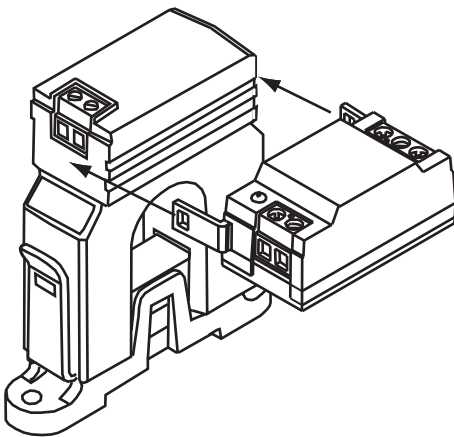

# GREYSTONE

ENERGY SYSTEMS INC

Greystone Energy Systems Inc.  
150 English Drive, Moncton,  
New Brunswick, Canada E1E 4G7  
(506) 853-3057 Fax: (506) 853-6014  
North America: 1-800-561-5611  
e-mail: mail@greystoneenergy.com  
www.greystoneenergy.com



RoHS  
COMPLIANT



*Greystone Energy Systems Inc. is one of North America's largest ISO registered manufacturers of HVAC/R sensors and transmitters for Building Automation Management Systems.*

*We have conscientiously established a worldwide reputation as an industry leader by maintaining leading-edge design technology, prompt technical support, and a commitment to on-time deliveries. We take pride in our Quality Management System which is ISO 9001 certified, assuring our customers of consistent product reliability.*

GREYSTONE HAS AN ISO 9001 REGISTERED QUALITY SYSTEM