

GREYSTONE ENERGY SYSTEMS INC

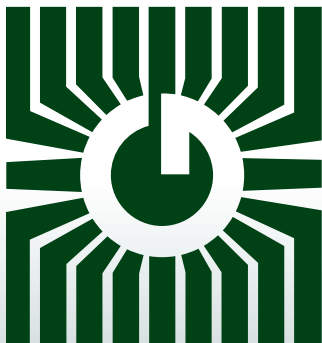

CARBON DIOXIDE (CO₂) DETECTORS w/ BACnet® or ModBus Communications CDD3 Series



BACnet is a registered trademark of BACnet. All other trademarks, registered trademarks, and trade names are the property of their respective owners. BTL is a registered trademark of the BTL Testing Laboratory.



Precision carbon dioxide control/sensing

FEATURES:

- BACnet® or ModBus Communication
- BTL Listed (B-ASC)
- Optional RH and/or Temperature
- Optional Setpoint and/or Override
- Optional on-board relay
- Optional LCD display
- Custom logos available

*Peace of mind
through reliable
gas monitoring*

GREYSTONE HAS AN ISO 9001 REGISTERED QUALITY SYSTEM

CO₂ DETECTOR w/ BACnet® or ModBus Communications

SPECIFICATIONS:

General Specifications:

Power Supply.....	20-28 Vac/dc (non-isolated half-wave rectified)
Consumption.....	80 mA max @ 24Vdc, 140 mA max @ 24Vac with all options
Protection Circuitry.....	Reverse voltage protected, overvoltage protected
Operation Conditions.....	0°-50°C (32°-122°F), 0-95% RH non-condensing.
Sensor Coverage Area.....	100 m ² (1000 ft ²) typical
Wiring Connections.....	Screw terminal block (14 to 22 AWG)
External Dimensions.....	Space: 84mm W x 119mm H x 29mm D (3.3" x 4.7" x 1.15") Duct: 145mm W x 100mm H x 63mm D (5.7" x 3.95" x 2.5") Duct Probe: 177mm (7") long x 25.4mm (1") diameter
Enclosure Ratings.....	Space: IP30 (NEMA 1) Duct: IP65 (NEMA 4X)

CO₂ Signal:

Measurement Type.....	Non-Dispersive Infrared (NDIR), diffusion sampling
Range.....	0 - 2000 ppm
Standard Accuracy.....	±75 PPM @ 1000 ppm @ 22°C (72°F) when compared to certified calibration gas
Temperature Dependence.....	0.2% FS per °C
Stability.....	< 2 % FS over life of sensor (15 years typical)
Pressure Dependence.....	0.13% of reading per mm Hg
Altitude Correction.....	Programmable from 0-5000 ft via BACnet® or ModBus
Response Time.....	<2 minutes for 90% step change typical
Warm-up Time.....	<2 minutes

BACnet® Interface:

Hardware.....	2-wire RS-485
Software.....	Native BACnet® MS/TP protocol
Baud Rate.....	Locally set to 9600, 19200, 38400 or 76800
MAC Address Range.....	Locally set to 0-127 (factory default is 3), (63 devices max on one daisy chain)

ModBus Interface:

Hardware.....	2-wire RS-485
Software.....	Native ModBus MS/TP protocol (RTU or ASCII)
Baud Rate.....	Locally set to 300, 600, 1200, 2400, 4800, 9600, 19200, 38400, 57600, 76800 or 115200
Slave Address Range.....	Locally set to 0-64 (factory default is 1), (32 devices max on one daisy chain)

Optional Temperature Signal:

Sensing Element.....	10K thermistor, ±0.2°C (±0.4°F)
Resolution.....	0.1°C (0.2°F)
Range.....	0° to 35°C (32° to 95°F)

Optional RH Signal:

Sensing Element.....	Thermoset polymer based capacitive
Accuracy.....	± 2% RH
Range.....	0 - 100% RH, non-condensing
Resolution.....	1% RH
Hysteresis.....	± 3% RH
Response Time.....	15 seconds typical
Stability.....	± 1.2% RH typical @ 50% RH in 5 years

Optional Relay Output:

Contact Ratings.....	Form A contact (N.O.), 2 Amps @ 140 Vac, 2 Amps @ 30 Vdc
Relay Trip Point.....	Programmable 500-1500 ppm via BACnet® or ModBus
Relay Hysteresis.....	Programmable 25-200 ppm via BACnet® or ModBus

Optional LCD Display:

Resolution.....	1 ppm CO ₂ , 1% RH, 1°C (1°F)
Size.....	1.4" w x 0.6" h (35 mm x 15 mm) alpha-numeric 2 line x 8 character
Backlight.....	Enable or disable via keypad

Optional Override Switch.....Front panel push-button available as BACnet® object or ModBus register

Optional Setpoint Control.....Front panel push-buttons available as 0 to 100% as BACnet® object or ModBus register

FEATURES:

- Menu driven set-up
- 0-2000 PPM CO₂ range
- BACnet® or Modbus Communication
- Patented self-calibration algorithm
- Guaranteed 5 year calibration interval
- Easily field calibrated
- Accepts AC/DC power

OPTIONS:

- LCD
- Humidity and/or Temperature
- Setpoint Adjustment
- Override Switch
- Control relay
- Custom Logos

PRODUCT ORDERING INFORMATION:

MODEL	Description
CDD3A	Carbon Dioxide Detector (CO ₂), Non-Dispersive Infrared (NDIR) sensor w/ BACnet® Communications
CDD3B	Carbon Dioxide Detector (CO ₂), Non-Dispersive Infrared (NDIR) sensor w/ Modbus Communications

CODE	Enclosure
10	Space
20	Duct

CODE	LCD Display
0	Concealed
1	Viewable

CODE	Configurations
-	CO ₂ Only
RH	CO ₂ , Humidity and Temperature
T	CO ₂ and Temperature

CODE	Setpoint Adjustment (Available on Space only)
-	No Setpoint Adjustment
P	Setpoint Adjustment

CODE	Momentary Override (Available on Space only)
-	No Override
S	Override Switch

CODE	Relay Output
-	No Relay
R	Relay

CDD3A	10	1	RH	P	S	-	← Typical Model Number
--------------	-----------	----------	-----------	----------	----------	----------	------------------------

Example: Space CO₂, 0-2000 ppm w/ BACnet®, LCD, Setpoint Adjustment, & Override Switch

Greystone Energy Systems Inc. reserves the right to make design modifications without prior notice.

BACnet® COMMUNICATION



BACnet® is a data communication protocol for building automation and control networks. The detector communicates on a standard 2-wire RS-485 MS/TP (master-slave/token-passing) network designed to run at speeds from 9600 to 76800 baud over twisted pair wiring.

BACnet is a registered trademark of ASHRAE. ASHRAE does not endorse, approve or test products for compliance with ASHRAE standards. Compliance of listed products to the requirements of ASHRAE Standard 135 is the responsibility of BACnet International (BI). BTL is a registered trademark of BI.

MODBUS COMMUNICATION

Modbus is a network protocol for industrial manufacturing environments. The detector communicates on a standard Modbus network using either of two transmission modes: RTU (Remote Terminal Unit) or ASCII (American Standard Code for Information Interchange). The hardware interface is RS-485. Select the desired mode along with the other parameters using the Configuration Menu.

ACLP SOFTWARE AND 5-YEAR CALIBRATION GUARANTEE

ACLP SOFTWARE

ACLP (Automatic Calibration Logic Program) software utilizes the computing power in the sensor's on-board microprocessor to remember the lowest CO₂ concentration that takes place every 24 hours. The sensor assumes this low point is at outside levels. The sensor is also smart enough to discount periodic elevated readings that might occur if for example a space was used 24 hours per day over a few days. Once the sensor has collected 14 days worth of low concentration points, it performs a statistical analysis to see if there has been any small changes in the sensor reading over background levels that could be attributable to sensor drift. If the analysis concludes there is drift, a small correction factor is made to the sensor calibration to adjust for this change.

5-YEAR CALIBRATION GUARANTEE

Based on the results of years of testing of ACLP software, Greystone now offers a 5-year calibration guarantee on all its CDD series wall and duct mount sensors used for CO₂ based ventilation control when operated in an environment that can utilize ACLP software. If the sensor is found to be out of calibration more than 150 PPM as compared to a calibration gas or recently calibrated reference, Greystone will provide a free factory calibration of the sensor if returned to Greystone. This guarantee only applies if the sensor is operated in an environment where inside levels periodically drop to outside concentrations (i.e. during evenings or weekends when there is no occupancy) as is required by ACLP software. If a space does not experience a periodic drop to outside levels (i.e. where occupancy is 24 hours, 7 days/week), ACLP software should be deactivated. With ACLP deactivated, calibration may be required every 2 to 3 years.

DIMENSIONS

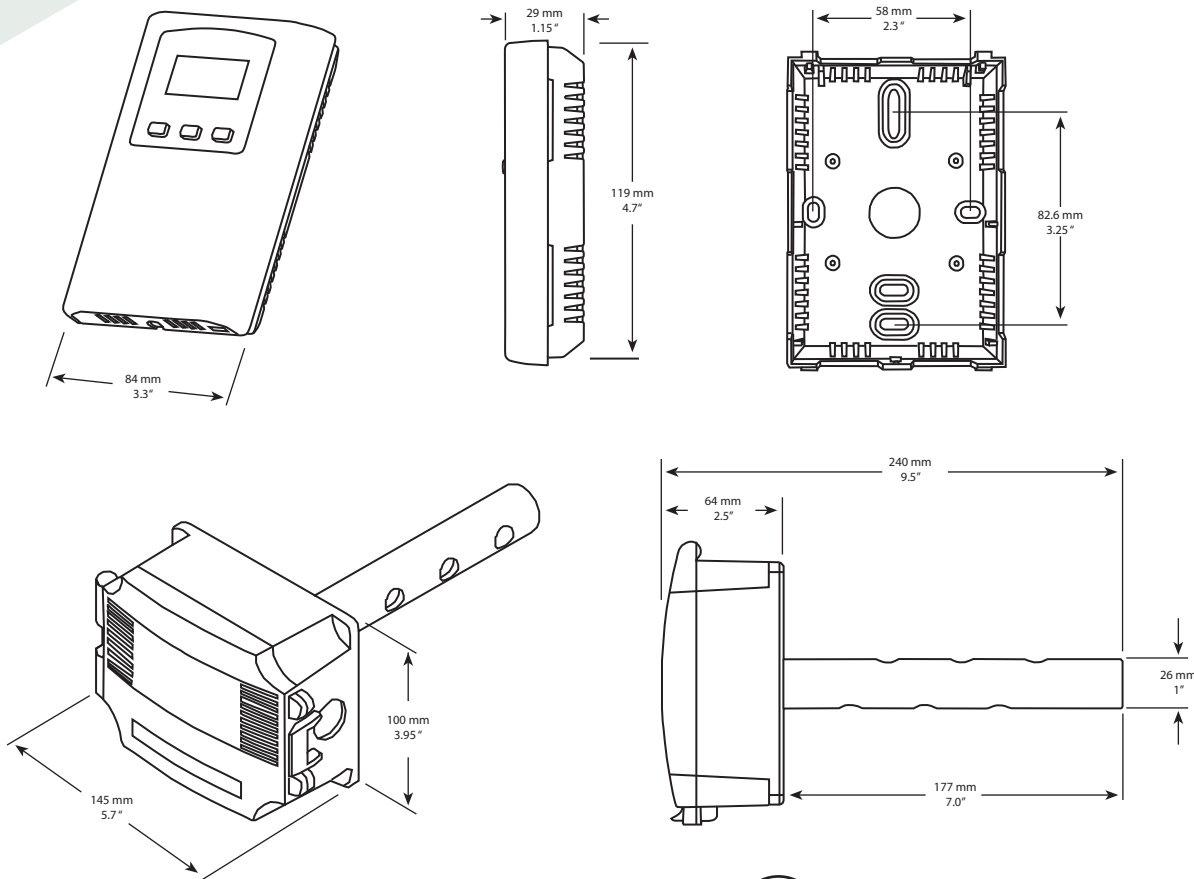

Greystone Energy Systems Inc.
 150 English Drive, Moncton,
 New Brunswick, Canada E1E 4G7
 (506) 853-3057 Fax: (506) 853-6014
 North America: 1-800-561-5611
 e-mail: mail@greystoneenergy.com
 web site: www.greystoneenergy.com



Greystone Energy Systems Inc. is one of North America's largest ISO registered manufacturers of HVAC/R sensors and transmitters for Building Automation Management Systems.

We have conscientiously established a worldwide reputation as an industry leader by maintaining leading-edge design technology, prompt technical support, and a commitment to on-time deliveries. We take pride in our Quality Management System which is ISO 9001 certified, assuring our customers of consistent product reliability.

GREYSTONE HAS AN ISO 9001 REGISTERED QUALITY SYSTEM