



LAING THERMOTECH SERIES

Hot Water Recirculation Pumps

EFFICIENCY UNLEASHED. HOT WATER INSTANTLY!

CIRCULATORS E5 Brass Pumps

Potable Hot Water Recirculation Pumps - Whole House

Description

E Series circulators are energy efficient circulators using permanent magnet, ECM (electronically commutated motor) technology. The E Series circulators are designed specifically for potable water applications. These circulators are lead-free* and come with a variety of options including a temperature sensor, various body styles, assembled with electrical cord and plug. Timer sold as an accessory.

Materials of Construction	
Pump Body:	Lead-Free* Brass
O-Ring:	EPDM or Viton
Bearing:	Carbon/Alumina Ceramic
Impeller:	Nylon/PPO
Motor:	High Efficiency ECM
All Other Wetted Parts:	Type 316 Stainless Steel, Shaft-less and seal-less construction

Operating Data Pump	
Maximum Working Pressure:	150 PSI (10.3 Bar)
Maximum Working Temperature:	203°F (95°C)
Minimum Working Temperature:	50°F (10°C)

Motor

- ECM Spherical Motor
- 10-28 Watts Power Consumption
- Automatic Overload Protection
- Low in-rush current

Pump Curves

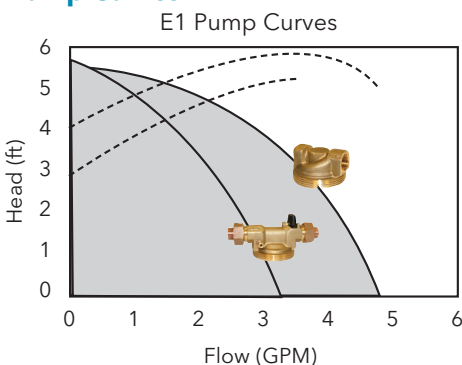

Adjustable Speed Switch (Models Without Temp Sensor)

- Infinitely variable-speed switch to manually adjust motor speed.

Adjustable Temperature Sensor (Fixed Speed Only)

- Adjustable Set Point from 68°F to 158°F (20°C to 70°C)
- Turns circulator OFF when water temperature reaches set point
- Turns circulator ON when water temperature is 10°F (6°C) below set point

Connections

- 1/2" UltraCirc with Ball & Check Valve
- 1/2" Sweat
- 1/2" FNPT Threaded

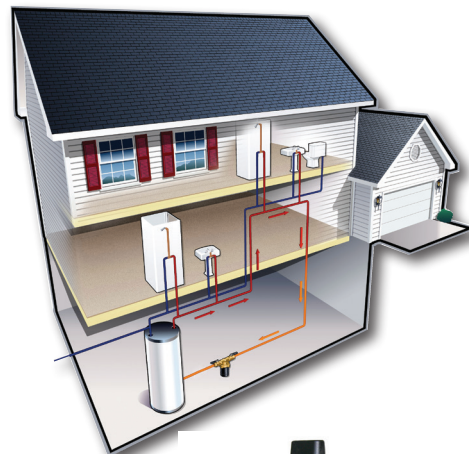

E1/E3 Timer

E1/E3

UltraCirc Pump Housing (Union with Ball & Check Valve)

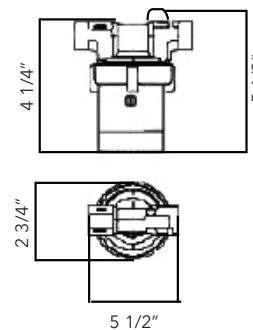

— UltraCirc Housing Flow - - - - UltraCirc Housing Energy Consumption
 — NPT/Sweat Housing Flow - - - - NPT/Sweat Housing Energy Consumption

Part Number	Model Number	Materials	Connection		Adjustable Speed	Adjustable Thermostat	Plug
			Size	Type			
60A0G1005	E1-BCSVNNNN-01	Lead-Free Brass	1/2"	Sweat	•		
60A0G1006	E1-BCSVNNNNW-01	Lead-Free Brass	1/2"	Sweat	•		•
60A0G3002	E1-BCSFNRNW-01	Lead-Free Brass	1/2"	Sweat		•	•
60A0G1007	E1-BCTVNNNN-01	Lead-Free Brass	1/2"	Thread	•		
60A0G1008	E1-BCTVNNNNW-01	Lead-Free Brass	1/2"	Thread	•		•
60A0G3003	E1-BCTFNRRW-01	Lead-Free Brass	1/2"	Thread		•	•
60A0G1004	E1-BCUVNNNNW-01	Lead-Free Brass	1/2"	Union	•		•
60A0G3001	E1-BCUFNRNW-01	Lead-Free Brass	1/2"	Union		•	•
60A0G1002	E3-BCSVNNNNW-01	Lead-Free Brass	1/2"	Sweat	•		•
60A0G1003	E3-BCTVNNNNW-01	Lead-Free Brass	1/2"	Thread	•		•
60A0G1001	E3-BCUVNNNNW-01	Lead-Free Brass	1/2"	Union	•		•
60AAGT001	Plug-In Timer for E1/E3						

Standard Pump Housing (Sweat & Threaded)

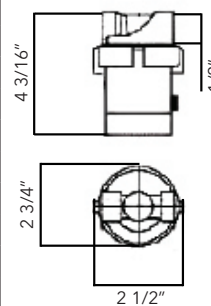

CIRCULATORS autocirc®

Potable Hot Water Recirculation Pumps - Undersink Description

autocirc® circulators are energy efficient using permanent magnet, ECM (electronically commutated motor) technology. The autocirc circulators are designed specifically for standard water heaters. These circulators are lead-free* and are assembled with a timer, cord and plug. No recirculation line is required.



E1-BCANRT1W-06

E1-BCANCT1W-06

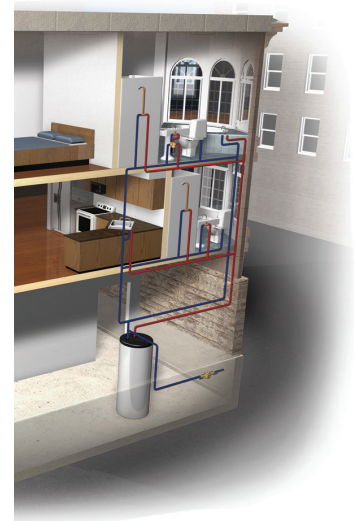

Materials of Construction	
Pump Body:	Lead-Free* Brass
O-Ring:	EPDM
Bearing:	Carbon/Ceramic
Impeller:	Nylon/PPO
Motor:	High Efficiency ECM
All Other Wetted Parts:	Type 316 Stainless Steel, Shaft-less and seal-less construction

Motor

- ECM Spherical Motor
- 115 Volt 60 Hz, 1 Phase
- 14 Watts Power Consumption
- Automatic Overload Protection
- Low in-rush current

Operating Data Pump	
Maximum Working Pressure:	145 PSI (10 Bar)
Maximum Working Temperature:	203°F (95°C)
Minimum Working Temperature:	50°F (10°C)

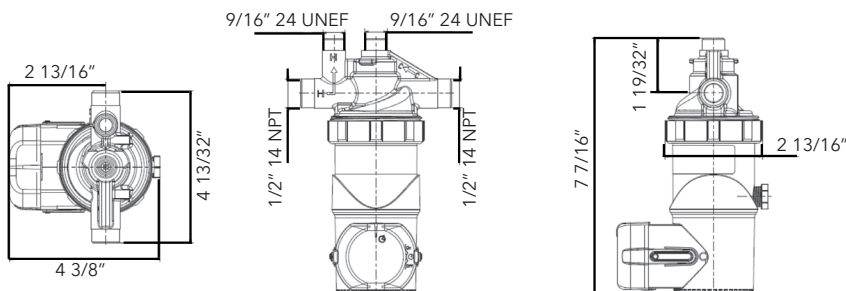

Part Number	Model Number	Description
60A0G6001	E1-BCAFNCTW-01	Lead Free Brass* autocirc® 1/2" Fixed Thermostat with Timer
60A0G6002	E1-BCAFNRTW-01	Lead Free Brass* autocirc® 1/2" Adjustable "ON" Thermostat with Timer

CIRCULATORS ACT-E10

Potable Hot Water Recirculation Pumps - Undersink Description

The ACT-E10 lead-free* pump was designed with highly efficient electronically commutated permanent magnet motor (ECM/PM technology) specifically for potable water systems. This unique design is perfect for retrofits and systems with tankless water heaters. No recirculation line is required.



E10-BCANCT1W-23

Materials of Construction	
Pump Body:	Lead-Free* Brass
O-Ring:	EPDM
Bearing:	Carbon/Ceramic
Impeller:	Nylon/PPO
Motor:	High Efficiency ECM
All Other Wetted Parts:	Type 316 Stainless Steel, Shaft-less and seal-less construction

Motor

- ECM Spherical Motor
- 115 Volt 60 Hz, 1 Phase
- 60 Watts Power Consumption
- Automatic Overload Protection
- Low in-rush current

Operating Data Pump	
Maximum Working Pressure:	145 PSI (10 Bar)
Maximum Working Temperature:	203°F (95°C)
Minimum Working Temperature:	50°F (10°C)

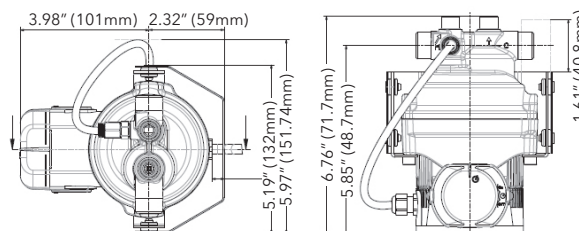

Part Number	Model Number	Description	Weight
6050E7000	E10-BCANCT1W-23	Lead-Free Brass autocirc 1/2" Fixed Thermostat with Timer	6.50 lbs.

*CSA certified to NSF/ANSI 372 that product contains less than 0.25% lead content by weight on wetted surface.

CIRCULATORS ACT-4

Potable Hot Water Recirculation Kit

Description

The ACT-4 is a potable hot water recirculation kit (a pump and valve combination) for instant supply of hot water supply throughout the entire house.

The ACT-4 pump is installed on the supply side of the hot water source and the mixing valve under the sink farthest away from the hot water source. The pump and valve are in constant wireless communication. No recirculation line is required.

How it Works

The desired water temperature at the valve is set directly on the pump with the thermostat dial. The water temperature is constantly checked by the valve and the temperature values are sent to the pump. At approximately 5°F below the desired water temperature, the pump will begin to circulate hot water. This circulation will open the valve for hot water to cross into the cold water line, which creates a return loop back to the hot water source. When the desired temperature is reached, the pump will stop circulating. This is to prevent continuous circulation.

An Optional Push Button / Signal Repeater

A wireless device to provide instant hot water with a push of a button. The push button device will override the timer operation and activate the pump to circulate hot water until the desired temperature is met at the valve. This device also functions as a signal repeater when the pump and valve have a weak signal due to distance or interference.



Operating Data Pump

Maximum Operating Temperature:	203°F (95°C)
Maximum Operating Pressure:	145 PSI (10 Bar)
Power Supply:	115 Volts, 60 HZ, 1 Phase
Power Consumption:	20 Watts
Operating Noise Level:	30 dB
Batteries:	2 AA Alkaline
Estimated Battery Life:	2 Years
Maximum Transmitter Range:	150 ft

Materials of Construction

Circulator Pump Body	Lead-Free* Brass
Seals:	EPDM
Impeller:	Nylon/PPO
Internals:	316 Stainless Steel
Paired Mixing Valve Body:	Lead-Free* Brass
Springs:	Stainless Steel
Valve Insert:	Acetal Plastic
Transmitter Housing:	ABS Plastic

* CSA certified to NSF/ANSI 372 that product contains less than 0.25% lead content by weight on wetted surface.

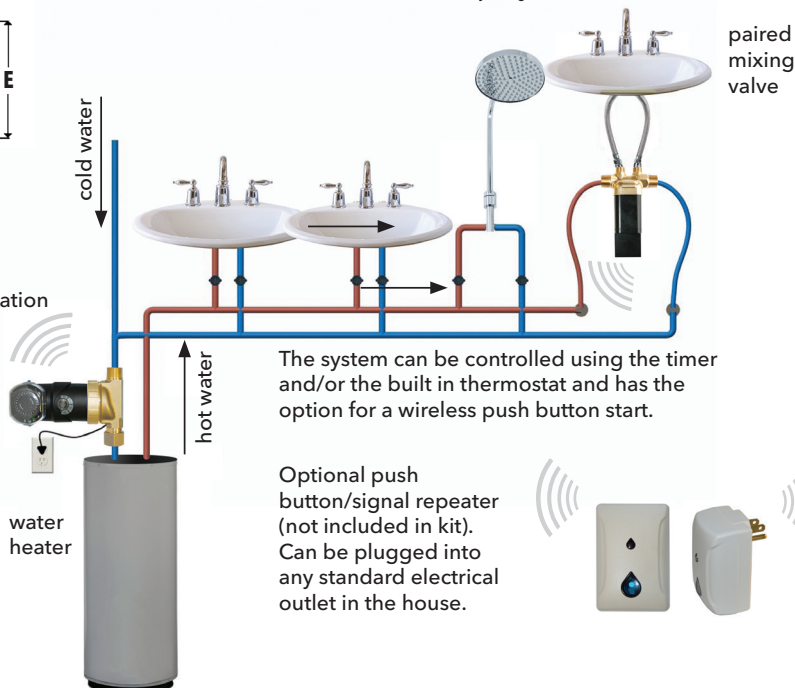
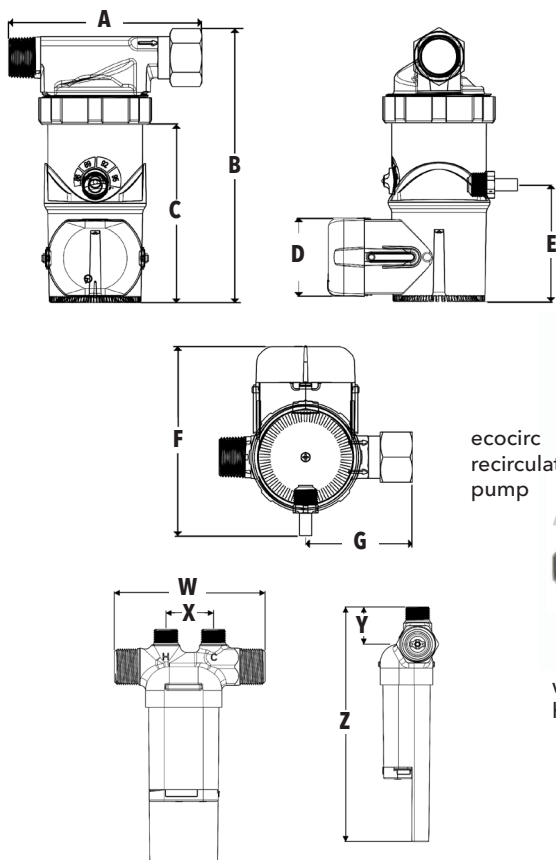

Part Number	Model Number	Connection	Dimension Inches (mm)											Shipping Weight lbs. (kg)
			A	B	C	D	E	F	G	W	X	Y	Z	
6050E4050	ACT-4 Recirculation Kit	Pump: 3/4" M/F NPT Valve: 1/2" MNPT x 3/8" compression	4.84 (123)	6.87 (174.6)	4.47 (113.5)	1.97 (50.1)	2.93 (74.4)	4.74 (120.5)	2.68 (68)	3.5 (89)	1.1 (28)	0.87 (22)	5.45 (138.5)	3.9 (1.8)
6099E1550	Push Button/Signal Repeater													

CIRCULATORS D5 Solar Pump

Spherical Motor Pump

Application

- The D5 solar pump can be used for most circulation pump applications without connection to the power grid with direct connection to a photovoltaic panel.
- This pump is perfect for single family home thermal solar systems or any circulation pump application where conventional power is not available, on closed loop systems

Design

- The only moving part is a hemispherical rotor/impeller unit which sits on an ultra-hard, wear-resistant ceramic ball.
- There are no conventional shaft bearings or seals eliminating bearing noise and seal leaks.
- This pump is robust and has an estimated service life in excess of 50,000 hours.
- All parts exposed to the fluid are completely corrosion resistant.

Soft Start-up

- When the photovoltaic panel provides sufficient power, the pump goes through the alignment phase by turning the rotor into the position required for start-up.
- The processor then waits until the capacitor is sufficiently charged.
- This enables a start-up with minimal power (less than one watt).

Over-temperature Safety Device

- The D5 solar pump comes with an integrated over-temperature safety device which shuts off the pump electronics when reaching temperatures over 230°F.
- After reaching a critical temperature 203°F the pump will lower its speed automatically in order to avoid a total shutdown.

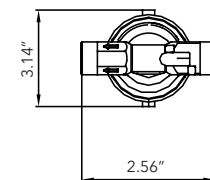
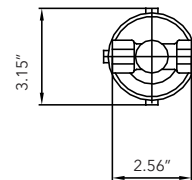
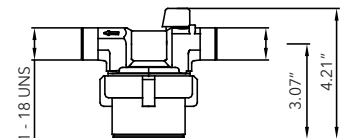
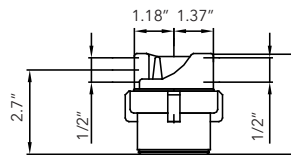
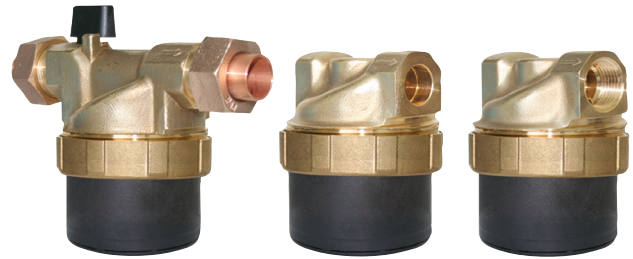

D5 Solar 710B and 720B

D5 Solar 090B

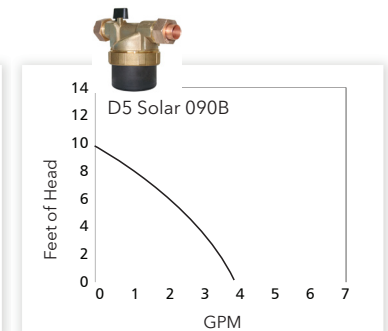
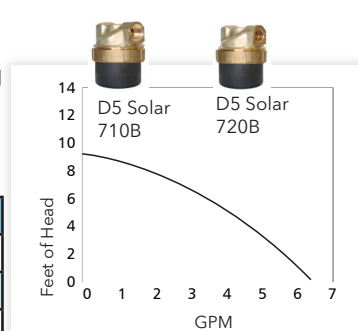

Materials of Construction	
Pump Body:	Lead-Free* Brass
O-Ring:	EPDM
Bearing:	Carbon/Alumina Ceramic
Impeller:	PPO
Motor:	High Efficiency ECM
All Other Wetted Parts:	Type 316 Stainless Steel, Shaft-less and seal-less construction

Technical Data	
Motor Design:	Electronically commutated spherical motor with permanent magnet rotor/impeller
Voltage:	12 - 24 Volt
Maxium System Temperature:	203°F (95°C)
Maxium Pressure:	150 PSI
Power Consumption*:	Min. start-up power consumption less than 1 Watt, max. power consumption 22 Watts
Current Draw:	0.25 - 1.46 A
Acceptable Media:	Potable hot water recirculation, heating water, water/glycol mixtures, other media on request**
Environment:	IP 42
Insulation Class:	Class F

Available Models

* Power consumption and start may vary in different installations. **Please check pump performance with more than 20% glycol.

Part Number	Model	Description	Weight
LMB15107992	D5 Solar / 720B	Lead-Free Brass* Solar Circulator 1/2" Sweat	2 lbs.
LMB15107993	D5 Solar / 710B	Lead-Free Brass* Solar Circulator 1/2" NPT	2 lbs.
LMB15107995	D5 Solar / 090B	Lead-Free Brass* Solar Circulator 1/2" Union Sweat**	2 lbs.

*CSA certified to NSF/ANSI 372 that product contains less than 0.25% lead content by weight on wetted surface.

** Built-in ball check valve and purge valve.

CIRCULATORS D5 Brass Pumps DC Powered Pump

Application

- D5 pumps (basic, vario, strong and solar) can be used in a wide variety of DC applications where a highly efficient circulation pump is required.
- D5 pumps are used in a wide variety of applications such as medical devices, electronics cooling, chillers, laser cooling, RV hot water systems, battery cooling, and fuel cells.

Design

- The single moving part in a spherical motor is a hemispherical rotor/impeller unit. The rotor/ impeller rides on an ultra-hard, wear-resistant ceramic ball.
- There are no conventional shaft bearings or seals. Eliminating the possibility of bearing-play and a potential leak path.
- Provide an exceptionally long service life in excess of 50,000 hours.
- Maintenance is not necessary under normal conditions. Even after lengthy shut down periods a reliable start-up is virtually guaranteed.
- Parts exposed to the fluid are completely corrosion resistant even with aggressive fluids.

Speed Controller

- Easily adjusts by turning a dial in the pump end. It can be adjusted to vary the hydraulic performance and/or the electrical power consumption.
- Regardless of the setting, the pump always starts with maximum torque. This ensures a reliable start even at the lowest speed.

Integrated Over-temperature Protection

- Each pump has an integrated over-temperature safety device that shuts the pumps electronics off when reaching the temperature limit of +203°F.
- If the over-temperature safety device is activated the pump will restart automatically after the pump has cooled completely.



D5 Brass

D5 710B/ D5 720B

D5 090B

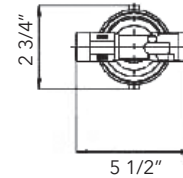
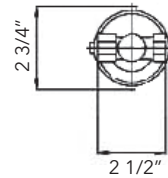
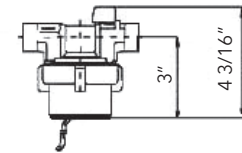
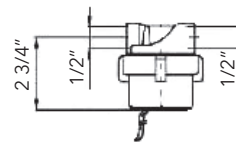

Technical Data	
Motor Design:	Electronically commutated spherical motor with permanent magnet rotor/impeller
Voltage:	8 - 25 Volt
Power Consumption:	See pump curves
Current Draw:	D5 basic and vario: 0.25 - 1.46 A D5 strong: 0.13 - 2.1 A
Acceptable Media:	Hot or cold water, water/glycol mixtures, and other non-flammable media on request. When using more than 20% glycol, pump performance may decrease.
Insulation Class :	IP 42 / Class F
Maximum system Pressure:	150 PSI - 1.0 MPa (10 bar) for pumps with brass housings 50 PSI - 0.35 MPa (3.5 bar) for pumps with plastic housing
Maximum system Temperature:	-10°F to +203°F (-10°C to + 95°C) for pumps with brass housing (non-freezing) +32°F to +140°F (+/- 0°C to + 60°C) for pumps with plastic housing (non-freezing)
Weight :	1.54 lbs. (0.7kg) for pumps with brass housing 77 lbs. (0.35kg) for pumps with plastic housing

Available Models

Model	Connection	Power Consumption	Housing Material
D5 710 B	1/2" female thread	"8-25 Volt DC 3-35 Watts, 0.30-1.50 Amps D5 strong: 3-55 Watts, 0.13-2.1 Amps"	Brass
D5 720 B	1/2" sweat		
D5 090 B	1/2" sweat union w/check valve		

D5 Pump Curves - Brass

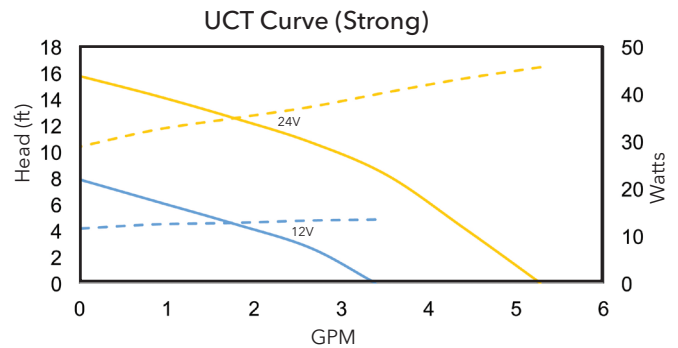
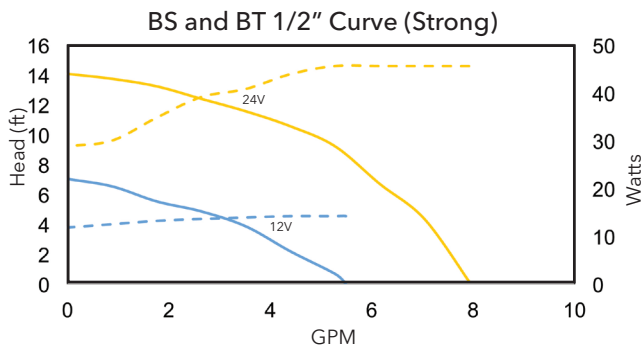
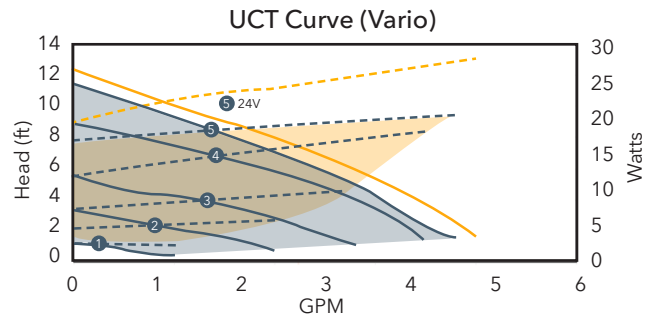
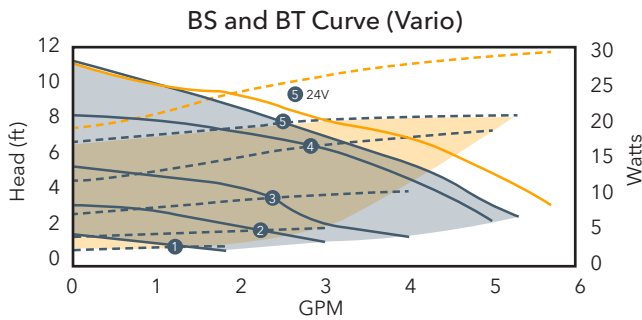

Note: Pump curves vary depending on pump housing, speed control setting and supply voltage.

The **D5 Vario** will vary based on the speed control setting. The curves in blue ⑤ ④ ③ ② ① are for supply voltage range 12-23 volts.

For maximum performance for the **D5 Vario** (shown in yellow), the supply voltage must be 24 volts and speed control setting at maximum. The **D5 Basic** have a fixed performance curve for a supply voltage range 12-24 volts, the curve is shown as ④ setting of the Vario charts. The **D5 Strong** will vary based on the supply voltage. The maximum performance is shown in yellow with 24 volts supply and the 12 volts supply performance curve is shown in blue.

CONTROLS E1/E3 SERIES TIMER

Description

To increase the overall efficiency of a domestic hot water recirculating system and to reduce water wasted while waiting for hot water, the E1/E3 Timer can be installed on all E1/E3 pumps. The timer is easily installed by removing the motor end cap, plugging in the timer and setting the timer schedule without any wiring. The timer can be used in 3-different selections: ON, OFF and TIMER. The ON selection operates the pump continuously, the OFF selection turns the pump OFF and the TIMER selection (depicted by a clock on the timer) turns the pump on when programmed.

Operational Limits	
Pump Body:	Internally powered by the E1/E3 circulating pump
Minimum Switch Interval:	30 minutes
Run Modes:	ON (Continuous), OFF (Off at all times) and TIMER (run at programmed intervals)

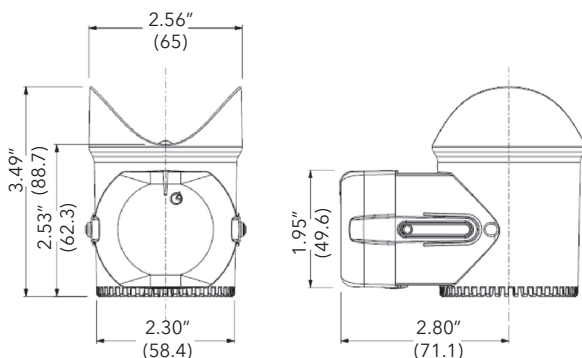

**E1/E3 Series Timer
(Part No. 60AAGT001)**

Pump not included

Xylem |'zīləm|

- 1) The tissue in plants that brings water upward from the roots;
- 2) a leading global water technology company.

We're a global team unified in a common purpose: creating advanced technology solutions to the world's water challenges. Developing new technologies that will improve the way water is used, conserved, and re-used in the future is central to our work. Our products and services move, treat, analyze, monitor and return water to the environment, in public utility, industrial, residential and commercial building services settings. Xylem also provides a leading portfolio of smart metering, network technologies and advanced analytics solutions for water, electric and gas utilities. In more than 150 countries, we have strong, long-standing relationships with customers who know us for our powerful combination of leading product brands and applications expertise with a strong focus on developing comprehensive, sustainable solutions.

For more information on how Xylem can help you, go to www.xylem.com

**EFFICIENCY
UNLEASHED
HOT WATER
INSTANTLY**



Xylem Inc.
2881 East Bayard Street Ext., Suite A
Seneca Falls, NY 13148
Phone: (866) 325-4210
Fax: (888) 322-5877
www.xylem.com/goulds

Xylem and Laing Thermotech are trademarks of Xylem Inc. or one of its subsidiaries. Goulds is a registered trademark of ITT Manufacturing Enterprises LLC and is used under license. All other trademarks or registered trademarks are property of their respective owners.

© 2023 Xylem Inc. GWT-LAINGCIRC-120057 - R2 September 2023

Learn more about
Laing thermotech series

