

Laing Thermotech Series Autocirc® Instant Hot Water Pump Model: ACT E10

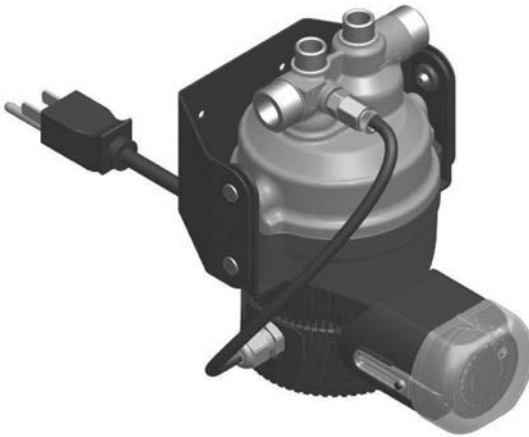

Please read this manual carefully before attempting to install, operate or maintain the product described. Failure to comply with the information provided in this manual could result in personal injury and/or property damage. Retain this manual for future reference.

INSTALLER: PLEASE LEAVE THIS MANUAL FOR THE OWNER'S USE.

How the Autocirc Pump System Works

The Autocirc® pump is installed under the sink farthest from the water heater, where hot water takes longest to arrive.

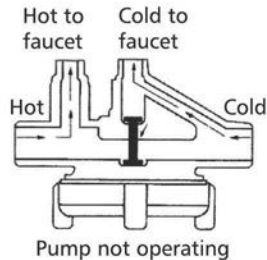
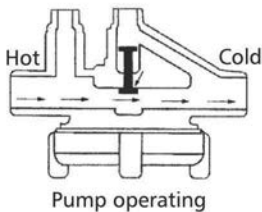

Model with fixed thermostat -

- A built-in temperature sensor automatically turns the pump ON when the water temperature in the hot water supply line cools down to 89.6°F (32°C). The pump then moves the cool water in the hot water supply line into the cold water supply line.
- Autocirc Pump turns OFF automatically when water temperature reaches 95°F (35°C), ensuring instant availability of warm water with hot water only seconds behind.
- When the pump is OFF, a built-in auto closure device (check valve) prevents hot and cold water mixing.
- Hot water will also be instantly available at all other fixtures between the water heater and the sink under which the Autocirc pump is installed.

The Autocirc

Pump System - Typical Schematic Diagram

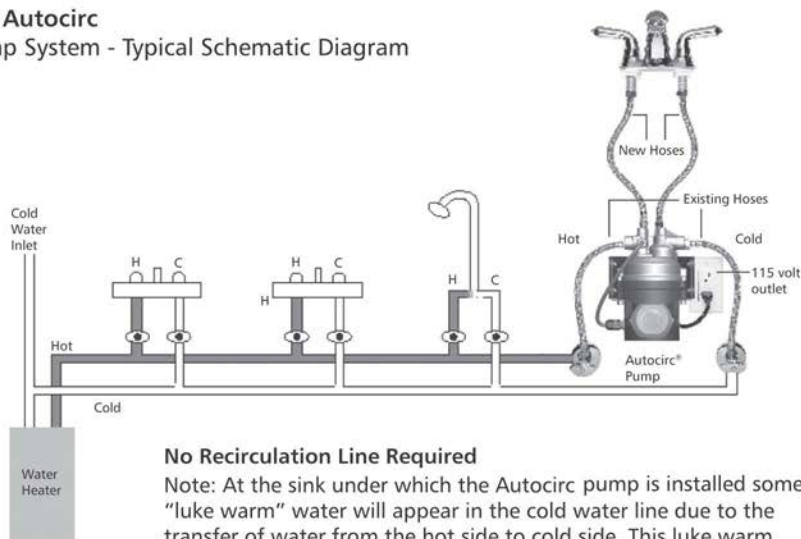

No Recirculation Line Required

Note: At the sink under which the Autocirc pump is installed some "luke warm" water will appear in the cold water line due to the transfer of water from the hot side to cold side. This luke warm water will, however, disappear in a short time (4-5 seconds) once the cold faucet/taps are opened.

Autocirc® Technical Data

Motor:	115 Volt, 1 Phase, 60Hz 60 Watts
Unit Weight:	5.5 lbs (2.35kg)
Overall Dimensions:	7" height (17.8cm) 6" width (15.2cm)



Australia

This pump must be installed in accordance with AS3500.

U.L. Caution

This pump has been tested using water only. Its suitability for use with liquids other than water is the end user's responsibility.

Preparation for Installation:

Assemble the parts and tools required:

1. Open and inspect Autocirc pump package.
2. Autocirc pump package includes the pump with a built-in timer, a 6ft. cord, and wall mounting bracket.
3. Two stainless steel flexible hoses (1/2" x 3/8") - length as required. (sold separately)
4. Adjustable wrench and screwdriver.
5. Select the sink under which the Autocirc pump is to be located (the sink where hot water takes longest to arrive).



CAUTION: PROPERTY DAMAGE HAZARD

It is not advisable to install circulators in an attic or upper floor over finished living space. If the circulator must be installed over head, or over expensive equipment, provide adequate drainage in the event of leakage. Failure to follow these instructions could result in property damage.

Installation

Step 1

If not already available, install a 115 Volt/ 60Hz outlet within six (6) feet of the installation site (the faucet/tap farthest from the water heater), as the Autocirc is supplied with a 6 ft. long, grounded cord (see Fig. 1).

Step 2

Autocirc pump and mounting bracket come preassembled. Remove mounting bracket from Autocirc by carefully sliding the mounting bracket off the (4) supporting pins on the Autocirc pump body. Fasten the mounting to the wall under the sink using the wall bracket provided in the Autocirc kit. Mount Autocirc pump into position by aligning and securing mounting bracket to the (4) support pins. Be sure the pump timer is turned toward the front and is accessible for setting and changing the time (see Fig. 2). The pump must be installed only in a vertical position as shown.



CAUTION: Do Not fasten pump to a thin wood panel wall as this might create a vibration noise when the pump is operating.

Step 3

Close the under sink hot and cold water riser shut-off valves and open the hot and cold water faucets/taps to relieve the water pressure. Close the water faucets/taps after pressure has bled from the lines.

Note: in some older homes, the riser shut-off valves may be difficult to shut off completely. If this is the case turn the water off at the main water inlet valve to the house.



Figure 1



Figure 2



Figure 3

Remove the existing flexible line connection to the hot and cold water faucet/tap threaded nipples (see Fig. 3). (**TIP: Mark the hot and cold water flexible lines to easily identify them.**)

Note: If necessary, replace the existing flexible hoses with new stainless steel braided flexible hoses in the lengths required.

Step 4

Screw on the two existing 1/2" hose connections to the corresponding hot and cold sides of the pump housing (see Fig. 4). Be sure not to "kink" these existing hose lines during bending which may prevent adequate flow and/or cause the valves to break.



Figure 4

Note: It is recommended that the rubber washers in the hose connections be inspected to ensure they are in reusable condition. If not, they should be replaced.

Step 5

Screw on the 3/8" end of the purchased flexible hoses to the 3/8" connections on the pump housing. Screw on the 1/2" end of these same two hoses to the underside of the hot and cold water faucets/taps making sure to match the hot and cold sides marked on the pump housing with the corresponding faucet/tap. Be sure the hot side connection hose is attached to the hot water faucet/tap and the cold water side connection is attached to the cold water faucet/tap. Be sure the hoses used are long enough to allow the pump to be positioned as originally planned. (see Fig. 5)



Figure 5

Step 6

Be sure the screw ring attaching the motor to the pump housing is securely hand tightened. Do not over tighten the screw ring. Open the faucet/tap hot and cold riser shut off valves to insure there are no water leaks at any connections.



CAUTION: Fasten screw ring until tight to prevent leakage.

Step 7

Plug the pump cord into the wall outlet and start up the pump system (see next page).

Note: The above installation method applies to most situations where faucets/taps are connected to the hot and cold water supply lines with braided flexible hose/shut off valve arrangements. If the under sink arrangement is different (i.e. the risers are hard copper or plastic), then other parts may be required for the installation.



Figure 6

Autocirc Start Up Procedures

Timer Controlled Operation

If timer controlled operation is desired, the timer may be programmed to allow the Autocirc to operate during the hours desired (i.e. "ON" from 7:00 a.m. to 9:00 p.m. and "OFF" from 9:00 p.m. to 7:00 a.m.) as follows:

- Open timer cover and rotate the dial clockwise until the correct time is aligned with the pointer at the top (12 o'clock position) of the dial.
- Automatic Operation: PULL the tabs Upward on timer for the desired operating period of time. Example: If the desired operating time is 7:00 a.m. to 9:00 a.m., all tabs should be Pulled out between 7 and 9. NOTE: The timer may be set for multiple operating periods of time.
- Slide the switch bar to  "On".

The timer mode will provide the most cost effective method of operation and can be programmed to run only during the time periods when hot water is most frequently required. Even during controlled timer operation, the Autocirc will only turn on when the built-in thermostat senses that additional hot water is required at the point of installation.

Thermostat Operation Mode

To operate the Autocirc "thermostatically" without the timer, slide the switch to the "ON" position. In the "ON" position the pump runs "automatically", whenever the built-in thermostat senses the requirement for hot water. In the "OFF" position the pump does not operate at any time.

In either the "ON" or "OFF" position, the timer dial continues to rotate through the 24 hour sequence keeping accurate time. When timer controlled operation is resumed, the Autocirc will operate during the previously programmed time sequence(s).

Note: The Autocirc will most likely start running immediately and turn off after a few minutes once hot water reaches the faucet. It will then continue cycling "ON" and "OFF" as required during the programmed sequence of operation. Do not be concerned if the pump does not begin running immediately after the pump is plugged in. This just means that there is already hot water at the hot water faucet and the pump will turn on "automatically" when the hot water line cools down.

NOTE: The Autocirc start thermostat is pre adjusted to 91°F (33°C) at the factory, and will provide the best pump performance at this setting.

Maintenance and Trouble Shooting

The pump does not turn on

- Ensure the timer slide switch is set to the "ON" position or the "⏻" position, that the timer clock is programmed to allow operation; and that there is power to the outlet.
- If the pump is installed under a kitchen sink, make sure the outlet is not controlled by a wall switch (i.e., garbage disposal).

The pump is noisy when on

- Turn off the Autocirc pump. Turn on the hot and cold faucets/taps to be sure all air is purged from the system.
- If the noise continues, unplug the pump and turn off the faucet/taps shut-off valves. Remove the pump from the wall bracket, loosen the screw ring to separate motor from the pump housing and check for any foreign matter in the rotor cavity. Also ensure the rotor is properly set on the motor bearing by pushing down on the rotor.
- If a noise occurs when the pump turns off it is likely to be "water hammer" that results from the closure of the built-in valve. In this situation, water hammer arresters may be installed on the hot and cold lines.

Hot water is not instantly available at all my faucets/taps

- Instant hot water will be available at all the hot water faucets/taps on the main plumbing line between the water heater and the faucet/taps under which the Autocirc system is installed. Hot water faucets/taps that are "branched" off this main hot water supply line will take longer for the hot water to arrive, however, usually faster than before installing the Autocirc.

I am away from my home for extended periods of time (2 weeks or more)

- You may chose to turn the system off (slide the timer switch to the "OFF" position) as there is no need to maintain hot water in the supply line when no one is home to enjoy this convenience. When returning home, prior to turning on the system, we recommend that you turn on the hot and cold faucets/taps at the sink where the Autocirc system is installed until all air is purged from the dormant system and the water flows smoothly from the faucets/taps. Then slide the timer switch back to either the "ON" or "⏻" position.

Warranty claim

Xylem products are high-quality products with expected reliable operation and long life. However, should the need arise for a warranty claim, then contact your local sales and service representative.

Safety Requirements

Mechanical Safety



WARNING: - Excessive System Pressure Hazard - The maximum working pressure of the pump is listed on the nameplate - **Do Not Exceed This Pressure.** Failure to follow these instructions could result in serious personal injury, death and/or property damage.



WARNING: - Excessive Pressure Hazard Volumetric Expansion - The heating of water and other fluids causes volumetric expansion. The associated forces may cause failure of system components and the release of high temperature fluids. This can be prevented by installing properly sized and located compression tanks and pressure relief valves. Failure to follow these instructions could result in serious personal injury, death and/or property damage.

Thermal Safety



WARNING: - Extreme Temperature Hazard - If the pump, motor or piping are operating at extremely high or low temperature, guarding or insulation is required. Failure to follow these instructions could result in serious personal injury, death and/or property damage.

Electrical Safety



WARNING: - Electrical Shock Hazard - Electrical connections are to be made by a qualified electrician in accordance with all applicable codes, ordinances and good practices. Failure to follow these instructions could result in serious personal injury, death and/or property damage.



WARNING: - Electrical Grounding Hazard - Adequate electrical grounding is required for the safe operation of Laing pumps. Ground the pump back to the service using a copper conductor at least the size of the circuit connectors supplying the pump. Connect the ground wire to the ground terminal in the wiring compartment. Failure to follow these instructions could result in serious personal injury, death and/or property damage.



WARNING: - Risk of Electric Shock - If this pump is supplied with a grounding conductor and grounding-type attachment plug, to reduce the risk of electric shock, be certain that it is connected only to a properly grounded, grounding-type receptacle.



WARNING: - Risk of Electric Shock - Do not install this pump in swimming pool or marine areas. Failure to follow these instructions could result in serious personal injury, death and/or property damage.

Removal of Pump From Existing System For Replacement



WARNING: - Electrical Shock Hazard - Disconnect and lockout the power before servicing. Failure to follow these instructions could result in serious personal injury, death and/or property damage.

1. Close the valves on the suction and discharge sides of the pump. (if no valves have been installed, it may be necessary to drain the system.)
2. Disconnect the electrical supply lines to the pump.



WARNING: - Hot Water Hazard - Before draining the system, allow water to cool to at least 100F, open the drain valve (take precautions against water damage) and leave the drain valve open until servicing is complete. Failure to follow these instructions could result in serious personal injury, death and/or property damage.



WARNING: - Electrical Shock Hazard - Be certain the electrical power is not present at the motor leads before continuing. Failure to follow these instructions could result in serious personal injury, death and/or property damage.



WARNING: - High Pressure Hazard - Pressure may be present in the pump body. This pressure can be relieved by loosening the flange bolts and shifting the pump assembly slightly to allow the pressurized water to escape. Failure to follow these instructions could result in serious personal injury and death.

Goulds Water Technology Branded Products

Limited Consumer Warranty

For goods sold for personal, family, or household. Seller warrants the goods purchased hereunder (with the exception of membranes, seals, gaskets, elastomer materials, coatings, and other "wear parts" or consumables all of which are not warranted) will be free from defects in material and workmanship for a period of one (1) year from the date of installation or twenty-four (24) months from the date of manufacture (which date of manufacture shall not be greater than thirty (30) days after receipt of notice that the goods are ready to return) whichever shall occur first.

Except as otherwise required by law, Seller shall, at its option and at no cost to Buyer, either repair or replace any product which fails to conform to the Warranty provided Buyer gives written notice to Seller of any defects in material or workmanship within ten (10) days of the date when any defects or non-conformance are first manifest. Under either repair or replacement option, Seller shall not be obligated to remove or pay for the removal of the defective product or install or pay for the installation of the replaced or repaired product and Buyer shall be responsible for all other costs, including, but not limited to, service costs, shipping fees, and expenses. Seller shall have sole discretion as to the method or means of repair or replacement. Buyer's failure to comply with Seller's repair or replacement directions shall terminate Seller's obligations under the Warranty are warranted only for the balance of the warranty period on the parts that were repaired or replaced. The Warranty is conditioned on Buyer giving written notice to Seller of any defects in material or workmanship of warranted goods within ten (10) days of the date when any defects are first manifest.

Seller shall have no warranty obligations to Buyer with respect to any product that have been: (a) repaired by third parties other than Seller or without Seller's written approval; (b) subject to misuse, misapplication, neglect, alteration, accident, or physical damage; (c) used in a contrary to Seller's instructions for installations, operation, and maintenance; (d) damaged from ordinary wear and tear, corrosion, or chemical attack; (e) damaged due to abnormal conditions, vibration, failure to properly prime, or operation without flow; (f) damaged due to a defective power supply or improper electrical protection; or (g) damaged resulting from the use of accessory equipment not sold or approved by Seller. In any case of products not manufactured by Sellers, there is no warranty from Seller; however, Seller will extend to Buyer any warranty received from Seller's supplier of such products.

THE FOREGOING WARRANTY IS PROVIDED IN PLACE OF ALL OTHER EXPRESS WARRANTIES. ALL IMPLIED WARRANTIES, INCLUDING BUT NOT LIMITED TO THE IMPLIED WARRANTIES OF MERCHANTABILITY AND FITNESS FOR A PARTICULAR PURPOSE, ARE LIMITED TO ONE (1) YEAR FROM THE DATE OF INSTALLATION OR TWENTY FOUR (24) MONTHS FROM THE PRODUCT DATE CODE, WHICHEVER SHALL OCCUR FIRST. EXCEPT AS OTHERWISE REQUIRED BY LAW, BUYER'S EXCLUSIVE REMEDY AND SELLER'S AGGREGATE LIABILITY FOR BREACH OF ANY OF THE FOREGOING WARRANTIES ARE LIMITED TO REPAIRING OR REPLACING THE PRODUCT AND SHALL IN ALL CASES BE LIMITED TO THE AMOUNT PAID BY THE BUYER FOR THE DEFECTIVE PRODUCT. IN NO EVENT SHALL SELLER BE LIABLE FOR ANY OTHER FORM OF DAMAGES, WHETHER TO LOSS OF PROFIT, LOSS OF ANTICIPATED SAVINGS OR REVENUE, LOSS OF INCOME, LOSS OF BUSINESS, LOSS OF PRODUCTION, LOSS OF OPPORTUNITY OR LOSS OF REPUTATION.

Some states do not allow limitations on how long an implied warranty lasts, so the above limitation may not apply to you. Some states do not allow the exclusion or limitation of incidental or consequential damages, so the above exclusions may not apply to you. This warranty gives you specific legal rights, and you may also have other rights which may vary from state to state.

To make a warranty claim, check first with the wholesaler or seller from whom you purchased the product or visit www.xylem.com for the name and location of the nearest representative providing warranty service.



Xylem Inc.
3878 S. Willow, Suite 104
Fresno, CA 93725
Tel: (559) 265-4730 (800) 554-6853
Fax: (559) 265-4740 (800) 453-7523
www.Laing-thermotech.com

Goulds is a registered trademark of Goulds Pumps, Inc. and is used under license.
© 2016 Xylem Inc. 671075184A June 2016