

# FQ Series

## Quiet Ventilating Fans



# FQ Series

## Quiet Ventilating Fans

FQ 80 / FQ 110



FQ 80FL / FQ 110FL

The FQ Series exhaust fans and fan lights provide remarkably quiet, energy efficient ventilation for baths, powder rooms and other areas. Super quiet with as low as <0.3 sones sound rating. Air performances of 80 to 110 CFM.

Fans are designed for intermittent or continuous operation to meet

**ASHRAE Standard 62.2.**

- Low profile grille fastened with torsion springs
- Thermal overload protection
- UL Listed for use over a tub/shower with a GFCI branch circuit wiring
- All models are HVI certified for sound and air performance
- 5 year warranty

### Specification Data

Model	Duct † size	Rated power W	Voltage / phase V / ~	0.1" P <sub>s</sub>	0.2" P <sub>s</sub>	0.3" P <sub>s</sub>	0.4" P <sub>s</sub>	Lamp power (Main / Night) W CFL	Sones	Shipping weight lbs
	inch			cfm						
FQ 80	4	25	120 / 1	80	68	56	43	-	<0.3	12
FQ 80FL	4	25	120 / 1	80	73	60	47	26 / 4	0.4	14
FQ 110	4	30	120 / 1	110	100	85	70	-	0.7	13
FQ 110FL	4	30	120 / 1	110	100	85	70	26 / 4	1.3	14

Performance shown is for installation type D - Ducted inlet, Ducted outlet. Performance is based on actual speed of test. Performance ratings do not include the effects of appurtenances in the airstream.  
 † Duct connections are 1/8" smaller than duct size.

### Dimensions

FQ 80FL / FQ 110FL

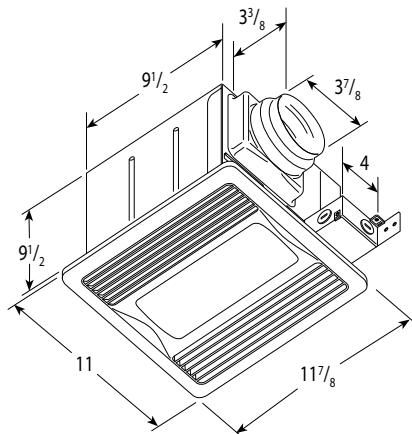

FQ 80 / FQ 110

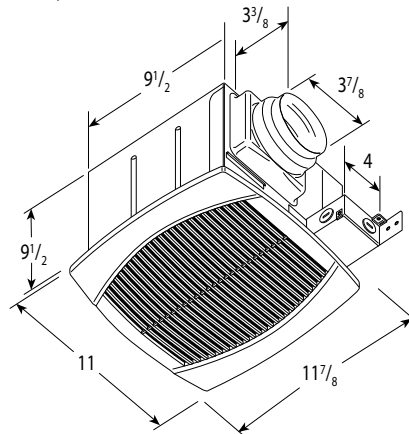

Dimensional information is in inches.

Unlit models are ENERGY STAR® qualified, Title 24 compliant and meet the Washington State Ventilation and Indoor Air Quality Code.



The FQ-FD radiation damper together with the FQ fan will be a perfect combo that will win the multifamily orders for you.



### Customer Support:

Canada 800.565.3548 • USA 800.747.1762 • support@fantech.net • www.fantech.net

Fantech, reserves the right to modify, at any time and without notice, any or all of its products' features, designs, components and specifications to maintain their technological leadership position.

