

Installation and Operation Manual





DBF 4XLT

Duct Booster Fan

PARTS IN THE BOX

- Duct Booster Fan, 1 pc
- Fan Mounting Bracket and Hardware, 1 pc
- Indicator Panel w/ 50' (15.4 m) of cable, 1 pc
- Tubing & Grommet, 1 pc



				
Note	Warning / Important note	Information	Technical information	Practical tip



Read and Save these instructions for future reference.

This unit has rotating parts and safety precautions should be exercised during installation, operation and maintenance.

CAUTION: "For General Ventilation Use Only. Do Not Use To Exhaust Hazardous Or Explosive Materials And Vapors."

CAUTION: Do not install less than 5 linear feet (1.52 linear meters) from clothes dryer exhaust outlet.

CAUTION: Do not exhaust air in excess of 167°F (75°C).

CAUTION: Do not install in an exhaust ductwork of a clothes dryer whose instructions prohibit the installation of a clothes dryer booster fan.

CAUTION: Insulated dryer duct shall not be used upstream of the ventilator.

CAUTION: The ventilator must be used in conjunction with high output dryers.

CAUTION: Do not install in an exhaust ductwork where the equivalent duct length is < 25 feet (7.62 meters). The DBF4XLT is suitable to overcome an equivalent duct length up to 130 feet (40 meters) using a 4 inch diameter galvanized steel duct, and to maintain an air velocity of 1200 fpm (6.10 m/s).

CAUTION: A secondary lint trap must be installed between the clothes dryer and the dryer booster fan if the booster fan is located less than 15 linear feet (4.6 linear meters) from the exhaust of the clothes dryer.

Warnings

DO NOT CONNECT POWER SUPPLY UNTIL FAN IS COMPLETELY INSTALLED. The DBF4XLT is provided with a 120VAC power cord.

1. WARNING! TO REDUCE THE RISK OF FIRE, ELECTRIC SHOCK, OR INJURY TO PERSONS - OBSERVE THE FOLLOWING:
 - a. Use this unit only in the manner intended by the manufacturer. If you have questions, contact the factory.
 - b. Before servicing or cleaning, **unplug power cord or switch power off at service panel and lock service panel to prevent fan from being switched on accidentally.** When the service disconnecting means cannot be locked, securely fasten a prominent warning device, such as a tag, to the service panel.
 - c. Installation work and electrical wiring must be done by qualified personnel in accordance with all applicable codes and standards, including fire-rated construction.
 - d. The combustion airflow needed for safe operation of fuel burning equipment may be affected by this unit's operation. Follow the heating equipment manufacturer's guidelines and safety standards such as those published by the National Fire Protection Association (NFPA), the American Society of Heating, Refrigeration, and Air Conditioning Engineers (ASHRAE), and the local code authorities.
 - e. When cutting or drilling into wall or ceiling, do not damage electrical wires or other hidden utilities.
 - f. Ducted fans must always be vented to the outdoors.
2. If a visual error indicator is activated, do not operate the clothes dryer. See section in this instruction manual titled "Error Indications".

Installation Guidelines



TO PREVENT THE POSSIBILITY OF DRYER FAN CAVITATION AND/OR EXHAUSTING EXCESS HEAT REQUIRED FOR THE DRYING CYCLE AND COMPROMISING DRYING TIMES, BOOSTER FAN AIRFLOW MUST NOT EXCEED THE DRYER FAN CAPACITY.

Calculating Duct Run

To calculate the length of your planned duct run, measure from the dryer to external venting point in roof or wall. For each bend or elbow add 5-7 feet to your total duct run calculations. The DBF4XLT can be installed on runs up to 130 feet.

Fan and Switch Mounting

The DBF4XLT is to be mounted a minimum of 5 linear (not equivalent) feet from the dryer outlet. Exception: A secondary lint trap can be used where required and in applications where excessive lint generation is likely or to increase the time interval between routine maintenance of the Duct Booster Fan. (See illustration on next page). An Mounting Bracket (included) attached to a rafter or joist should be used to stabilize the fan. Although not recommended, a vertical rigid duct may support the fan if the duct is securely stabilized. (Consult local codes prior to supporting the fan in the duct alone.) Refer to maintenance instructions for inspection recommendations. All duct connections should be properly sealed to prevent leakage and loss of fan performance. Flex duct (if allowed by building codes) should be stretched as smooth as possible.

Indicator Panel

The DBF4XLT is equipped with a remote mounted low voltage operation indicator panel. This panel contains an LED that will indicate proper operation of the booster fan. In the event of a problem with the system, it will indicate the nature of the problem.

Pressure Sensor Switch Operation

The DBF4XLT contains a positive pressure sensing switch, which recognizes airflow velocity and activates the booster fan from an independent electrical circuit. This eliminates connections through the dryer circuit which may void the manufacturers' warranty as well as manual systems, which require the attention of the operator or costly current/temperature sensing systems.

Power to the booster fan is connected in series through a normally open terminal on the switch. A pressure tap is connected to a nipple on the side of the switch. When the dryer begins operation, positive pressure in the duct causes the switch diaphragm to expand closing the circuit to the booster fan. An integral delay-on-break timer in the switch will cycle the fan on for intervals of 10 minutes. Cycle will reinitiate after a few seconds as long as the dryer is operating. This will continue until the dryer has stopped and the timer delay period has lapsed. Drying cycles, the booster fan, the delay timer, and the pressure switch are not adversely affected by the starting/stopping intervals.

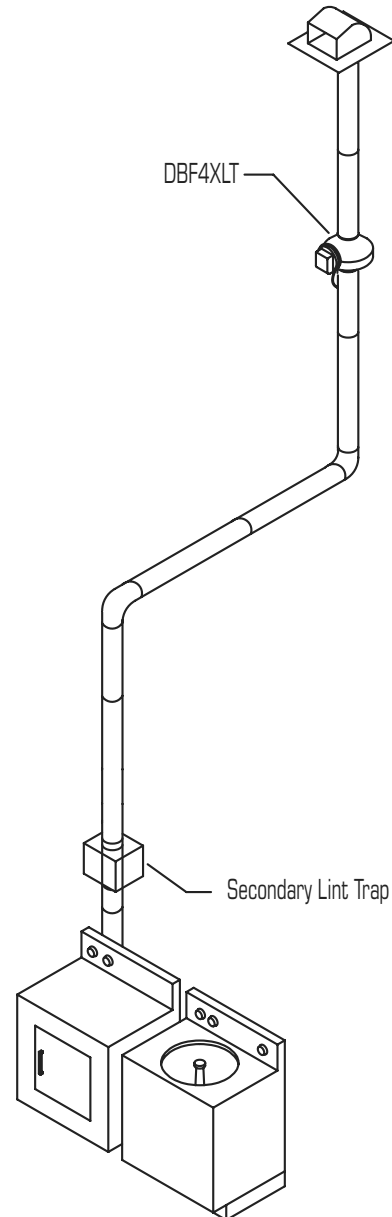

DBF4XLT Fan/Switch Installation Instructions

Indicator Panel Installation

Step 1. Selecting Panel Location

The DBF4XLT indicator panel mounts near the dryer in a location that will be visible to the operator of the dryer. The indicator panel is supplied with 50 feet of cable. Ensure that the indicator panel and booster fan are located to allow their connection with this cable.

Step 2. Wiring and Mounting Panel

The indicator panel is a low voltage device that is not required to be installed in an electrical junction box. If provided with clearance for the cable and terminal block it can be mounted to a wall using appropriate fasteners.

If installer chooses to mount indicator panel in a single gang junction box (by others), **it should not be installed in a box that contains line voltage wiring or devices.**

On the end of the 50 foot cable with stripped wires connect red wire to the positive (+) position of the terminal block on the indicator panel. Connect black wire to the negative (-) position of the terminal block on the indicator panel as shown in Figure 1.1.

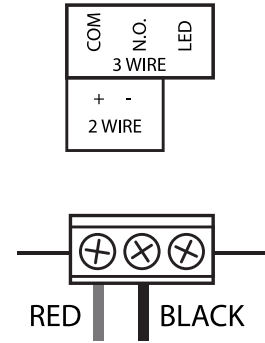

Figure 1.1

Fan Installation

Step 1. Selecting Fan Location

The indicator panel is supplied with 50 feet of cable. Ensure that the indicator panel and boost fan are located to allow their connection with this cable.

Fan must be mounted a minimum of 5 linear feet from the dryer outlet. In order to perform recommended maintenance, fan location should allow sufficient access for service. Refer to dimensional drawings shown on the next page.

NOTE: Steps 2 & 3 may be reversed.

Step 2. Mount Bracket

Using the 3/4" wood screws provided, attach the mounting bracket to a support beam at the selected location. (See Figure 1.2) Fan mounting can be done at any angle, however, vertical mounting is recommended to reduce condensation buildup in the fan. If a horizontal installation is necessary and condensation buildup may pose a problem, a 1/4" hole drilled in the bottom of the housing (along with an NPT insert (by others) and drain tubing) may be installed to allow condensation to drain.

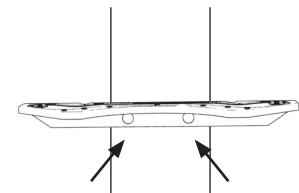

Figure 1.2

Mount Bracket
(use 3/4" long wood screws)

Step 3. Mount Fan

For proper operation, the control box (located on the fan) needs to be positioned properly. See illustrations on Figure 1.3 show the correct control box position for fans that are mounted horizontally, vertically and at an angle. The control box should also be positioned to provide access to the indicator panel wiring and the tubing connections. Attach fan to the mounting bracket with the self tapping 1/2" screws provided. Care should be taken not to strip the housing. Although screw pilot holes are not required, 3/32" (or smaller) pilot holes are recommended. See Figure 1.4

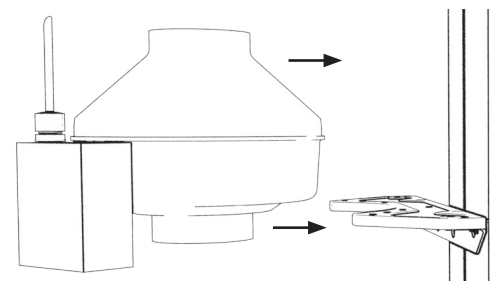

Figure 1.3

Mount Fan
(use 1/2" long self tapping screws)

Step 4. Connect Indicator Panel Cable

Connect the end of the 50 foot cable that has a two position connector to the receptacle located on the dryer booster fan control box.

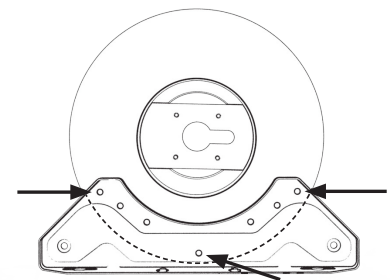

Figure 1.4

Mounting Bracket and
Screw Locations

**(using the wrong length screws
will damage the fan impeller)**

Pressure Switch Positioning

Figure 1.5

Correct Switch Positioning - Diaphragm Positioned Vertically

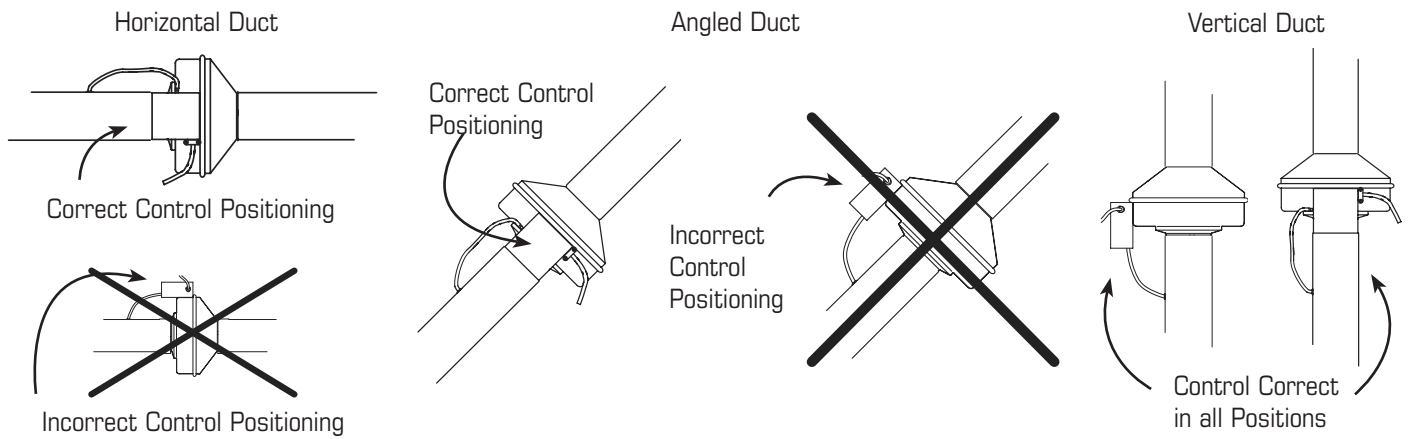

Dimensions

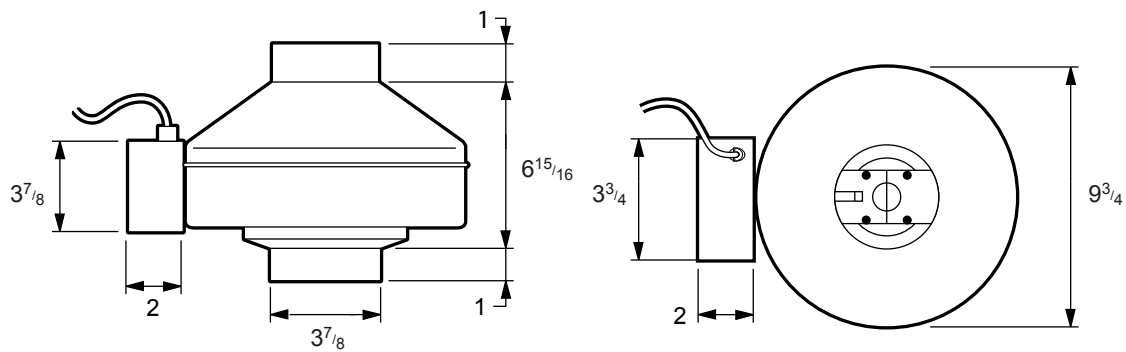

All dimensions in inches.

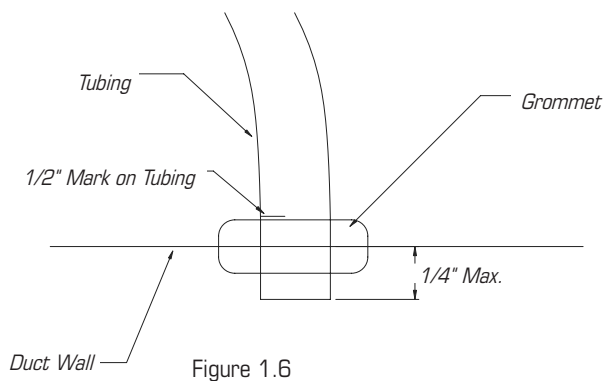

Figure 1.6

Step 5. Installing Grommet and Tubing

Do not connect tubing in such a manner as to allow condensation from the duct to collect in the tubing.

First, drill a 5/16 inch to 3/8 inch diameter hole in the duct wall. Carefully insert the grommet into the hole. (Drilling a metal duct may produce burrs. Be careful not to be cut or pricked by the burrs or the duct.) Next, force one end of the tubing over the nipple on the control. Make a mark a distance of 1/2 inch from the other end of the tubing. Slide this end of the tubing through the center of the grommet up to the mark as illustrated. (See Figure 1.6)

Recommended Maintenance

1. Since fan bearings are sealed and provided with an internal lubricating material, no additional lubrication is necessary.
2. Fan impeller may accumulate lint. Periodic inspection, based upon dryer usage, should be performed to ensure that the fan impeller is not obstructed or loaded with lint. Under normal conditions, fan should be inspected a minimum of every Six (6) Months. **Note:** Excessive booster fan noise or vibration may be an indication of lint buildup on the impeller. To inspect and clean the impeller:
 - a. Disconnect the incoming power supply at the source.
 - b. Remove the duct from the fan inlet and remove any lint buildup on the impeller.
 - c. Reconnect the duct to the fan. Turn power supply on.

Troubleshooting

This is a simple procedure to verify proper operation of the booster fan. It should be run at setup to verify that the system is operating correctly. In normal operation the system will indicate the status of the booster fan; however, this process can also be repeated as a system diagnostic.

- a. Generally, if the indicator LED is not illuminated it is OK to run the test. Should you notice any behavior other than that described below, shut the dryer off and wait at least 5 minutes to allow the system to reset and then run the test again.
- b. Start the dryer and run it for a period of 1 minute.
- c. The indicator LED should illuminate about 10 seconds after the dryer starts.
- d. The booster fan should stop 5 to 10 minutes after the dryer stops.
- e. Indicator LED should remain illuminated for 5 to 10 minutes after the dryer stops.
- f. If indicator LED does not illuminate or flashes, see error indication section. Otherwise, the booster fan is functioning correctly.

Error Indications

If the LED flashes or does not illuminate, check the list below for error indication and likely sources of the problem. Should your DBF4XLT show an error other than what is listed, or if these help topics do not solve the problem, please contact Fantech's Technical Assistance Department for further assistance.

Contacts

United States: 800.747.1762
 Canada: 800.565.3548

1. The LED illuminated in a steady state indicates that the Dryer Booster Fan is operating properly.
2. If LED does not illuminate when clothes dryer is on, check the booster fan operation.
 - If it is not working, verify that the booster fan is properly connected to a 120V AC power source.
 - Verify that there are no obstructions in the duct between the clothes dryer and the Dryer Booster Fan.
 - Verify that the clear plastic tubing is connected between the nipple on the Dryer Booster Fan and the clothes dryer duct (see Step 5 of Fan Installation).
 - If it is working
 - Verify that the low voltage wire is properly plugged into the booster fan.
 - Check the polarity of the low voltage connection to the indicator panel (red to positive, black to negative). If the polarity is reversed the LED will not illuminate.
3. LED flashes evenly
 - This indicates a locked rotor condition. The fan is receiving power, but the motor is not turning. Check the booster fan for obstruction or motor failure.
4. LED flashes twice followed by a brief pause
 - This indicates that the booster fan is operating at less than its standard speed. Check the boost fan for buildup of debris or motor damage.
5. LED flashes three times followed by a brief pause
 - This is indicating that the system airflow has dropped. Check duct system for obstructions. LED flashes that appear after the clothes dryer has turned off are a result of decreased airflow through the duct system caused by the clothes dryer turning off and does not require any action. If LED flashes are present when the clothes dryer is running, corrective action should be taken.

Email: support@fantech.net

Warranty

Five (5) Year Warranty

This warranty supersedes all prior warranties

DURING ENTIRE WARRANTY PERIOD:

Fantech will repair or replace any part which has a factory defect in workmanship or material. Product may need to be returned to the Fantech factory, together with a copy of the bill of sale and identified with RMA number.

FOR FACTORY RETURN YOU MUST:

- Have a Return Materials Authorization (RMA) number. This may be obtained by calling Fantech either in the USA at 1.800.747.1762 or in CANADA at 1.800.565.3548. Please have bill of sale available.
- The RMA number must be clearly written on the outside of the carton, or the carton will be refused.
- All parts and/or product will be repaired/replaced and shipped back to buyer; no credit will be issued.

OR

The Distributor may place an order for the warranty part and/or product and is invoiced. The Distributor will receive a credit equal to the invoice only after product is returned prepaid and verified to be defective.

FANTECH WARRANTY TERMS DO NOT PROVIDE FOR REPLACEMENT WITHOUT CHARGE PRIOR TO INSPECTION FOR A DEFECT. REPLACEMENTS ISSUED IN ADVANCE OF DEFECT INSPECTION ARE INVOICED, AND CREDIT IS PENDING INSPECTION OF RETURNED MATERIAL. DEFECTIVE MATERIAL RETURNED BY END USERS SHOULD NOT BE REPLACED BY THE DISTRIBUTOR WITHOUT CHARGE TO THE

Limitation of Warranty and Liability

This warranty does not apply to any Fantech product or part which has failed as a result of faulty installation or abuse, incorrect electrical connections or alterations made by others, or use under abnormal operating conditions or misapplication of the product or parts. We will not approve for payment any repair not made by us or our authorized agent without prior written consent. The foregoing shall constitute our sole and exclusive warranty and our sole exclusive liability, and is in lieu of any other warranties, whether written, oral, implied or statutory. There are no warranties which extend beyond the description on the page hereof. In no event, whether as a result of breach of contract, or

Warning

Fantech products are designed and manufactured to provide reliable performance, but they are not guaranteed to be 100% free from defects. Even reliable products will experience occasional failures and this possibility should be recognized by the user. If these products are

used in a life support ventilation system where failure could result in loss or injury, the user should provide adequate backup ventilation, supplementary natural ventilation, failure alarm system, or acknowledge willingness to accept the risk of such loss or injury.

END USER, AS CREDIT TO DISTRIBUTOR'S ACCOUNT WILL BE PENDING INSPECTION AND VERIFICATION OF ACTUAL DEFECT BY FANTECH.

THE FOLLOWING WARRANTIES DO NOT APPLY:

- Damages from shipping, either concealed or visible. Claim must be filed with freight company.
- Damages resulting from improper wiring or installation.
- Damages or failure caused by acts of God, or resulting from improper consumer procedures, such as:
 1. Improper maintenance
 2. Misuse, abuse, abnormal use, or accident, and
 3. Incorrect electrical voltage or current.
- Removal or any alteration made on the Fantech label control number or date of manufacture.
- Any other warranty, expressed, implied or written, and to any consequential or incidental damages, loss or property, revenues, or profit, or costs of removal, installation or reinstallation, for any breach of warranty.

WARRANTY VALIDATION

- The user must keep a copy of the bill of sale to verify purchase date.
- These warranties give you specific legal rights, and are subject to an applicable consumer protection legislation. You may have additional rights which vary from state to state.

warranty or alleged negligence, defect incorrect advice or other causes, shall Fantech be liable for special or consequential damages, including, but not limited to, loss of profits or revenue, loss of use of equipment or any other associated equipment, cost of capital, cost of substitute equipment, facilities or services, downtime costs, or claims of customers of purchase for such damages. Fantech neither assumes or authorizes any person to assume for it any other liability in connection with the sale of product(s) or part(s). Some jurisdictions do not allow the exclusion or limitation of incidental or consequential damages so the above limitations and exclusions may not apply to you.

used in a life support ventilation system where failure could result in loss or injury, the user should provide adequate backup ventilation, supplementary natural ventilation, failure alarm system, or acknowledge willingness to accept the risk of such loss or injury.

Fantech reserves the right to make technical changes.
For updated documentation please refer to www.fantech.net

Fantech®