

# DB10 PRESSURE SENSING SWITCH KIT INSTALLATION INSTRUCTIONS



1712 Nortngate Blvd. - Sarasota, FL. 34234  
Phone: (800) 747-1762 Fax: (800) 487-9915  
Phone: (941) 351-2947 Fax: (941) 3593828  
Web Site [www.fantech-us.com](http://www.fantech-us.com)

## Positive Pressure Sensor Fan Proving Switch and Fan

### DB10 Kit Includes:

- 1 DB10 Pressure Switch with Integral Delay
- 1 3' Section of NPT Tubing
- 1 Grommet for Tubing
- 4 Wire Nuts for Electrical Connection
- 1 Packet with Switch Mounting Hardware

***IMPORTANT NOTICE: READ and SAVE THESE INSTRUCTIONS for FUTURE REFERENCE.***

## Pressure Sensor Switch Operation

*Fantech's DB10* is a positive pressure sensing switch which recognizes dryer operation and activates the booster fan from an independent electrical circuit. This eliminates connections through the dryer circuit which may void the manufacturers' warranty as well as manual systems which require the attention of the operator or costly current/temperature sensing systems.

The electrical to the booster fan is connected in series through a normally open terminal on the switch. A pressure tap is connected to a tip on the side of the switch. When the dryer begins operation, positive pressure in the duct causes the switch diaphragm to expand closing the circuit to the booster fan. An integral delay-on-make timer in the switch will cycle the fan on for intervals of 10 minutes. This will continue until the dryer has stopped and the timer delay period has lapsed. Drying cycles, the booster fan, the delay timer and the pressure switch are not adversely affected by the starting/stopping intervals.

## Installation Guidelines

The DB10 switch can be mounted at any point in the duct *between* the dryer and booster fan. However, in installations when the switch is used to control an RVF fan, it may be necessary to locate the DB10 in front of an elbow. (See additional installation instructions on Pages 2 and 3.) Be certain to allow adequate space for the switch. Refer to the dimensional data shown below. For optimum switch sensitivity, the diaphragm *must* be mounted vertically. Refer to the illustrations in the middle of Page 2 of these instructions for correct and incorrect switch diaphragm positioning. The switch should be mounted within 30 inches from the point where the pressure tap will be inserted into the dryer exhaust duct.

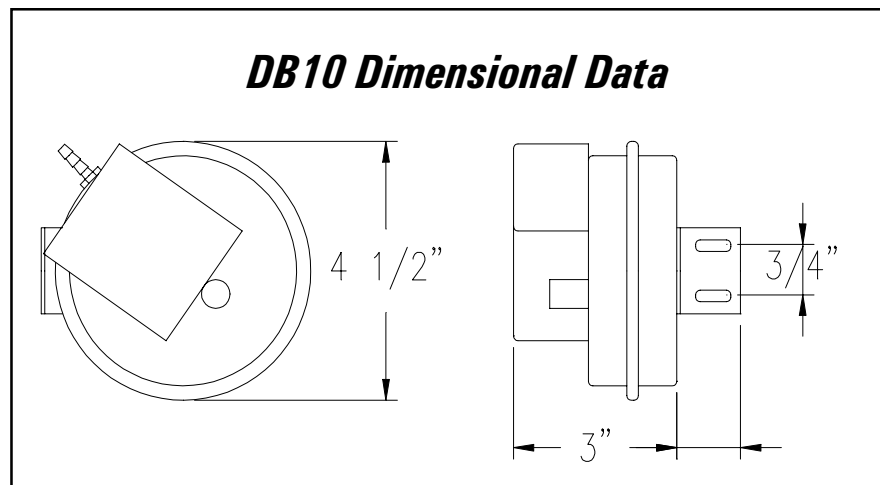

## Installation Instructions

### Step 1. Selecting Switch Location

Switch must be located *between* the dryer and the booster fan in order to work properly. Switch can be installed at any point along the duct run. However, if the switch is used in conjunction with an RVF fan, the best location may be upstream of an elbow. (Refer to Page 3 of these instructions for additional installation details.)

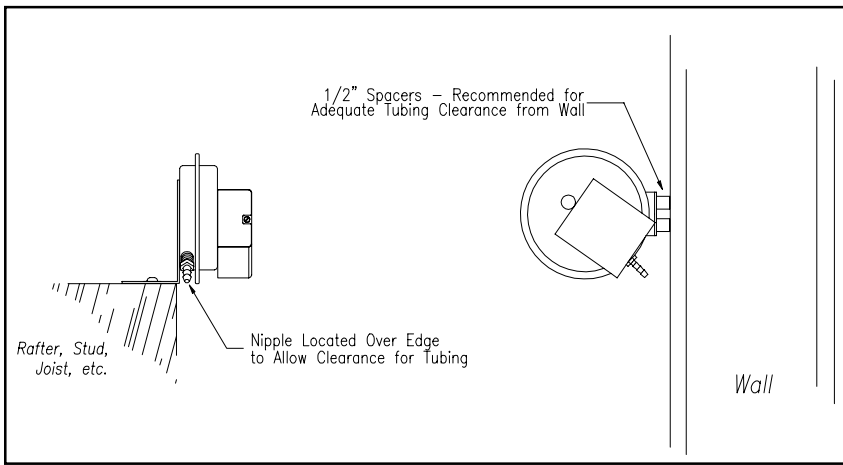

## Step 2. Mount Switch

*Note: Switch diaphragm must be mounted vertically for optimum sensitivity. Refer to illustrations below.*

When mounting the switch to a stud, joist, rafter, etc., in order to prevent the tubing from being crimped, locate the nipple so that it clears the edge of the beam. (Refer to illustration at left.) Using the wood screws provided, secure the switch to the beam. When mounting the switch to a wall, mount the 1/2" spacers provided between the switch mounting bracket and the wall to prevent the tube from being crimped. When mounting the switch to drywall, concrete, etc., it is recommended that the anchors provided be used to securely hold the screws.

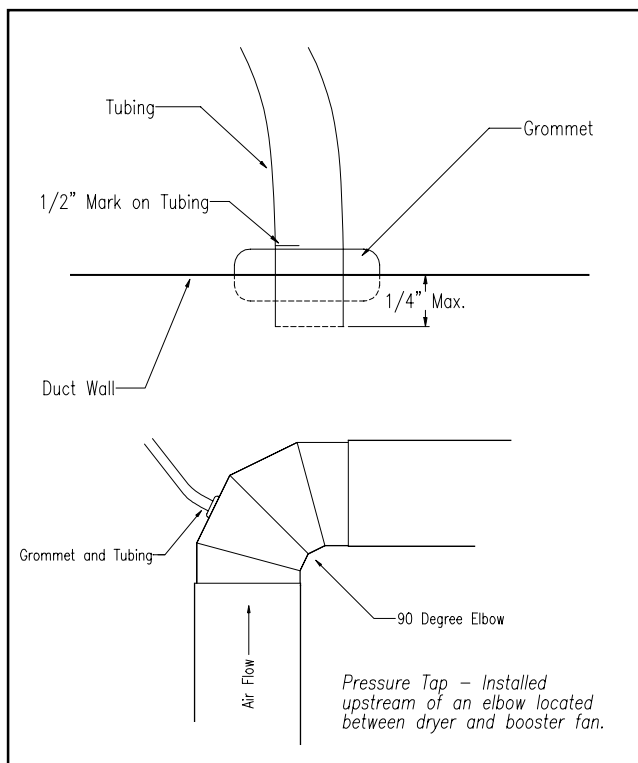
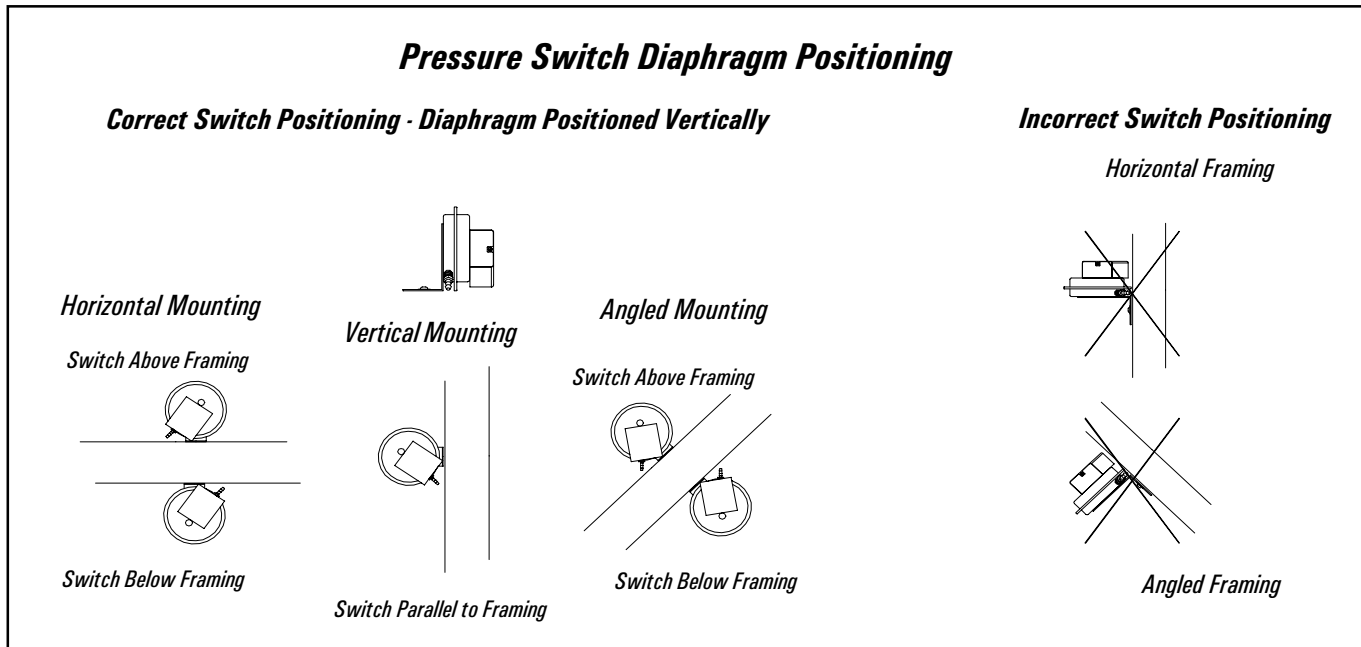

## Step 3. Installing Grommet and Tubing

*Note: Grommet should be mounted no more than 30 inches from the pressure switch in order to allow the tubing to reach from the switch to the duct.*

First, drill a 1/4 inch to 5/16 inch diameter hole in the duct wall. Carefully insert the grommet into the hole. (Drilling a metal duct may produce burrs. Be careful not to be cut or pricked by the burrs or the duct.) Next, force one end of the tubing over the nipple on the switch. It may be necessary to use a lubricant in order to slide the tubing over the entire nipple. Make a mark a distance of 1/2 inch from the other end of the tubing. Slide this end of the tubing through the center of the grommet up to the mark as illustrated. Do not use a lubricant on this end of the tubing.

For some installations, it may be necessary to insert the grommet and tubing, or duct "pressure tap", in the upstream side (side the air enters) of an elbow. Applications which may require that the tap be located upstream of an elbow include installations with an RVF fan mounted at the end of a long straight duct run (15' or more) or regions in higher elevations.

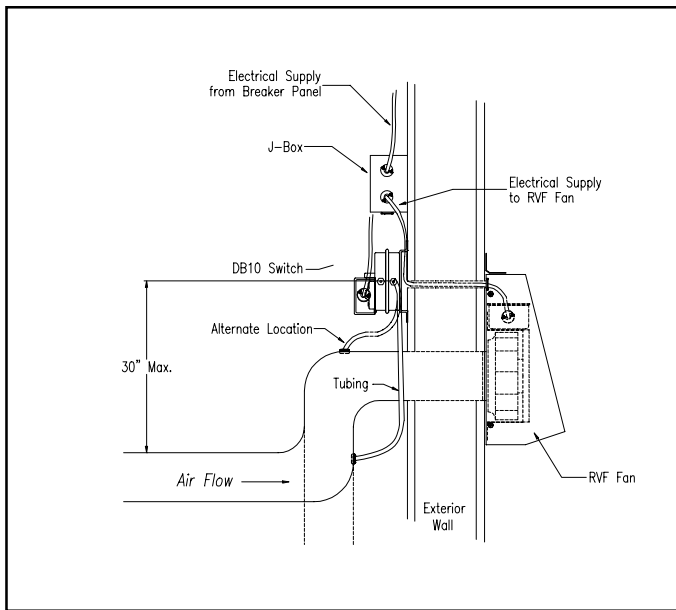

### Additional Installation Notes: DB10 used with an RVF Series Fan

The RVF Series fans create very little resistance against the dryer fan air flow when the RVF fan is not operating. A minimum amount of pressure (approximately 0.05" - 0.07") is required in order to trigger the switch. For installations where there is a long horizontal duct run prior to terminating at the fan, it may be necessary to insert one or two elbows. The elbow(s) increase the static pressure on the upstream side of the elbow. As illustrated, the duct pressure tap should then be installed in the upstream side of the first elbow. The dotted lines show an alternate location for the pressure tap for systems with one elbow added. As an alternative to inserting an elbow near the fan, the switch and pressure tap may be located upstream of an existing elbow (as shown on Page 2) or may be installed closer to the dryer.

### Additional Installation Notes: DB10 used with an Inline Fan

Unlike the RVF Series, the FR and FX Series fans create enough resistance to the dryer fan flow to trigger the pressure switch. When using the switch with an inline fan, the switch and pressure tap may be installed near the fan or at any point along the duct between the dryer and the fan. One advantage to locating the switch and pressure tap near the fan are proximity to one another for servicing, maintenance, troubleshooting, etc.

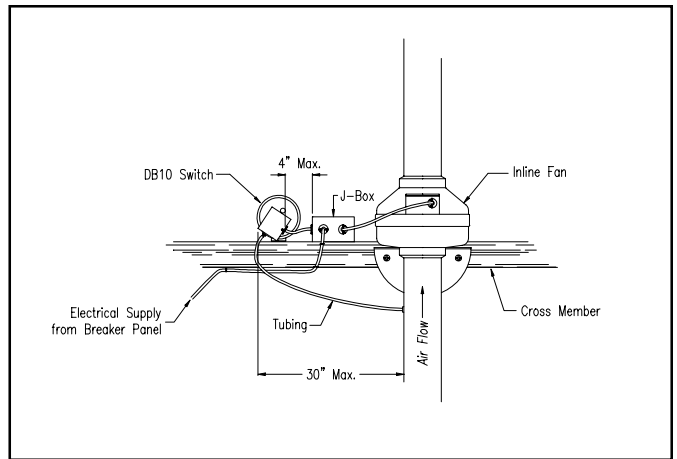

### Electrical Connection

**DO NOT CONNECT POWER SUPPLY UNTIL SWITCH IS COMPLETELY INSTALLED. MAKE SURE ELECTRICAL SERVICE TO THE SWITCH IS LOCKED IN "OFF" POSITION.**

**WARNING: TO REDUCE THE RISK OF FIRE, ELECTRIC SHOCK, OR INJURY TO PERSONS - OBSERVE THE FOLLOWING:**

1. Use this unit only in the manner intended by the manufacturer. If you have questions, contact the factory.
2. Before servicing or cleaning, switch power off at service panel and lock service panel to prevent circuit from being switched on accidentally. When the service disconnecting means cannot be locked, securely fasten a prominent warning device, such as a tag, to the service panel.
3. Installation work and electrical wiring must be done by qualified person(s) in accordance with all applicable codes and standards, including fire-rated construction.
4. When cutting or drilling into wall or ceiling, do not damage electrical wires or other hidden utilities.

*Note: DB10 is suitable for use only with the following fans:  
FR100, 110, 125, 140, 150, 160, 200, 225; K/FX4, 4XL, 5, 5XL, 6, 6XL,  
8, 8XL, 10; RVF4, 4XL, 6, 6XL, 8XL; RE(C)/KRD(C) 6, 8XL.*

### Wiring Procedure

#### Step 1.

A 4"x4" junction box (J-Box) is recommended for adequate space for all wiring connections. The box should be mounted a maximum of 4 inches from the switch. (Refer to illustrations above.)

#### Step 2.

Using the wire nuts provided, connect the incoming electrical supply, the switch leads and the power supply to fan as shown in the schematic on the right.

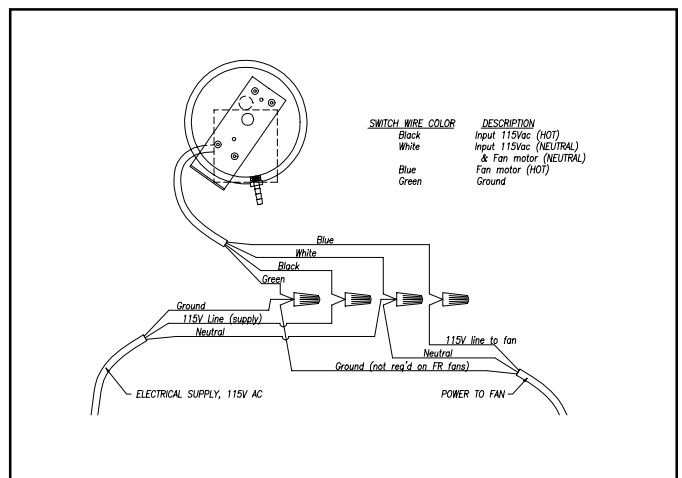

# WARRANTY and MAINTENANCE

## Recommended Maintenance

1. Since fan bearings are sealed and provided with an internal lubricating material, no additional lubrication is necessary.
2. Fan impeller may accumulate lint. Periodic inspection, based upon dryer usage, should be performed to ensure that the fan impeller is not obstructed or loaded with lint. Under normal conditions, fan should be inspected a minimum of every Six (6) Months. *Note: Excessive booster fan noise or vibration may be an indication of lint buildup on the impeller.* To inspect and clean the impeller:
  - a. Disconnect the incoming power supply at the source.
  - b. Remove the duct from the fan inlet and remove any lint buildup on the impeller.
  - c. Reconnect the duct to the fan. Turn power supply on.

## Troubleshooting

**Important Notice:** Prior to performing Steps 1 - 4, be certain that the electrical supply to the fan/switch is turned off.

If fan fails to start when the dryer cycle begins, please follow the procedure listed below:

1. Check the incoming supply for proper voltage.
2. Consult schematic shown on Page 2 to ensure proper connection. For additional reference, fan wiring diagrams are shown below.
3. Use a meter to test for continuity across the fan motor leads. In order to do this, the capacitor must be disconnected (do not test the capacitor - capacitors do not meter continuity). If motor leads show continuity, rewire the fan.
4. Turn on the electrical supply and restart the dryer cycle. Check to be certain that fan starts.

If fan still fails to start after performing Steps 1 - 4, continue following the procedure as listed below:

5. Verify that the pressure switch diaphragm is vertical as illustrated on Page 2 of these instructions. If the diaphragm is not vertical, reposition the pressure switch and check for fan operation against another dryer cycle.
6. Verify that the tubing is not crimped and that the tubing connections are not obstructed.
7. If switch diaphragm is vertical and fan still fails to start, with the electrical supply on:
  - a. Remove the tubing from the grommet in the duct and blow gently into the tubing;
  - b. If fan starts, consult Fantech for additional technical support.
8. If fan fails to start after blowing into the tubing:
  - a. Disconnect incoming power supply at the source.
  - b. Connect the incoming power supply directly to the fan motor as shown in the appropriate diagram below.
  - c. Turn on power to fan.
9. If fan fails to start, please consult Fantech for additional technical support.

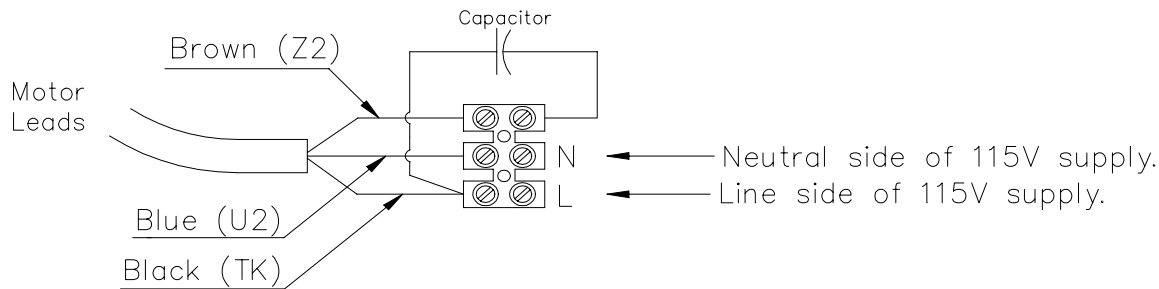

**Schematic for all FR, FX, RVF and RE/REC Models**

**Note:** Ground FX, RVF and RE/REC Models beneath a screw in the terminal box.

No ground is necessary for FR Models.

## FIVE (5) YEAR WARRANTY

### THIS WARRANTY SUPERSEDES ALL PRIOR WARRANTIES

#### FOR FACTORY RETURN YOU MUST:

- 1) Have a Return Materials Authorization (RMA) number. This number may be obtained by calling FANTECH, INC. at 1-800-747-1762. Please have Bill of Sale available.
- 2) The RMA number must be clearly displayed on the outside of the carton, or delivery will be refused.
- 3) All product being returned must be shipped prepaid and be accompanied with a copy of the Bill of Sale.
- 4) Product will be replaced/repared and shipped back to buyer. No credits will be issued.

#### DURING THE FIRST THIRTY (30) DAYS:

FANTECH, INC. will replace any product which has a factory defect in workmanship or material. Product may be returned to either the point of purchase or the FANTECH factory, together with Bill of Sale, for an immediate replacement.

#### DURING THE FIRST THREE (3) YEARS (excluding the above 30 day period):

FANTECH, Inc. will replace any product which has a factory defect in workmanship or material. Product must be returned to the FANTECH factory, together with Bill of Sale, and identified with an RMA number.

#### DURING YEARS FOUR (4) and FIVE (5):

FANTECH, INC. will repair or replace any product which has a factory defect in workmanship or material. Product must be returned to the FANTECH factory, together with a Bill of Sale, and identified with an RMA number.

#### THE FOLLOWING WARRANTIES DO NOT APPLY:

- Damages from shipping, either concealed or visible. Claim must be filed with the carrier.
- Damages resulting from improper wiring or installation.
- Damages caused by acts of nature, or resulting from improper consumer procedures such as:
  - Improper Maintenance,
  - Misuse, abuse, abnormal use, or accident, or
  - Incorrect electrical voltage or current.
- Removal or alteration made on the FANTECH label control number or date of manufacture.
- Any other warranty, expressed, written or implied, and to any consequential or incidental damages, loss of property, revenues, or profit, or costs of removal, installation or reinstallation, for any breach of warranty.

#### WARRANTY VALIDATION:

The end user must keep a copy of the Bill of Sale to verify purchase date.