

Options

(add suffix) – PNL
2' x 2' Panel For T-Bar

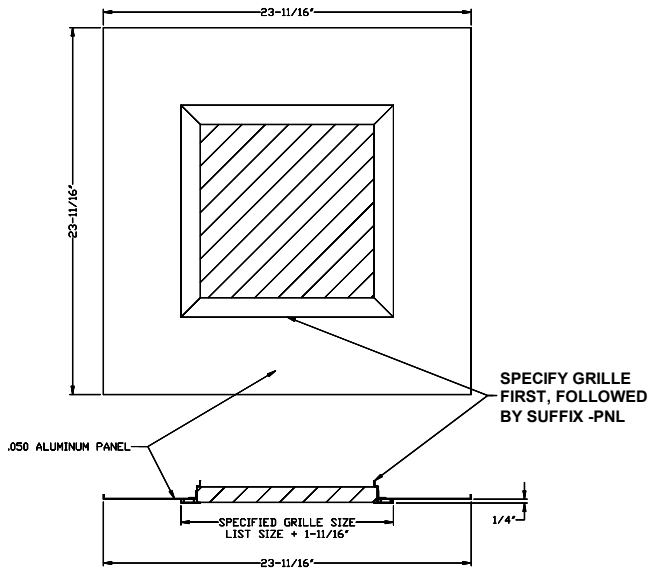

DSSR \emptyset – W x H
Square To Round Transition

\emptyset - Specify round dimension here

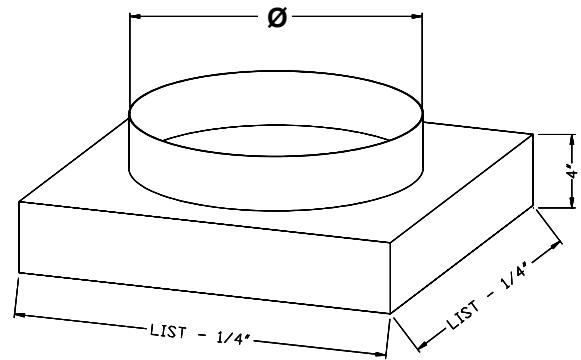

26 gauge galvanized

Screen to back side of grille

(add suffix) – IS
Aluminum Insect Screen

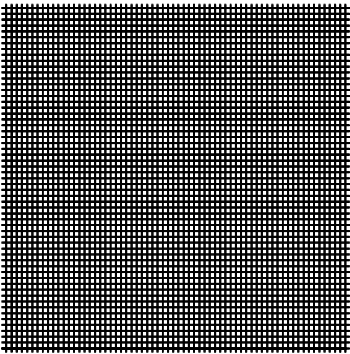

.011" Aluminum 1/16" x 1/18" Screen

(add suffix) – BS
Galvanized Bird Screen

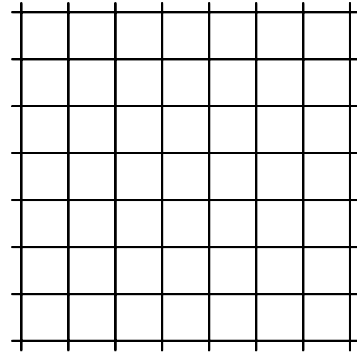

.041" Galvanized 1/2" x 1/2" Screen

DESCRIPTION	- PNL	- IS	-BS	DSSR \emptyset
FACE BLADES	n/a	n/a	n/a	n/a
REAR BLADES	n/a	n/a	n/a	n/a
DAMPER	n/a	n/a	n/a	n/a
MATERIAL	.050 Aluminum	Aluminum	Galvanized	26g Galv.
FINISH	White	Mill	Mill	Mill

JOB NAME:	_____
LOCATION:	_____
ARCHITECT:	_____
ENGINEER:	_____
CONTRACTOR:	_____