

WALL MOUNT 2500 VERSION 3

TECHNICIAN'S MANUAL

NOTICE: To activate the split system warranty, the installing certified HVAC/R service tech must complete the split system warranty checklist and send back to CellarCool.

CELLARCOOL

Conforms to ANSI/UL Std 427

Certified to CAN/CSA Std C22.2 No. 120

We manufacture, test and certify 100% of our wine cooling units in the USA. By sourcing the best components and closely controlling our manufacturing processes, we can assure the highest-quality, lowest defect manufacturing rates in the industry.

Copyright © 2017. CellarCool. All rights reserved.

CellarCool copyrights this manual, the product design, and the design concepts, with all rights reserved. Your rights with regard to the hardware and manual are subject to the restrictions and limitations imposed by the copyright laws of the USA. Under copyright laws, this manual may not be copied, reproduced, translated, transmitted, or reduced to any printed or electronic medium or to any machine-readable form, for any purpose, in whole or in part, without the written consent of CellarCool.

Every effort has been made to ensure that the information in this manual is accurate. CellarCool is not responsible for printing or clerical errors.

CellarCool reserves the right to make corrections or improvements to the information provided and to the related hardware at any time, without notice.

Vinothèque and CellarCool are registered trademarks, and ECE is a trademark of CellarCool. All rights reserved.

Mention of third-party products is for informational purposes only and constitutes neither an endorsement nor a recommendation. CellarCool assumes no liability with regard to the performance or use of these products.

TABLE OF CONTENTS

Introduction	2
Quick Start Guide	3
Before You Start	4
Receiving & Inspecting the System	5
Quick Reference Guide	
Evaporator.....	6
Display Layout & Unit Specifications	7
Evaporator Installation	
Items to Route before Installing the Evaporator Unit.....	9
Preparing the Evaporator Unit.....	10
Installing the Evaporator Unit	12
Drain Line.....	14
Liquid-Measuring Thermostat System	15
Remote Display: Installation and Configuration	16
Preparing the Condensing Unit	22
Wiring Diagrams	
WM2500 Evaporator Wiring Diagram.....	23
WM2500 Condensing Unit Wiring Diagram	24
WM2500 Condensing Unit with Cold Weather Start Kit	25
Installing the Condensing Unit.....	26
Line Set Piping Diagram	27
System Operation	34
Controller Functions.....	36
CellarCool Troubleshooting Guide.....	42
Maintenance Schedule	44
Technical Assistance & Accessories	46
Installation Terms & Conditions	47

CellarCool requires that a **certified HVAC-R technician** install, pipe, evacuate, charge, start and test all split systems. A NATE Certification is recommended. Please take a moment to review state and city building codes to ensure the safe and proper installation of the system.

Read, understand and comply with the unit's installation manual, and piping diagrams.

INTRODUCTION

Customer Service

Thank you for purchasing a CellarCool cooling system. We strive to provide the highest-quality products and the best possible customer service. If you have any questions about your system, please call us at 1-800-343-9463 or visit cellarcool.com.

Using the Manual

This owner's manual is intended to assist in the proper maintenance of the cooling system. In order to ensure the longevity of your cooling unit, the equipment should be installed as outlined in the technician's manual. It is also vital to establish a proper care and maintenance schedule. Please read and review this manual carefully and keep it for future reference.

What is the CellarCool Cooling System?

The CellarCool cooling system is a specialized refrigeration system designed for one purpose only: to maintain the optimal temperature and humidity levels conducive to the proper storage and aging of fine wines. This system produces minimal in-cellar noise and has the most lenient exhaust requirements. An exterior housing is required for outdoor condensing unit installations.

How Does the Cooling System Work?

Similar to the air conditioning systems used for homes, the evaporator unit and condensing units are installed in separate locations and are connected by a refrigerant line set. The evaporator portion is commonly installed in the wine cellar, with the condensing unit located either outside or in a remote indoor location that is ventilated. An exterior housing is required for outdoor condensing unit installations.

Temperature Setting

The system is designed to maintain a cellar temperature of 55°F as long as the ambient temperature does not exceed 110°F.

WARRANTY REGISTRATION

In order to activate the warranty of your system, the verification and operational documentation must be completed by the certified refrigeration technician installing your system and submitted via mail, fax, or e-mail.

Mail to:
CellarCool
ATTN: Warranty Registration
1738 E. Alpine Avenue
Stockton, CA 95205-2505
USA

Fax to:
209-466-4606

Scan and email to:
warranty@cellarcool.com

QUICK START GUIDE*

Pump Down Cycle

CellarCool's split systems operate on a pump down cycle different from traditional air conditioners. As such, there is no wiring between the condensing unit and evaporator unit.

CellarCool units utilize a solenoid valve on the liquid line and a low-pressure switch on the suction line. When the thermostat calls for cooling, the solenoid valve opens, permitting the flow of refrigerant. The low-pressure switch then signals the compressor to cycle on.

When the cellar reaches the desired temperature and the thermostat is satisfied, the solenoid will close, stopping the liquid refrigerant flow to the TXV valve. The compressor will continue to operate until most of the refrigerant on the low side boils off and is pumped through the compressor into the condenser coil and receiver. As the suction pressure falls below the pressure control setting, the low-pressure switch will signal the compressor to cycle off. Most of the refrigerant is now stored between the condensing unit and receiver.



WARNING: Do not utilize a ground fault interrupter, as it will prevent the unit from drawing the necessary amperage to start the unit.



TXV Adjustments

- A. A TXV adjustment may be necessary based on ambient temperatures in the cellar and at the condensing unit.
- B. Adjust the TXV until the superheat measured at the suction line service valve is 20-30°F.
- C. Under normal operation, with the wine cellar at 55°F and the ambient temperature at 85°F, the low side pressure should be between 28-32 PSI and the high side should be between 140-180 PSI.

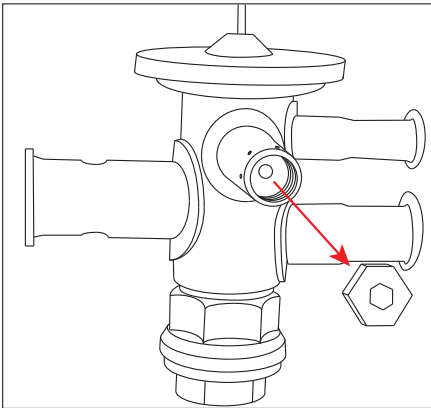
<p style="text-align: center;">TXV</p> <p>The TXV is preadjusted at the factory. If the superheat is not within 20-30° at the service valve, the TXV will need to be adjusted.</p> <p style="text-align: center;">ADJUSTING THE TXV</p> <p>Use a 5/32" hex key to remove the cap from the TXV superheat adjustment port. With the cap removed, insert the hex key into the superheat adjustment port. Increase superheat by turning the hex key clockwise. Decrease superheat by turning the hex key counterclockwise.</p>	
--	--

<p>Liquid Line King Valve</p> <p>This location is used to charge the system with liquid refrigerant and identify the high side pressure of the system.</p> <p>Calculating Subcooling</p> <p>To determine the subcooling of the system, calculate the difference between the high side pressure of the system (converted to temperature) and the temperature of the liquid line. The temperature of the liquid line will be taken at the outlet of the receiver.</p> <p>*Saturation temp — liquid line temp</p> <p style="color: red; font-weight: bold; margin-top: 10px;">4-6°F SUBCOOLING REQUIRED FOR WARRANTY APPROVAL</p>
--

*Further system operation information is available on page 34.

BEFORE YOU START

1-800-343-9463

1. **Inspect all components prior to installation.** If damage is found, please contact your distributor or CellarCool Customer Service at 1-800-343-9463.
2. The evaporator unit and condensing unit **each require a dedicated 115V, 15-amp circuit.** Use a surge protector with the unit. **Do not use a GFI** (ground fault interrupter) line.
3. The evaporator unit and condensing unit require no communication lines.
4. You are **REQUIRED** to **install a drain line** to remove condensation from the evaporator unit.
5. ***The warranty is not active until a warranty checklist has been received, reviewed, and approved.***
6. The system is intended **for use in properly designed and constructed wine cellars.** Hire a professional wine storage consultant with a valid contractor's license to build your wine cellar.
7. CellarCool requires that all split systems be installed by a certified HVAC-R technician only. NATE or equivalent is recommended.

If you encounter a problem with your CellarCool system, please refer to the Troubleshooting Guide. If you have any further questions or concerns, or need technical assistance, please contact CellarCool's Customer Service at 1-800-343-9463. Please be sure all testing has been completed prior to contacting Customer Service. Please have your results ready for your representative.

RECEIVING & INSPECTING THE SYSTEM

Upon receiving your CellarCool unit:

- Use caution when lifting and check package for damage.
- Lift only at the designated hand-hold locations on the shipping container, or fully support the unit from underneath. A shipment may include one or more boxes containing accessories.
- Before opening the container, inspect the packaging for any obvious signs of damage or mishandling.
- Write any discrepancy or visual damage on the bill of lading before signing.
- Allow the condensing unit to sit for 24 hours prior to start-up. The condensing unit can be placed in the installation location, piped and evacuated during this time.

Note: CellarCool units are manufactured in the USA and tested prior to shipment.

- Review the packing slip to verify contents
- Check the model number to ensure it is correct.
- Check that all factory options ordered are listed.

If any items listed on the packing slip do not match your order information, contact CellarCool Customer Service immediately.

Check all shipped boxes for the following contents:

Evaporator Unit Box:

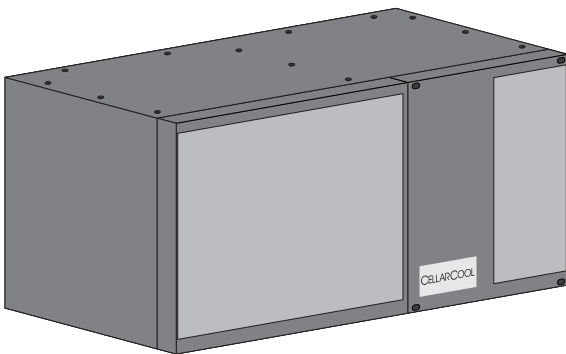

(1) WM2500 evaporator unit

Condensing Unit Box:



(1) Condensing unit

Documentation bag:

- WM2500 Version 3 owner's manual
- WM2500 Version 3 technician's manual
- R-134a split system warranty checklist
- WM2500 evaporator unit installation template

Accessory kit bag:

- Retractable bottle probe
- KDT Plus display cable (50 feet)
- KDT Plus wall mount bracket assembly
- KDT Plus flush mount bracket assembly
- KDT Plus display assembly
- Flush mount template
- Evaporator installation hardware bag
- KDT Plus hardware bag

Evaporator installation hardware bag:

- (2) 1/2" x 1/2" nylon barbed fitting
- (1) 1/2" barbed tee
- (1) Double-D strain relief
- (4) 3/4" adhesive cable tie mounts
- (2) Small cable ties
- (4) #8 x 1 3/4" hex-head screws

KDT Plus hardware bag:

- (1) 1 1/8" OD grommet
- (2) 1/2" nylon hole plug
- (4) #6 x 1" Phillips zinc Type A screw
- (4) 8-10 x 7/8" blue plastic screw anchor
- (1) Small black strain relief bushing

Condensing unit accessory kit:

- (1) Filter drier
- (1) Sight glass

Please leave the unit in its original box until you are ready for installation. This will allow you to move the product safely without damaging it. When you are ready to remove the product from the box, refer to the installation instructions.

TIP: Save your box and all packaging materials. They provide the only safe means of transporting/shipping the unit.

QUICK REFERENCE GUIDE

Front / Side View

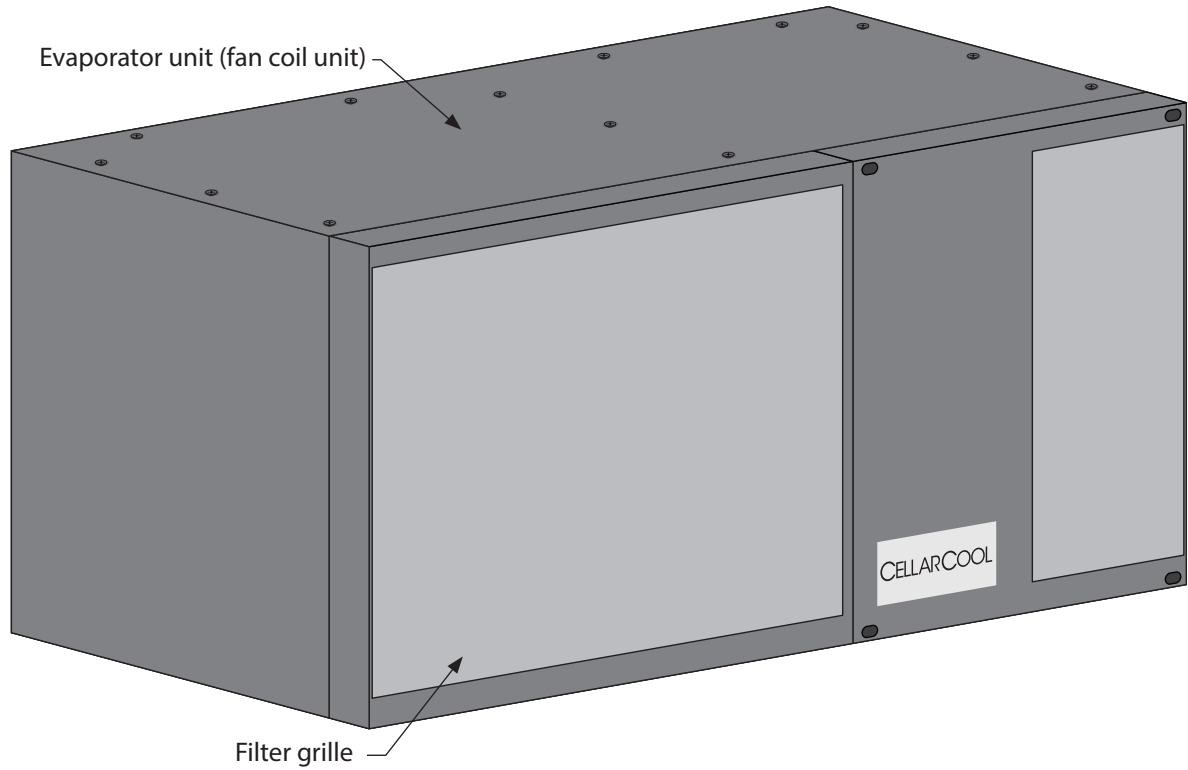

Rear / Side View

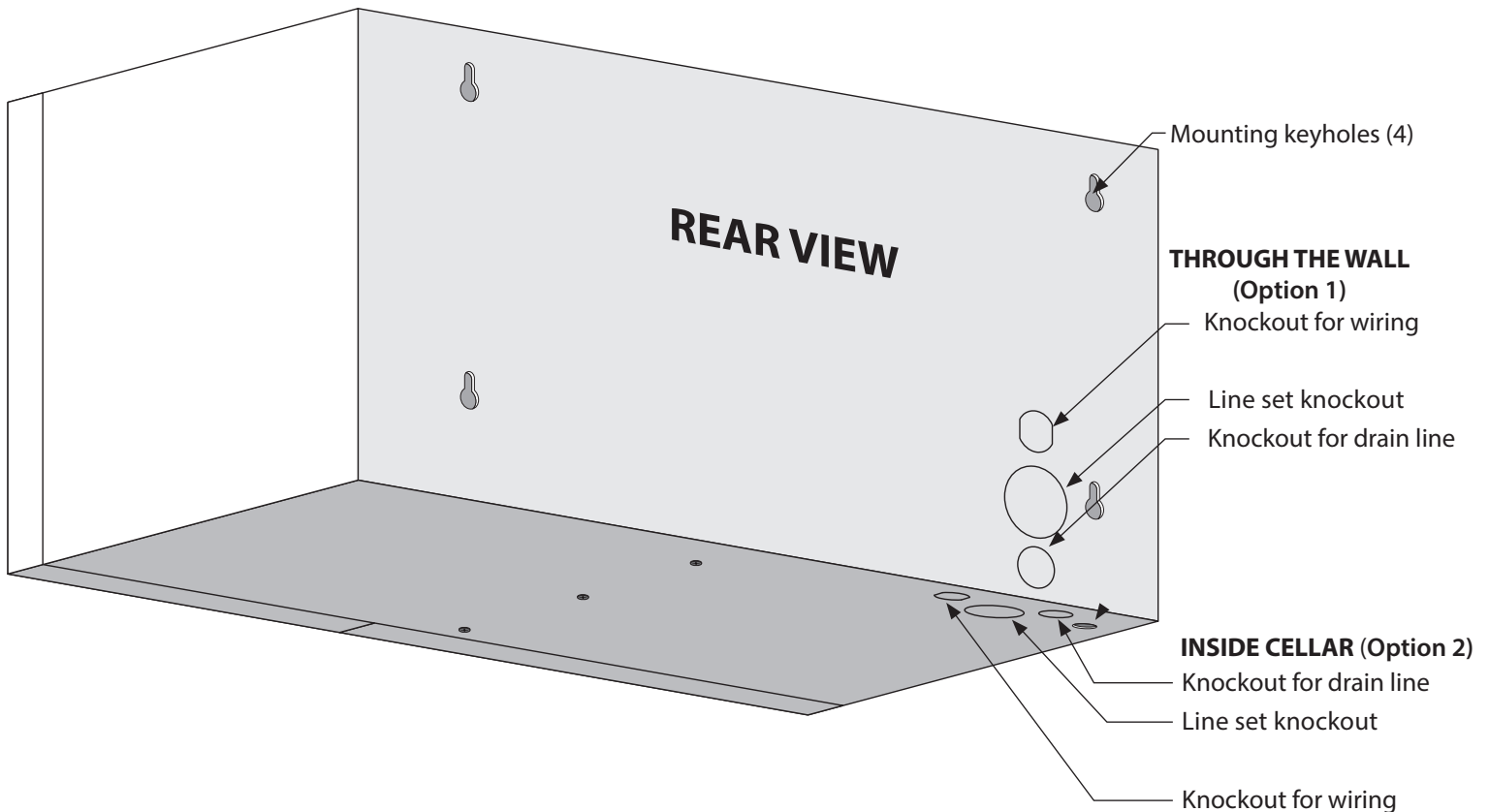

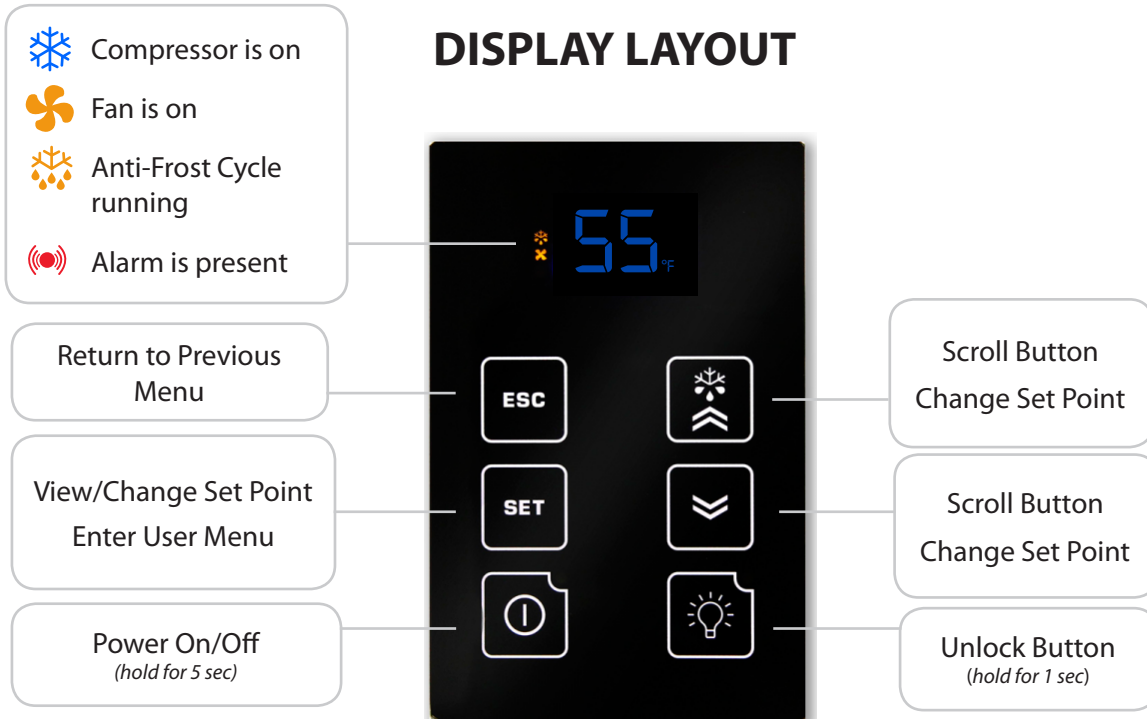

WM2500 SPECIFICATIONS

Model	WM 2500-CR Unit (Fan Coil Unit)	WM 2500-S Condenser (Air -Cooled Condensing Unit)
Cellar Size (cu. ft.)	500	
Dimensions	10.5"H x 20"W x 13"D	9.86"H x 15.85"W x 13.97"D
BTUh with 90°F air entering the condenser coil.	2101	
CFM	99	223
Refrigerant	R-134a	
Condensing Unit HP	1/6	
Voltage Rating	115V (15-amp dedicated circuit required)	
Weight (lbs)	25	38.8
Amps (LRA/RLA)	2/1	26/4.4
dBA	51	65
Line Set	Suction line 3/8" OD; liquid line 1/4" OD	
Drain Line	1/2" ID clear plastic tubing (not included)	
Installation	Evaporator unit is installed in the cellar. The condensing unit is installed up to 100 line feet away and in accordance with the installation specifications found in the technician's manual.	
Thermostat	Digital display with liquid-temperature-measuring bottle probe	
Temp. Delta	55°F temperature differential (maintains proper cellar temperature when exhaust environment does not exceed 110°F)	
Warranty	Two-year limited warranty (parts and labor)	

CELLARCOOL

SPLIT SYSTEM CHECKLIST

In order to activate the warranty for this product, the information here must be complete and accurate. Any incorrect or omitted information will result in a return trip by the installing technician at their cost.

DATA RECORDINGS

Note: All readings need to be taken while the compressor is running.

Line Set Information

- A. Line set length:
- B. Suction line OD:
- C. Liquid Line OD:

Bottle Probe

- A. Install probe in bottle of warm water to keep system operating.

Charging the System

- A. Fill system until bubbles dissipate from sight glass.
NOTE: Be careful not to overcharge the system.

Temperature Differential at the Evaporator

- A. Measure return air and supply air temperatures at the evaporator to ensure adequate cooling of air in cellar.

Sub Cooling

- A. Measure head pressure at liquid line king valve. Convert pressure to temp using conversion chart.
- B. Temp of liquid line at king valve:
- C. Complete sub cooling calculation: $A - B =$

Superheat

- A. Measure suction pressure at the suction line service valve, convert to temp.
- B. Measure the temperature of the suction line at the outlet of the evaporator.
- C. Complete superheat calculation: $A - B =$
NOTE: There may be a need to adjust the TXV to get the correct superheat levels.

Compressor Temperature

- A. Measure temperature at bottom of compressor.
NOTE: Cool temp may indicate liquid in the compressor.

Voltage and Amp Draw

- A. Measure voltage to compressor and amp draw.

Condensation Drain Test

- A. Pour water into the drain pan to assure it drains properly.

ITEMS TO ROUTE BEFORE INSTALLING THE EVAPORATOR UNIT

1. Route the line set from the condensing unit to the desired evaporator unit installation location.
2. Route the display cable from the desired location to the evaporator installation location (see page 16 for more display information).
3. Route the bottle probe cable from the desired thermostat bottle location to the evaporator unit installation location (see page 15 for more bottle probe information).
4. Route the drain line from a proper discharge location to the evaporator unit installation location (see page 14 for more drain line information).
5. Route the power cable wiring to the evaporator unit installation location.

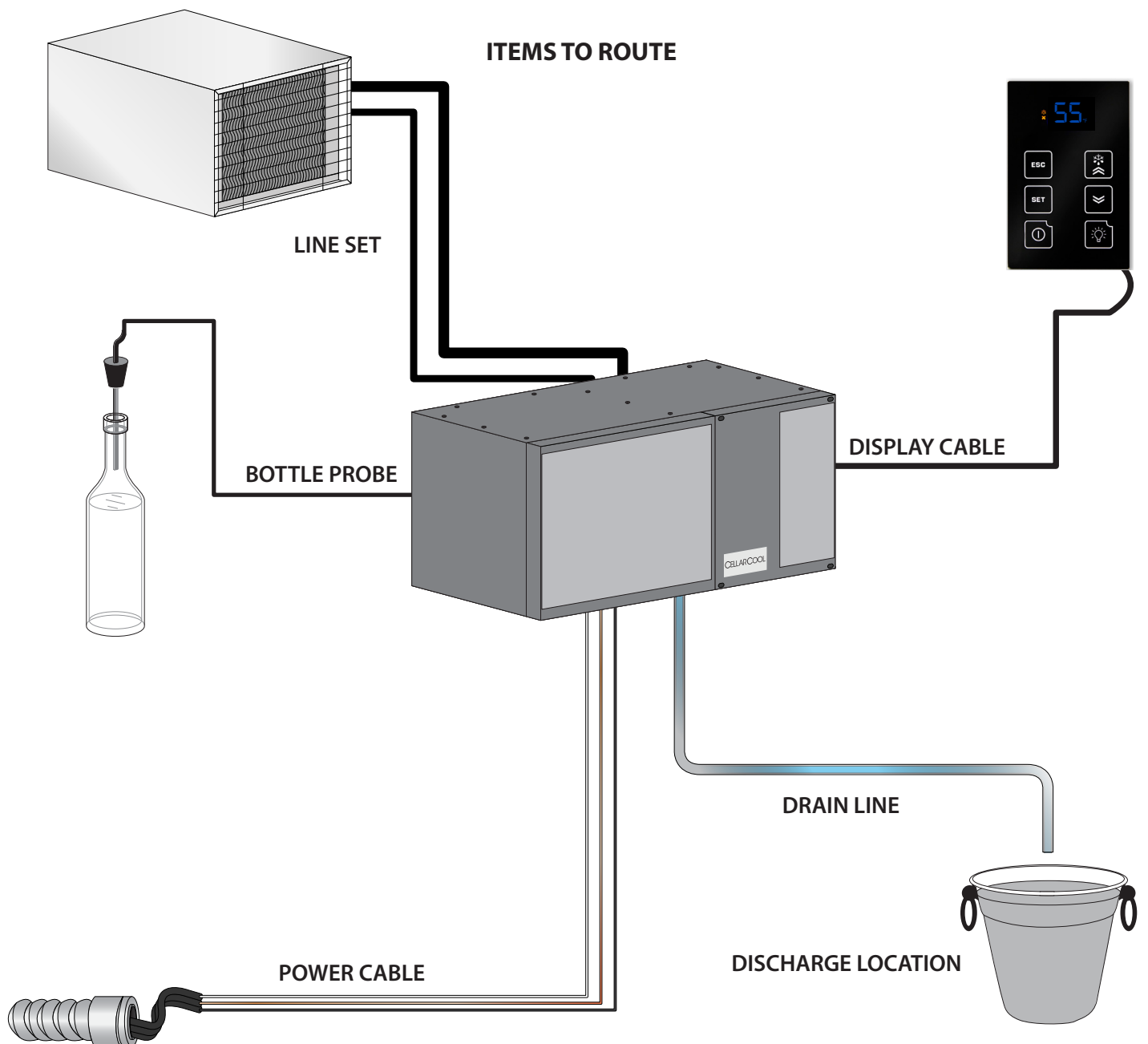

PREPARING AND INSTALLING THE EVAPORATOR UNIT

Required Tools:

- Drill
- $\frac{5}{32}$ " drill bit
- $\frac{1}{4}$ " socket drill bit
- $\frac{1}{4}$ " wrench
- Phillips-head screwdriver
- Tape measure
- Brazing torch
- Drywall saw
- Ladder
- Level
- Pliers
- Pencil

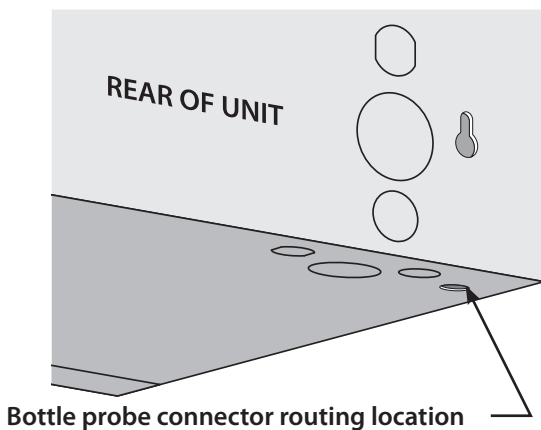
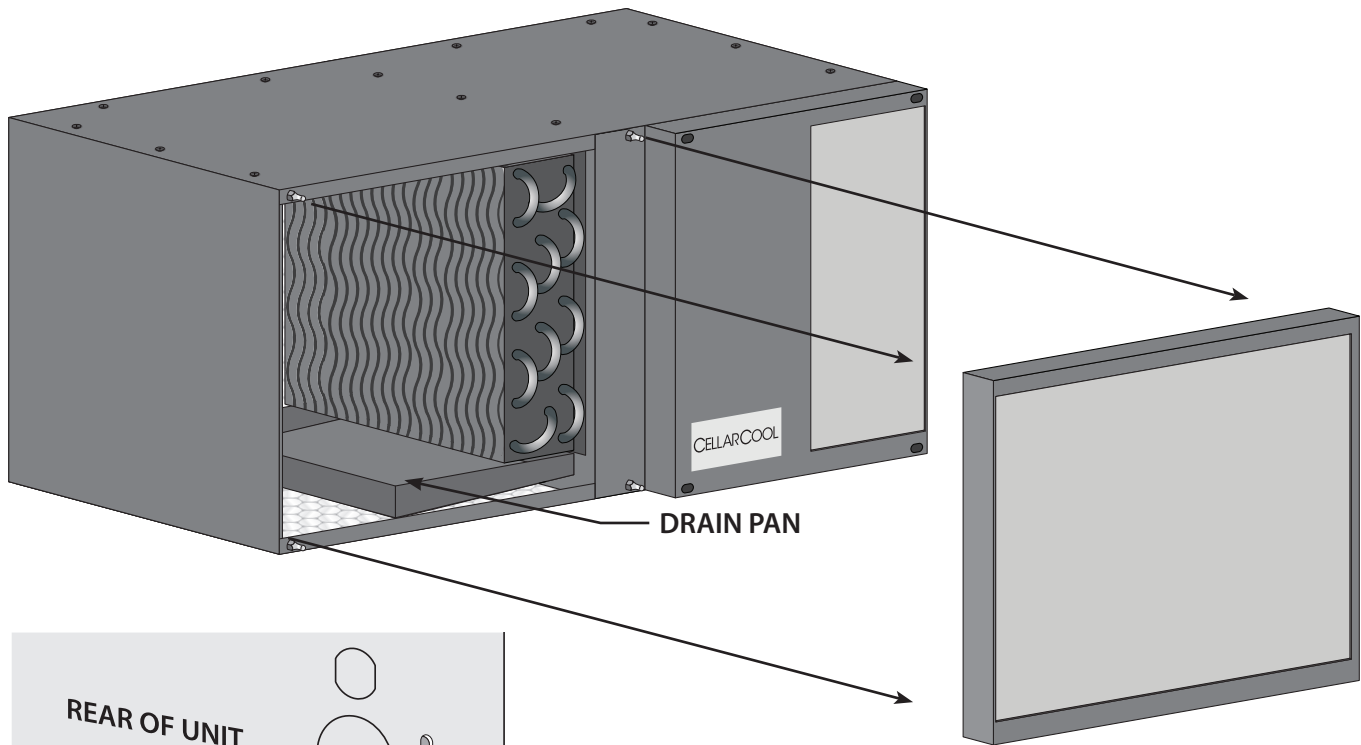

1. Pull the filter grille away from the evaporator unit.
 2. Cut the zip tie holding the circular connectors and wires on the rear left corner of the interior of the unit.
 3. Unscrew the nut attached to the circular connector (bottle probe input.)
 4. Install the circular connector (bottle probe input) in the hole located at the bottom of the housing.
- NOTE:** From a frontal perspective, the circular connector is located in the rear left corner of the bottom of the unit.
5. Secure the circular connector (bottle probe input) to the unit using the provided nut. The rubber washer should remain inside the unit.



Power

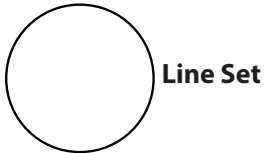

Line Set



Drain

6. Depending on the desired installation, remove the rear or bottom knockouts for the line set, drain line, and power cord.

7. Using a $\frac{5}{32}$ " drill bit, and drilling from the outside of the unit, cut holes through the unit's insulation for the line set and drain line.

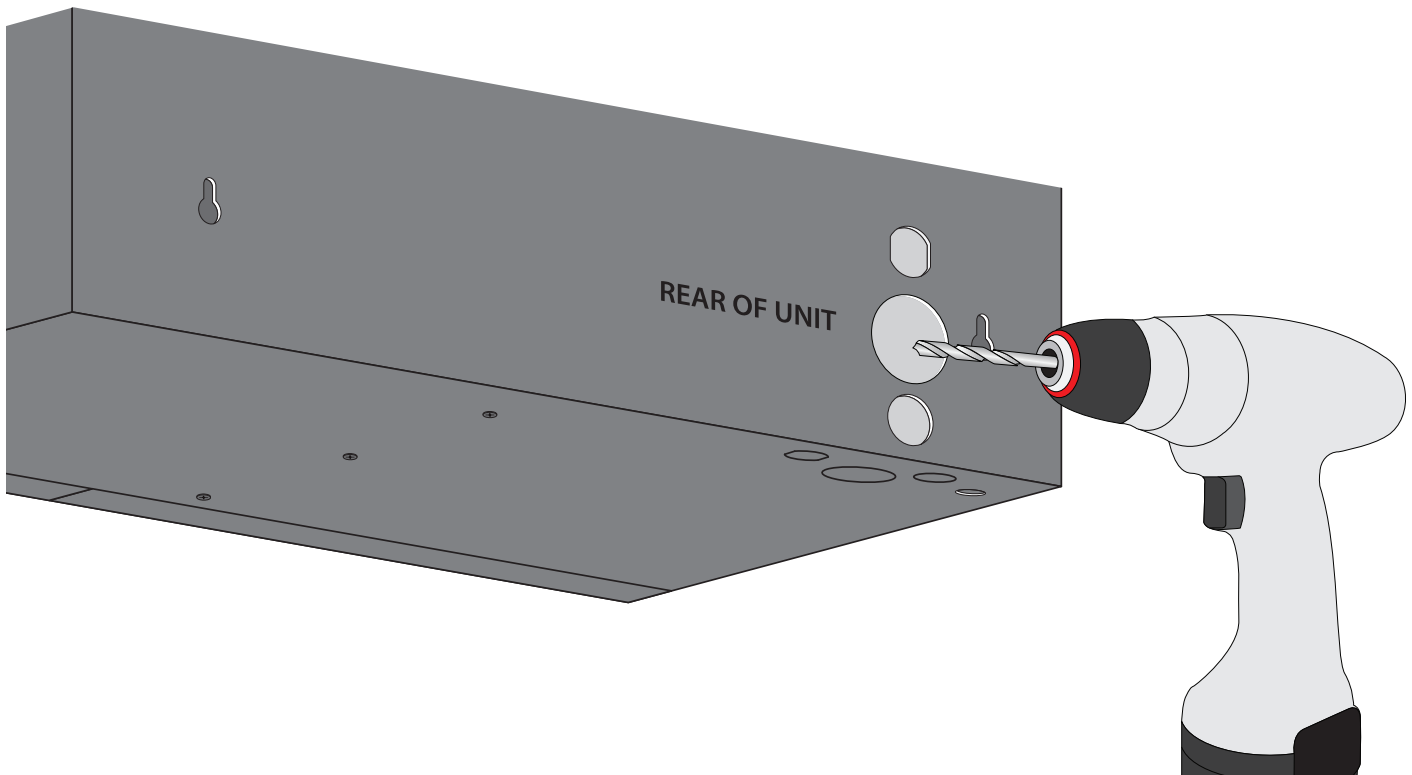

INSTALLING THE EVAPORATOR UNIT

Note: The evaporator is designed to be mounted on two standard wall studs spaced 16" apart.

1. Locate two (2) wall studs in the desired mounting location.

2. Mark vertical lines on each stud 16" apart.

Note: The top of the unit must be installed a minimum of 6" and a maximum of 18" from the ceiling.

3. Mark an intersecting horizontal line at the desired height of the unit.

4. Place the installation template on the wall, lining up the vertical lines through the sight slots.

5. With a pencil, mark the mounting screw holes and draw a location for the access hole on the installation template.

6. Set installation template aside.

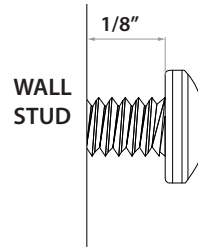

7. Install the supplied four (4) 2" #8 hex head screws at the locations marked, leaving 1/8" between the wall surface and screw head.

8. Cut out an access hole for the line set, drain line, display cable, and power wires. Be sure to clear the hole of all debris and insulation.

9. Raise the evaporator to the installation location. Align the rear keyholes with the mounting screws and mount the unit.

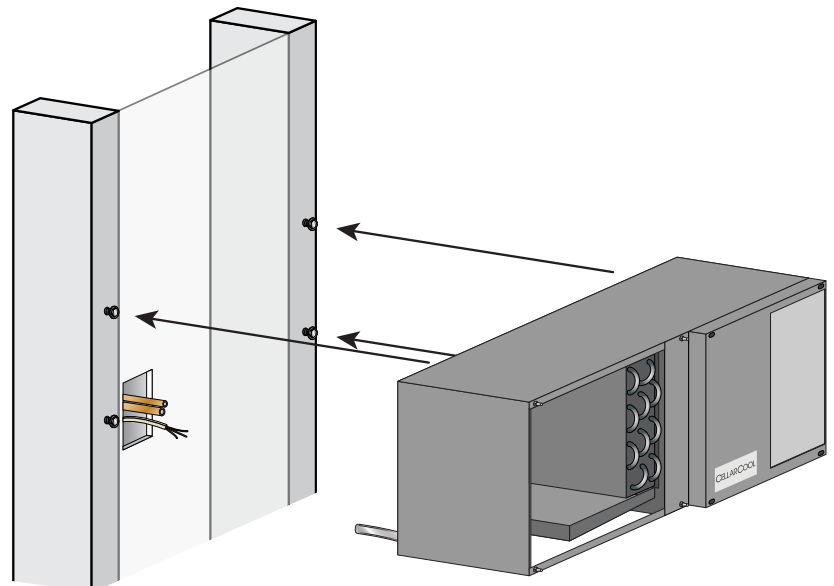
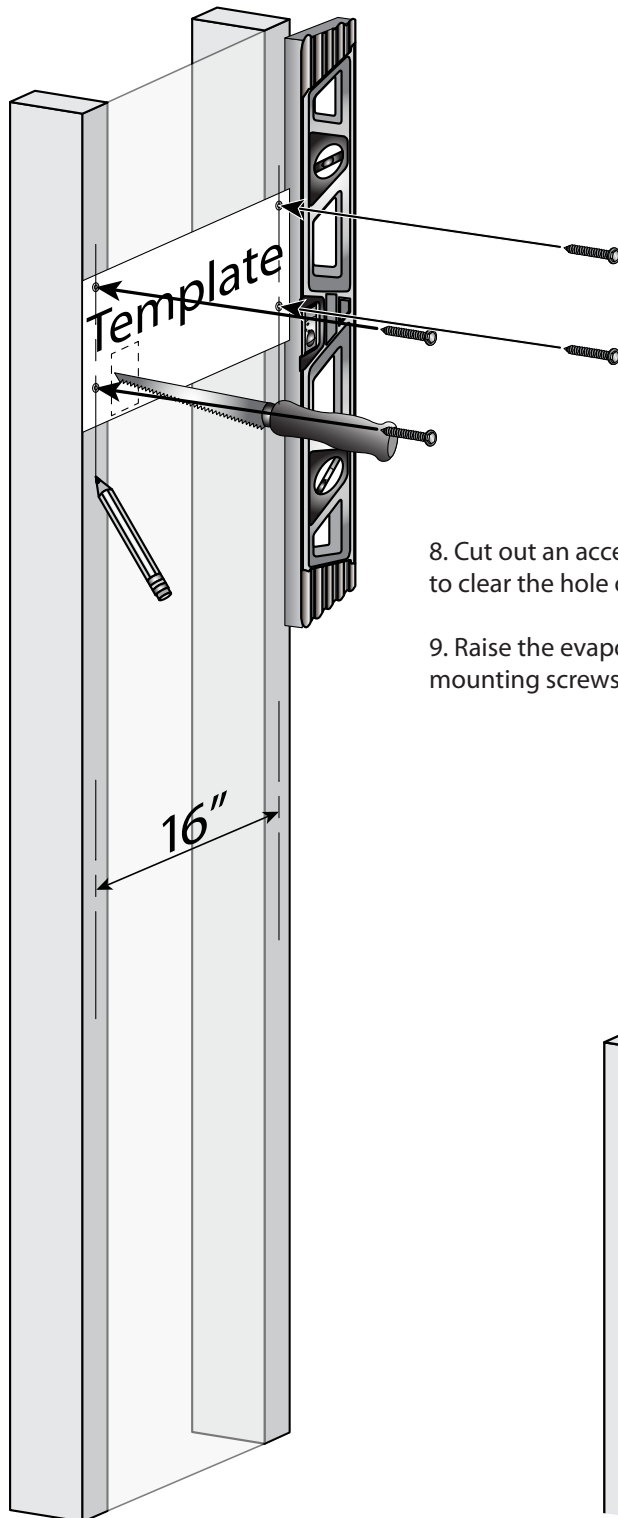

10. Using a ¼" wrench or socket, tighten the accessible mounting screws on the left-hand side of the interior of the unit.

Note: For ease of installation, remove the top panel after securing unit to wall.

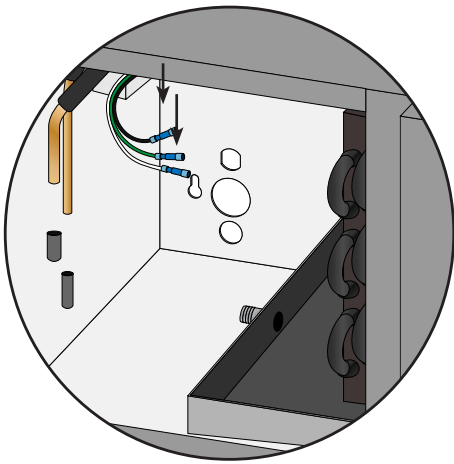
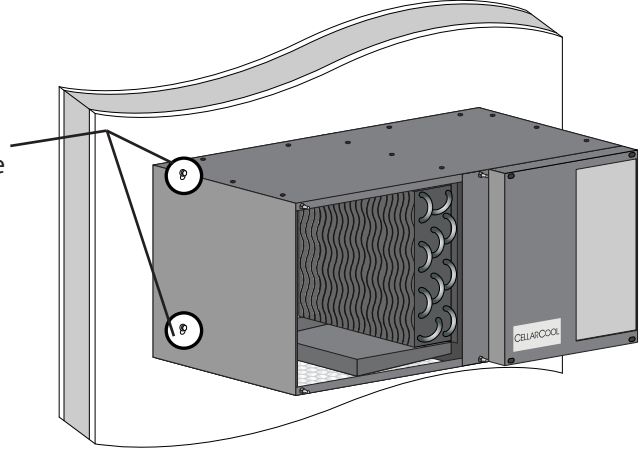

11. Remove the line set caps. Route the 3/8" suction line and 1/4" liquid line into the unit and braze.

Note: Angle the flame up and away from any electrical lines and insulation while brazing inside of the unit.

12. Route power supply wires into the unit through the power knockout and install the supplied strain relief.

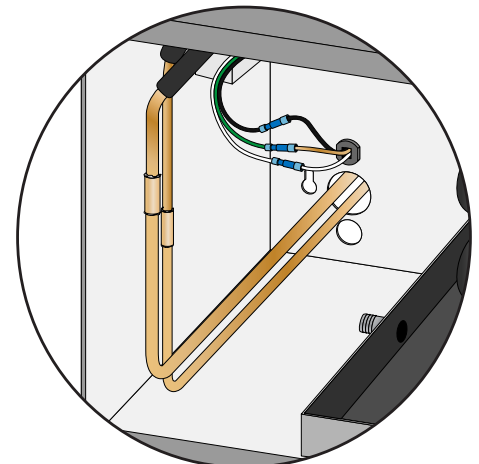
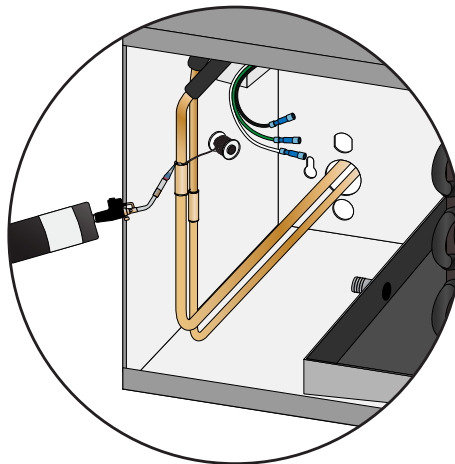

13. Connect power supply wires to the pre-installed butt splice connectors located inside of the unit (hot=black, neutral=white, ground= green).

14. After the suction line has been insulated, connect the bottle probe. (See **Figure 1.**) Secure loose bottle probe cable with cable ties.

Note: Reinstall top panel if you removed it earlier.

15. Reinstall the access panel removed in Step 1 on page 10 by pushing the four corners into place. (See **Figure 2.**)

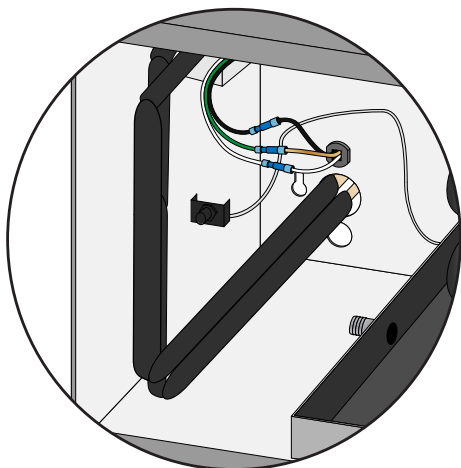

Figure 1

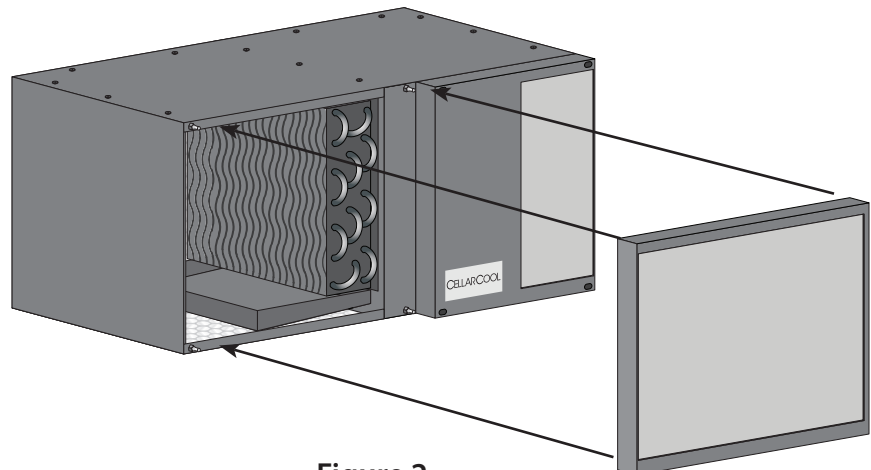

Figure 2

DRAIN LINE

Condensation Drain Line (not provided, but required)

The condensation drain line tube moves excess condensation from the evaporator unit to a proper discharge location. It is important for the drain line tube to be properly connected in order to prevent leakage and other problems associated with excess condensation.

Failure to use the condensation drain line tube will void the warranty on the unit.

Drain Line

All systems come with a drain line connection tee and two 90-degree fittings. The unit is equipped with a 1/2" OD barbed fitting coming from the drip tray. (**NOTE:** 1/2" ID clear PVC tubing will need to be purchased and installed by the installing technician.) Installation of the drain line is mandatory, whether it leads through the wall and out of the cellar or remains inside the cellar. During operation, the cooling system will strip excess water from the air in order to maintain the proper level of humidity within the cellar. However, in extreme humidity, additional condensate will be removed; thus the drain line will prevent overflow and leakage by discharging the excess condensate.

Routing the tubing out of the unit:

Cut a small piece of 1/2" tubing and connect one end to the drip tray port and the other to a 90-degree fitting. (This will direct the tubing toward the back of the unit where the tube will exit the unit.) Be sure to extend the tubing far enough outside the housing to extend through the wall if necessary.

If routing out of the rear: Cut a piece of tubing long enough to protrude out of the knockout in the back side of the unit.

If routing out of the bottom: Cut a piece of tubing long enough to reach the knockout in the bottom of the unit and install the supplied 90-degree fitting. (This will direct the tubing out of the bottom of the unit without the risk of kinking the tubing.) **DO NOT USE TEE WHEN ROUTING OUT OF THE BOTTOM.**

Routing to discharge location if routed out of the bottom:

Connect the drain line directly to the second 90-degree barb fitting previously installed. Route the drain line to an appropriate drain location. No tee is required if draining through the bottom of the unit.



WRONG: Drain line is under water.

Routing to discharge location if routed out of the rear:

Insert the middle barb of the barbed tee fitting into the end of the drain line coming from the evaporator. Rotate fitting so tee is in the orientation shown in the diagram below. Connect a 3-inch piece of 1/2" drain line to the barb on top. Connect the remaining "long" piece of drain tubing to the bottom barb of the tee. Route the drain line to an appropriate drain location.

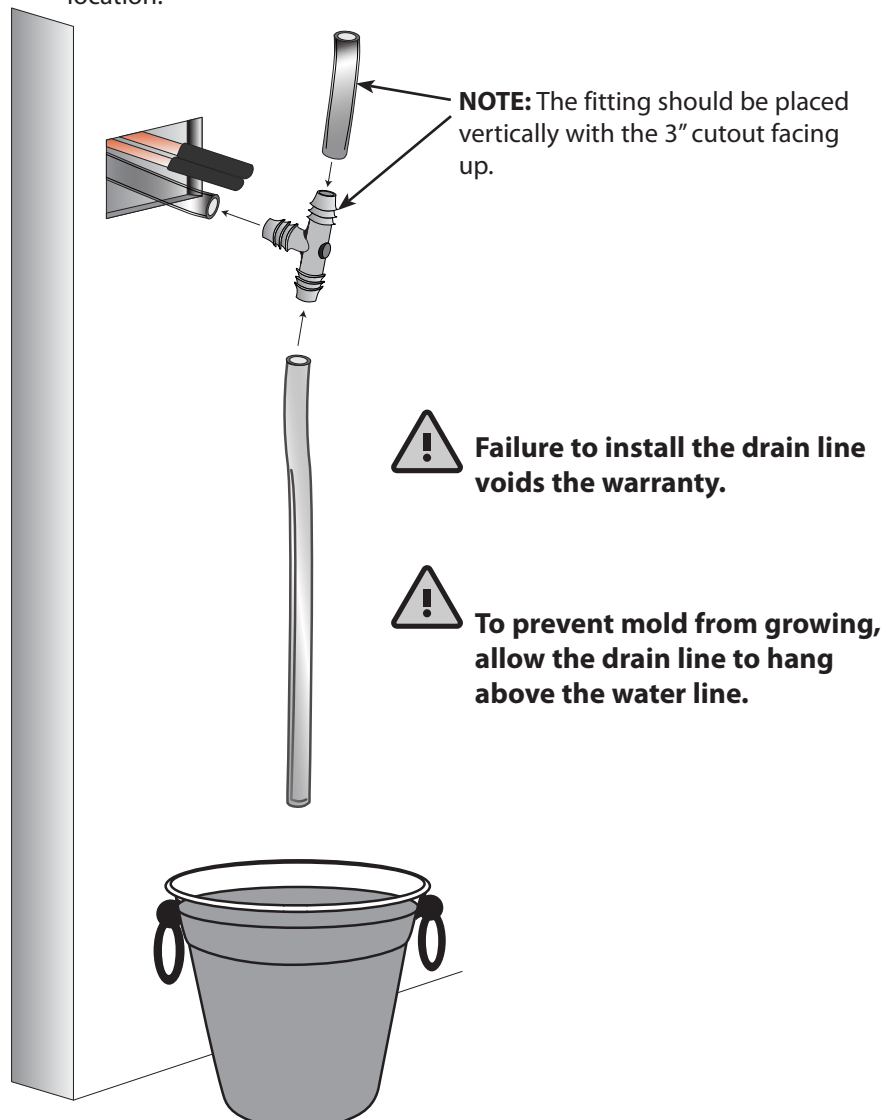

LIQUID-MEASURING THERMOSTAT SYSTEM (BOTTLE PROBE)

CellarCool cooling units come with a liquid-temperature-measuring thermostat. The self-calibrating probe contains a sensor chip, which communicates back and forth with the thermostat. This results in a consistent temperature setting and accuracy. Wine should be kept at a very precise, controlled temperature and humidity. By measuring the liquid temperature rather than air, the unit will operate 75–80% of the time.

Setting up the Bottle Probe:

1. Locate an empty wine bottle.
2. Fill it 75% full with room-temperature tap water.
3. Place bottle probe securely into bottle as seen in Figure 1.
4. Place bottle off to the side of the unit in your wine cellar, with the probe level.
5. To ensure a consistent temperature, place bottle probe approximately three (3) feet away from the air output and not in the flow of the air.

It is recommended that the bottle be placed in a central location of your wine cellar. Avoid pulling too much on the probe cord. It may become disconnected resulting in limited functionality of the unit.

Note: The thermostat can be set between 50–70°F.

Remember: The unit operates based on the temperature of the water.

Do not be misled by thermostats reading air temperature. The air temperature in the cellar will be cooler than the liquid temperature of the wine while it is reaching the optimum balanced temperature.

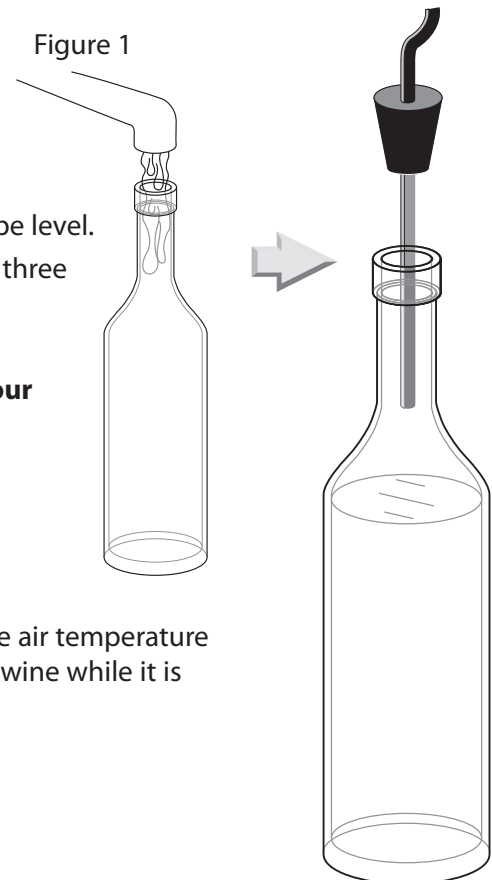

REMOTE DISPLAY: INSTALLATION AND CONFIGURATION

Tools needed: 5/16" drill bit, 3/16" drill bit, drywall saw, level, pencil

What's included: Display panel, wall mount bracket, flush mount bracket, flush mount template



Display panel

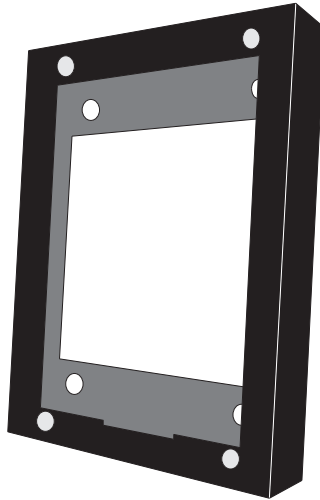

Wall mount bracket

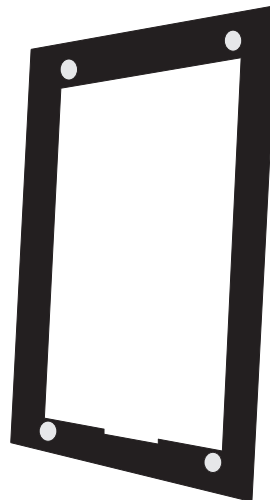

Flush mount bracket

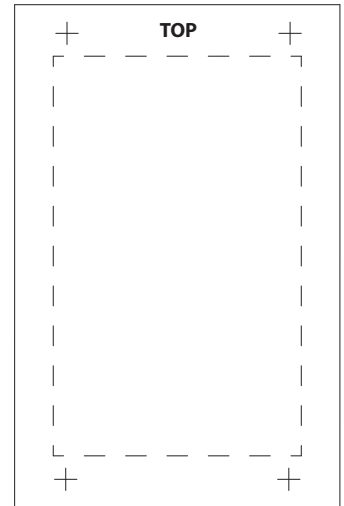

Flush mount template

WALL MOUNT BRACKET INSTALLATION

1. Place the bracket on the wall. Use a level to ensure that the bracket is level. Using a pencil, mark the four screw holes in the rear of the bracket.

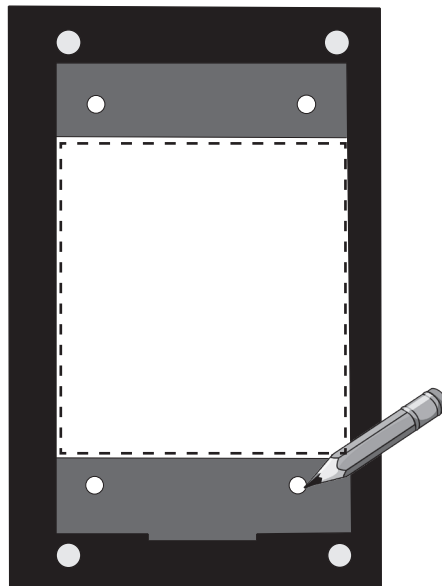

NOTE: Cut hole in the location shown for routing the display cable.

WALL MOUNT BRACKET INSTALLATION, CONTINUED

2. Using a drill with a $\frac{3}{16}$ " bit, drill four holes in the drywall for the screws. Insert the four (4) provided drywall anchors into the drywall, then tap them in with a hammer until they are flush with the wall.

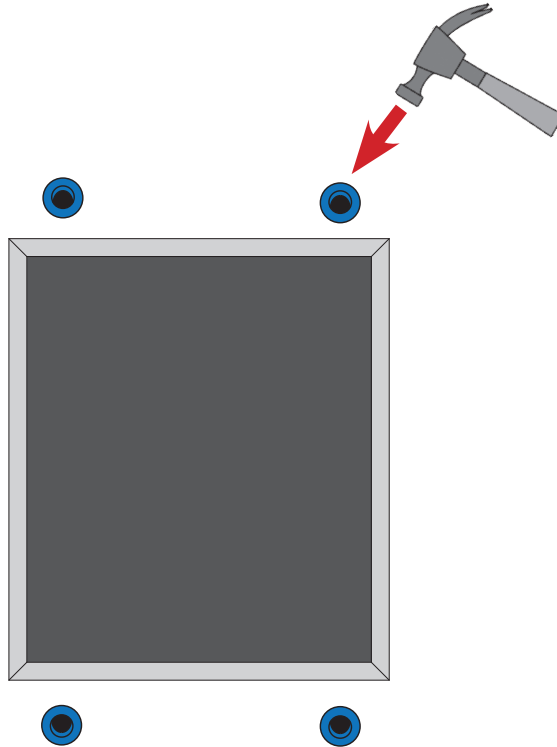

3. Place bracket against wall, aligning screw holes with drywall anchors. Insert the four supplied Phillips-head screws into the drywall anchors. Tighten the screws to secure the bracket to the wall.

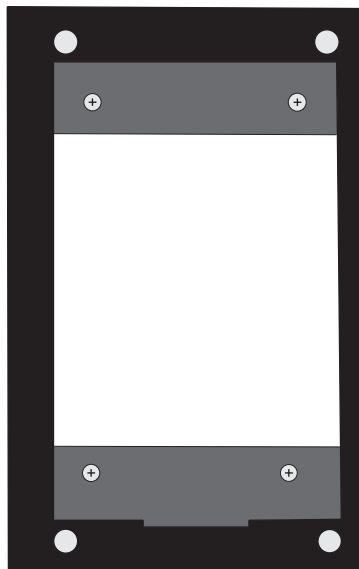

WALL MOUNT BRACKET INSTALLATION, CONTINUED

NOTE: Before you continue to Step 4, locate the area where the display will be mounted. You may route the display wire into the housing one of three ways: either through the wall or through one of the holes on the top or bottom edges of the wall mount bracket. If you'd like to route the display cable through one of these holes, place a rubber grommet into the hole and then route the display cable through the grommet and into the wall mount bracket.

4. Connect the end of the display cable labeled “**DISPLAY**” to the JST connector on the back of the display.

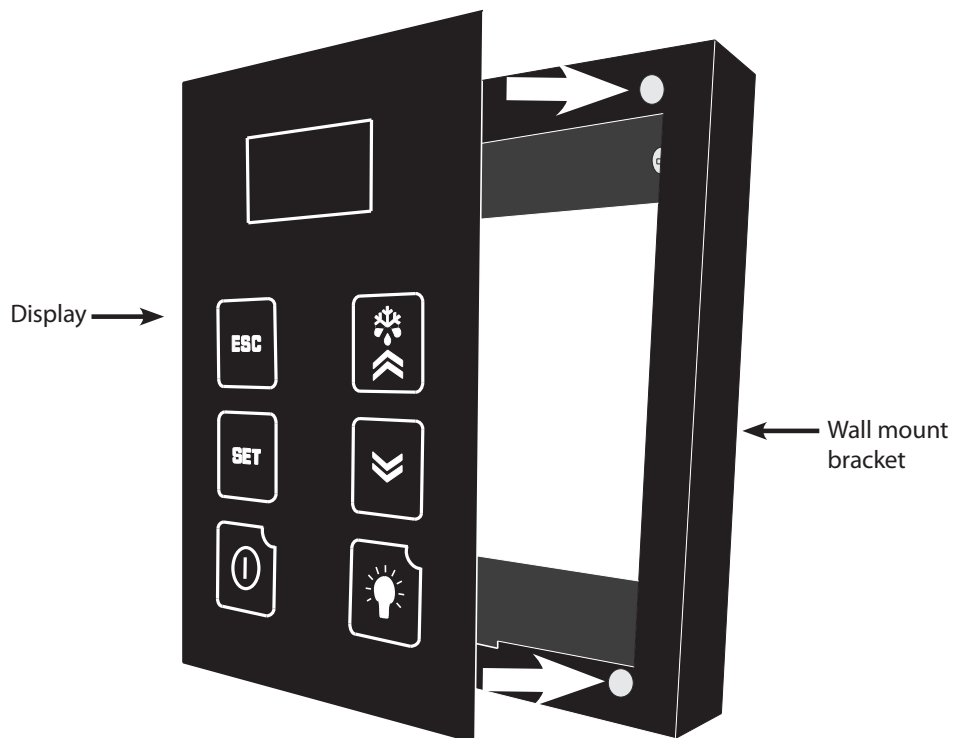
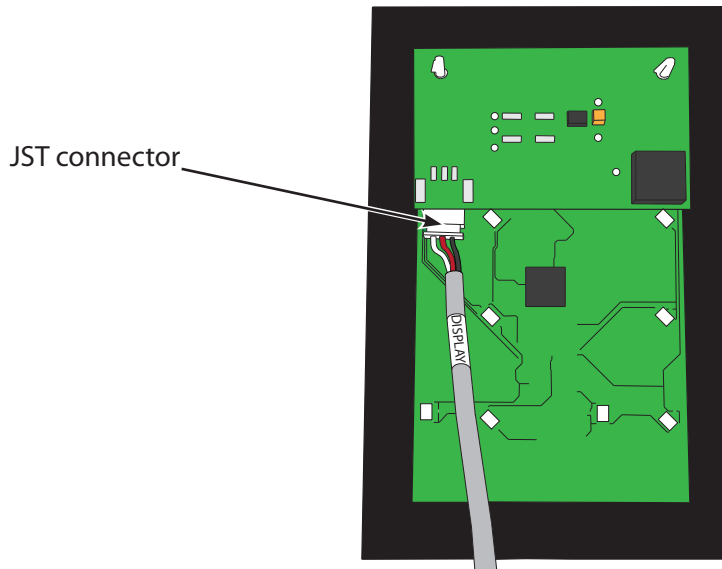

5. Place the display on the wall mount bracket as shown, attaching the back of the display panel to the magnets on the mounting bracket. Make sure that the alignment tab on the back of the display panel sits in the notch on the bottom of the bracket.

FLUSH MOUNT BRACKET INSTALLATION

1. Square the flush mount template on the wall using a level. Then draw a 3" line along the bottom edge of the template.

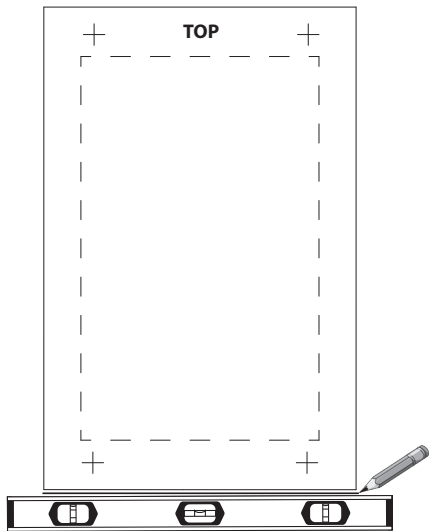

2. Peel the backing off the template and stick it to the wall, aligning the bottom edge with the line drawn in Step 1.

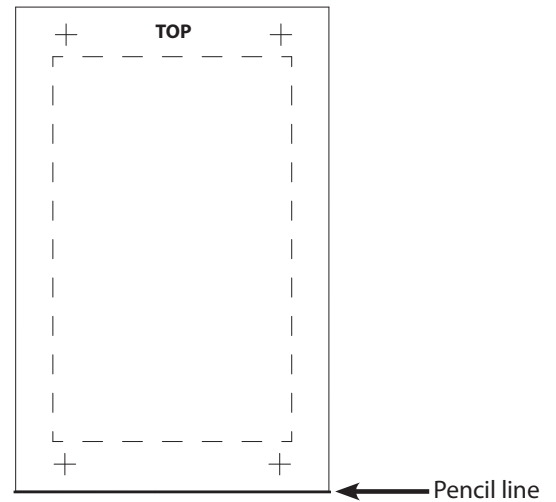

3. Use a $\frac{5}{16}$ " drill bit to drill a hole in the center of each cross (+).

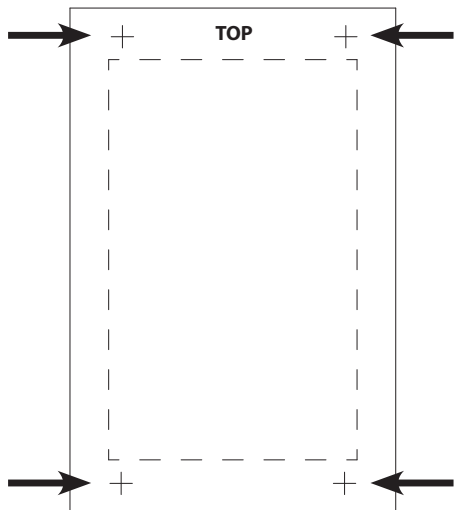

4. Cut along the perforated lines. When finished, remove template from wall.

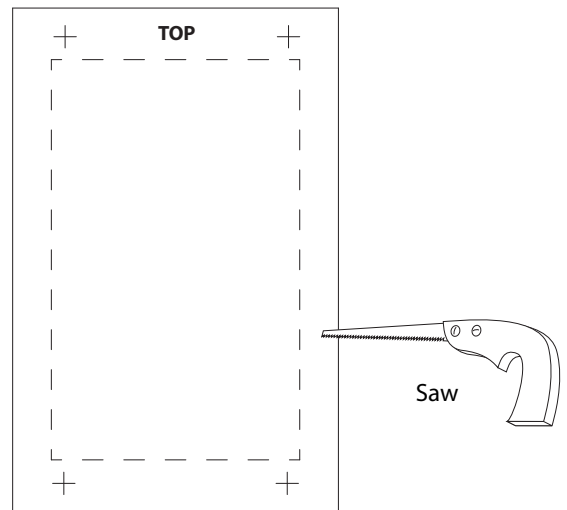

FLUSH MOUNT BRACKET INSTALLATION, CONTINUED

5. Remove the backing from the double-sided tape on the flush mount bracket.

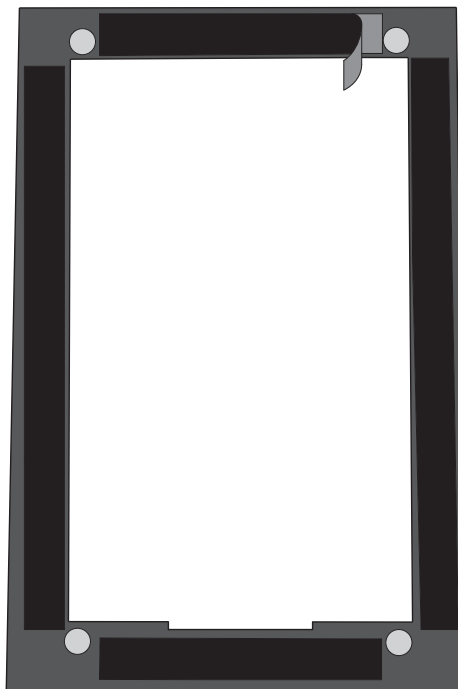

6. Align magnets with previously drilled holes. Make sure the cut-out portion of the bracket (circled below) is on the bottom. Press the bracket firmly against the wall.

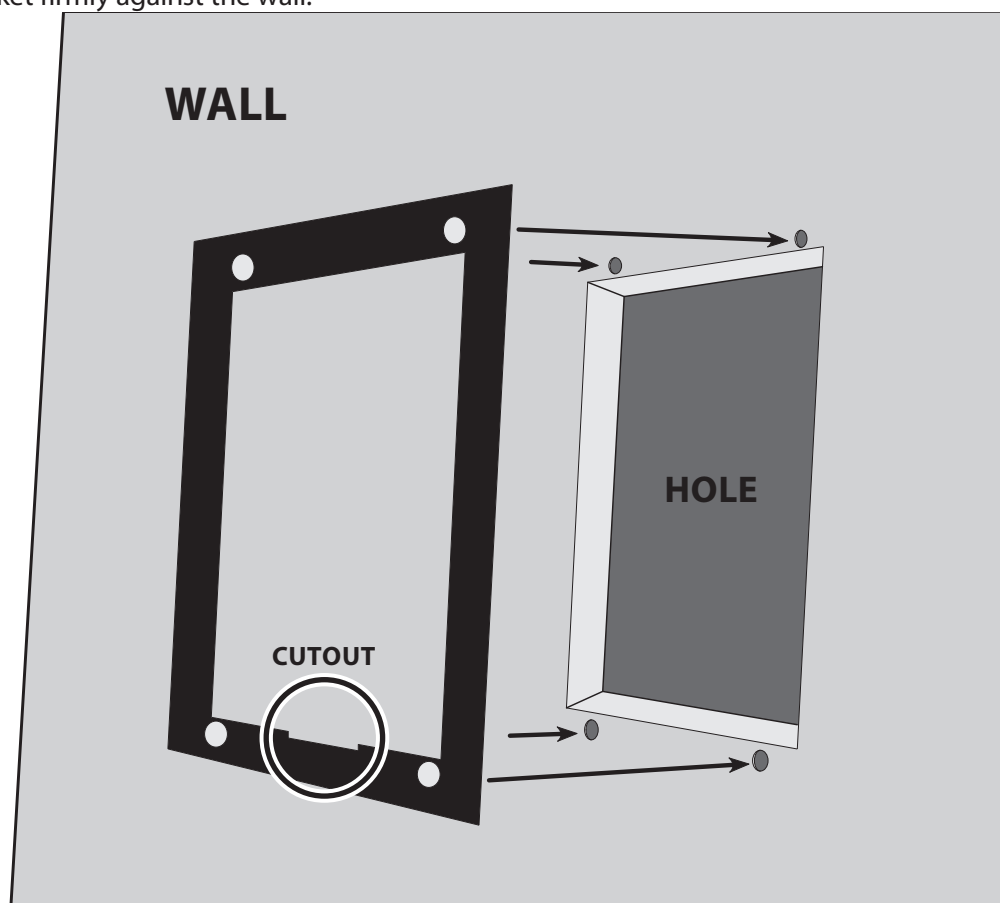

FLUSH MOUNT BRACKET INSTALLATION, CONTINUED

7. Connect the end of the display cable to the JST connector on the display panel.

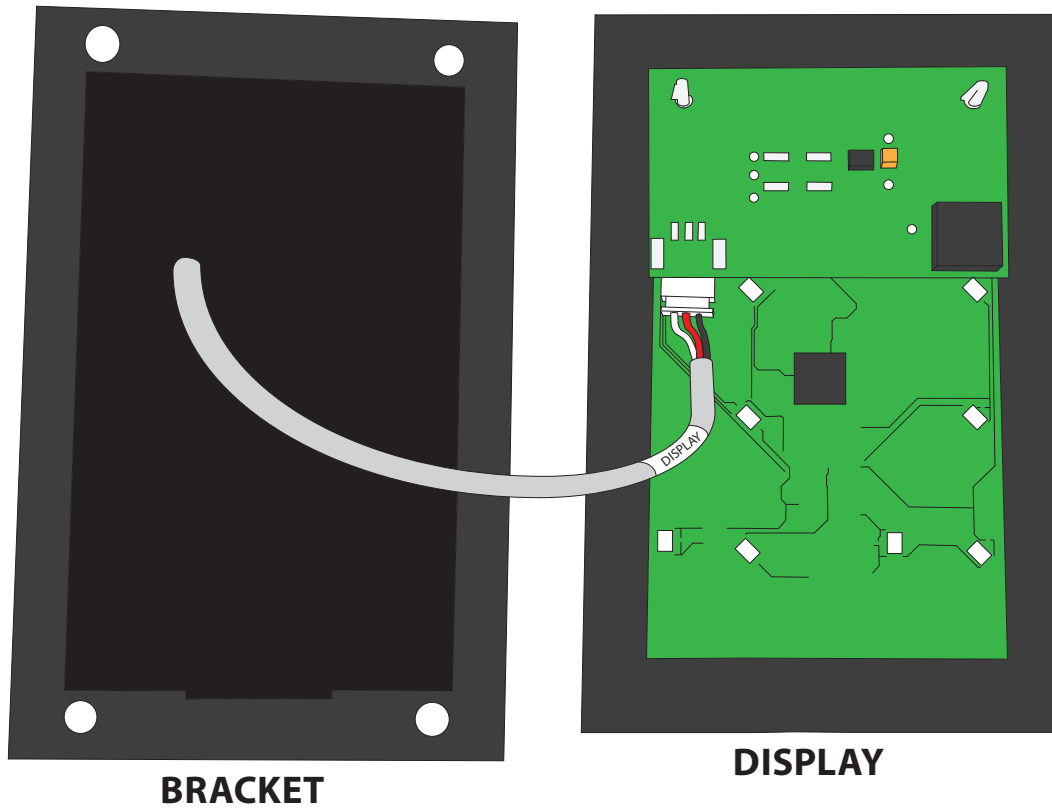

8. Place the display on the flush mount bracket as shown, attaching the back of the display panel to the magnets on the mounting bracket. Make sure that the alignment tab on the back of the display panel sits in the notch on the bottom of the bracket.

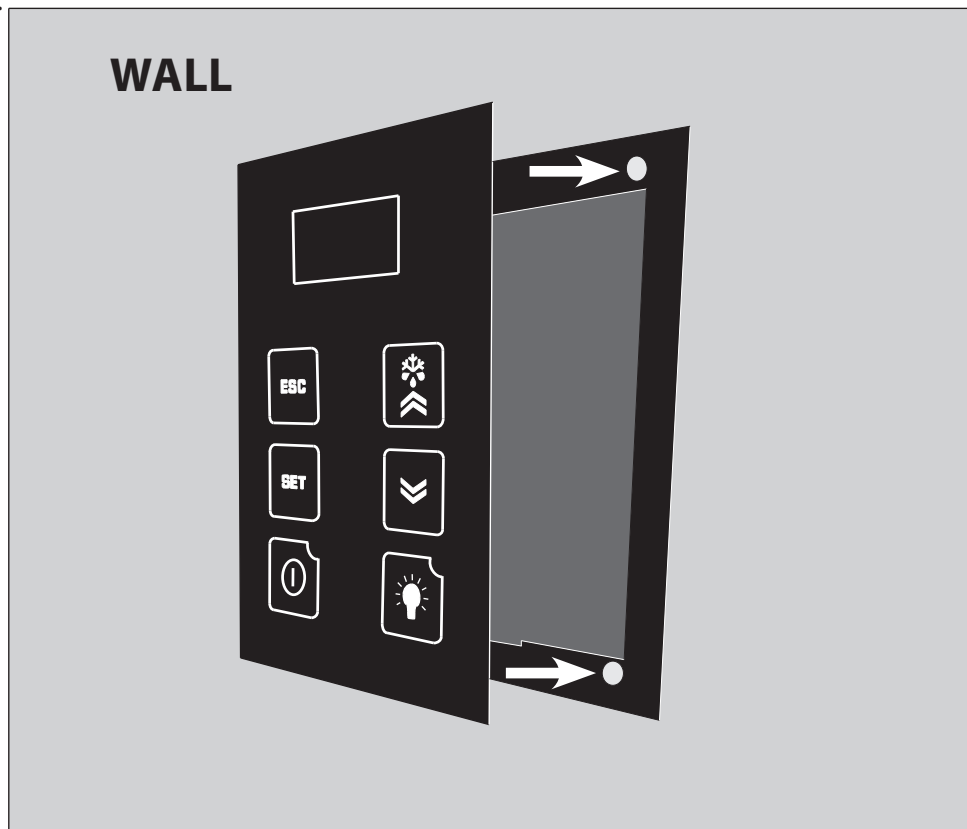

PREPARING THE CONDENSING UNIT

Electrical Needs

The condensing unit requires a dedicated 115V, 15-amp circuit. The unit draws a large inrush current for about 1 second the instant the compressor starts. With a dedicated circuit and circuit breaker, the condensing unit will have sufficient power for effective operation. (The compressor is controlled by a low-pressure transducer mounted on the condensing unit. This feature eliminates the need for wiring between the evaporator unit/fan coil unit and the condensing unit.)

- Ensure the voltage supplied matches the rating specified on the unit spec label.
- Provide a non-GFI dedicated circuit and an appropriate outlet for the evaporator unit.
- Provide a dedicated circuit and circuit breaker for the condensing unit.
- Provide a weatherproof disconnect for the condensing unit if it is located outside.

Power surges and spikes can damage sensitive electrical equipment. CellarCool recommends plugging the unit into a surge protector or power conditioner in order to protect your system. As outlined in our terms and conditions, power surges and spikes are not covered under warranty.

WE RECOMMEND THAT YOU DO NOT USE A GROUND FAULT INTERRUPTER (GFI) WITH THIS PRODUCT.

In case the system should lose power, check the home/main circuit breaker. If the system does not respond properly, refer to the Troubleshooting Guide on page 42.

WM 2500 EVAPORATOR UNIT WIRING DIAGRAM

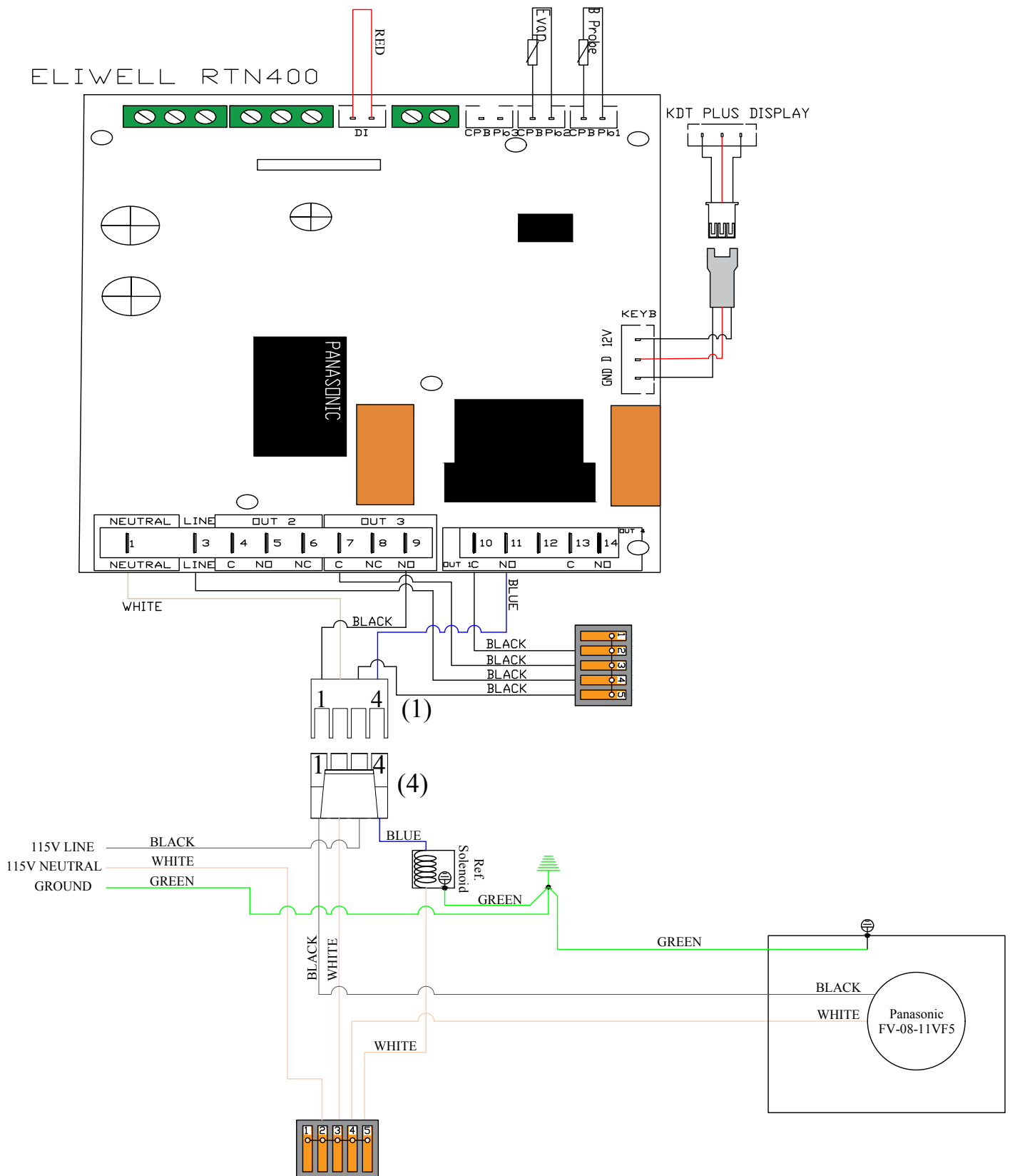

WM 2500 CONDENSING UNIT WIRING DIAGRAM

For systems manufactured after October 31, 2018

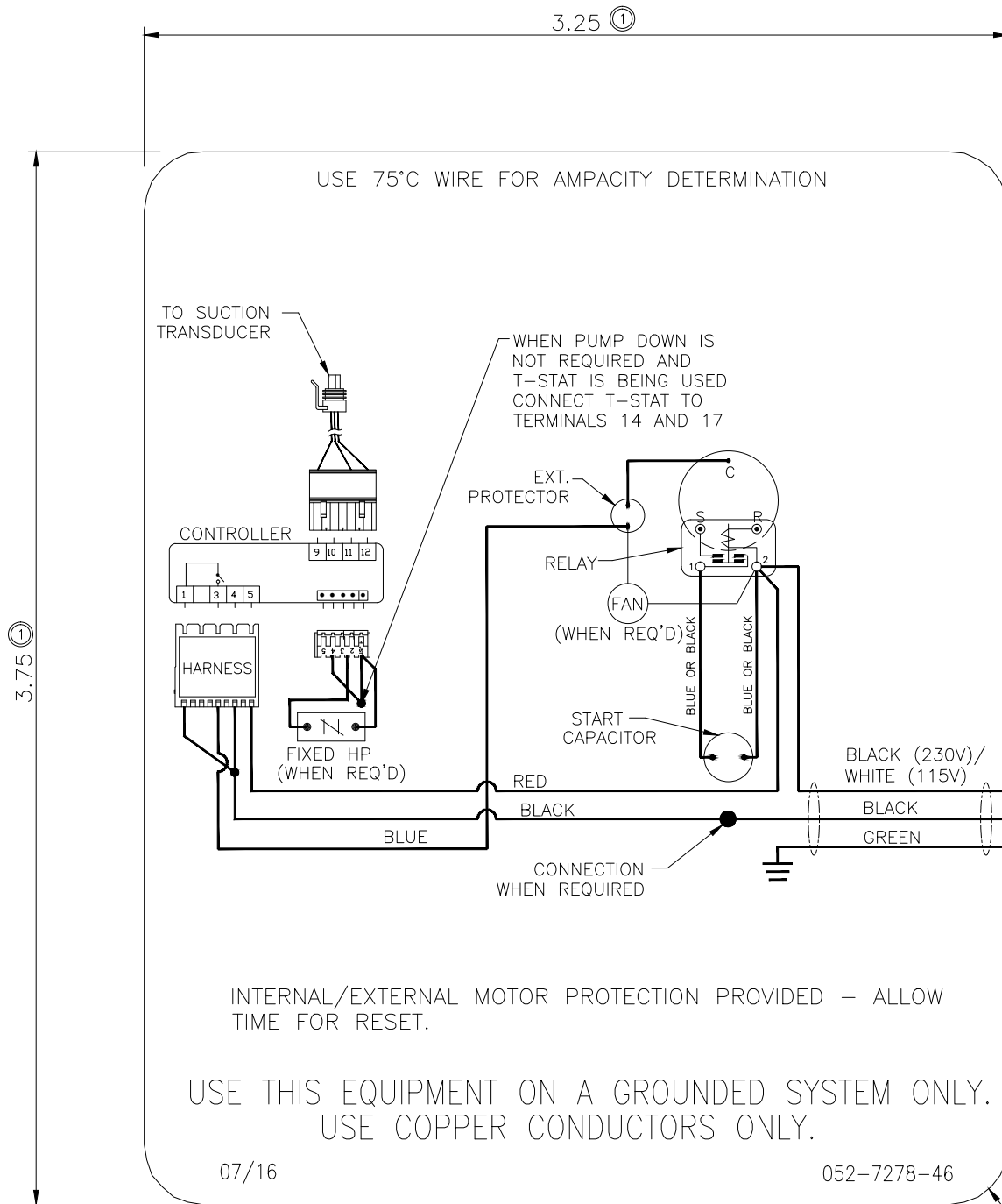

ROUND OR SQUARE CORNERS

COPELAND COLD WEATHER START KIT WIRING DIAGRAM

For systems manufactured after October 31, 2018

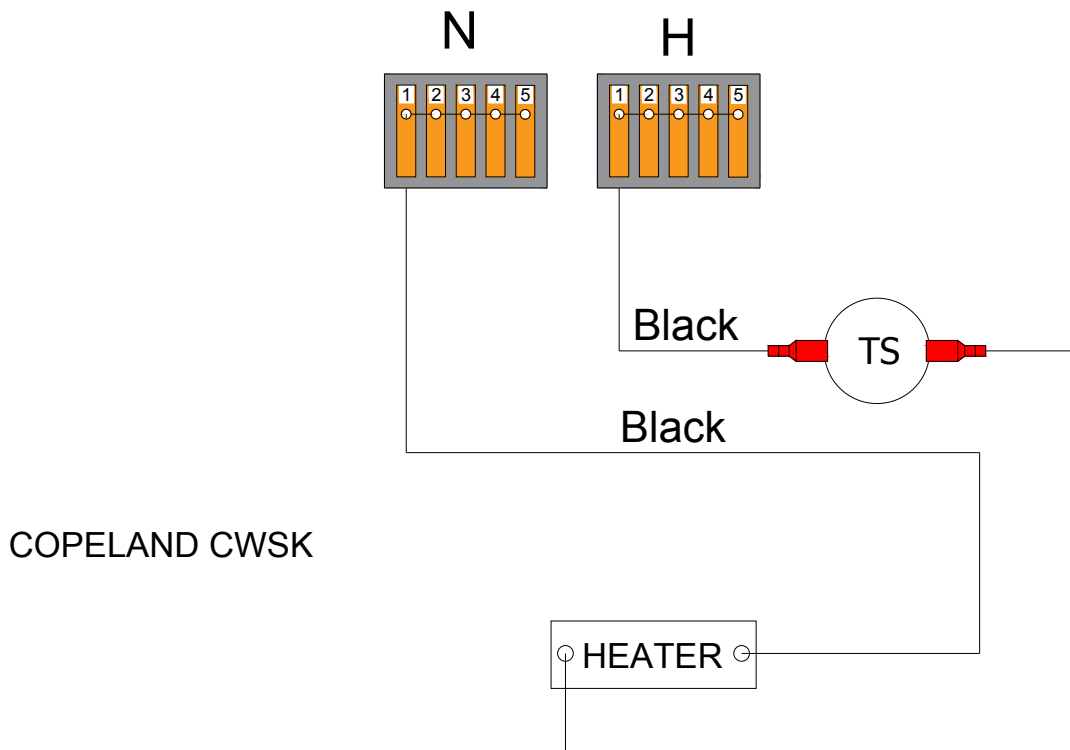

COPELAND CWSK

INSTALLING THE CONDENSING UNIT

The condensing unit can be installed inside a well-ventilated area of the home, but is typically installed outside. Exterior applications will require the use of a protective housing. The amount of sun exposure should be considered when selecting the placement of the condensing unit. The condensing unit requires a dedicated 15 -amp circuit (non-GFI). **Make sure there is a minimum of three (3) feet of horizontal clearance in every direction around the unit (five feet is ideal).** The unit should be plugged in.

Ensure that the condensing unit is level and has the proper amount of clearance outlined in the instructions. Also make sure you have the name plate power supplied, proper electric disconnect, and fuse protection connected but not turned on and ready for piping connections.

Indoor condensing unit installations:

Inside installations require special consideration, as there must be adequate ventilation to remove the heat created during normal operations. An exhaust port with fan may need to be installed to ensure that heat is effectively removed from the utility room. There must be a return grille or provision for 500-600 CFM of cool air to enter the room to replace the exhausted air. Unobstructed airflow to and from the unit is a critical factor in the unit's overall performance. **Make sure there is a minimum of three (3) feet of horizontal clearance all around the unit (five feet is ideal).** This will assure that the unit can move the air around the room in an efficient manner.

Outdoor condensing unit installations: You must utilize the exterior condensing unit housing for outdoor installations. Place the condensing unit on a solid foundation in a location with adequate ventilation. **Make sure there is a minimum of three (3) feet of horizontal clearance in every direction around the unit (five feet is ideal).** The unit should be elevated 18 inches in order to avoid any possible flooding or damage by animals, and should be clear of leaves, dirt, and other debris.

Refrigeration Lines:

A ¼" OD copper liquid line is required.

Model	Line Set Length	<25ft			26-50ft			50-100ft		
		<3ft	3-10ft	>10ft	<3ft	3-10ft	>10ft	<3ft	3-10ft	>10ft
WM 2500	Horizontal Tubing	3/8"								
WM 2500	Vertical Rise	3/8"								

The refrigerant drier and the sight glass shall be installed (in that order) in the direction of the refrigerant flow in the liquid line between the condensing unit and evaporator unit. Enclose the suction line with Armaflex (½" wall thickness) or comparable insulation to reduce heat transfer.

LINE SET PIPING DIAGRAMS

These are two options for running the line set from the coil to the condensing unit. Option 1 is specifically applicable when the system is installed with the condensing unit below or leveled to the coil. Option 2 is applicable when the system is installed with the condensing unit at a higher elevation than the coil.

Option 1

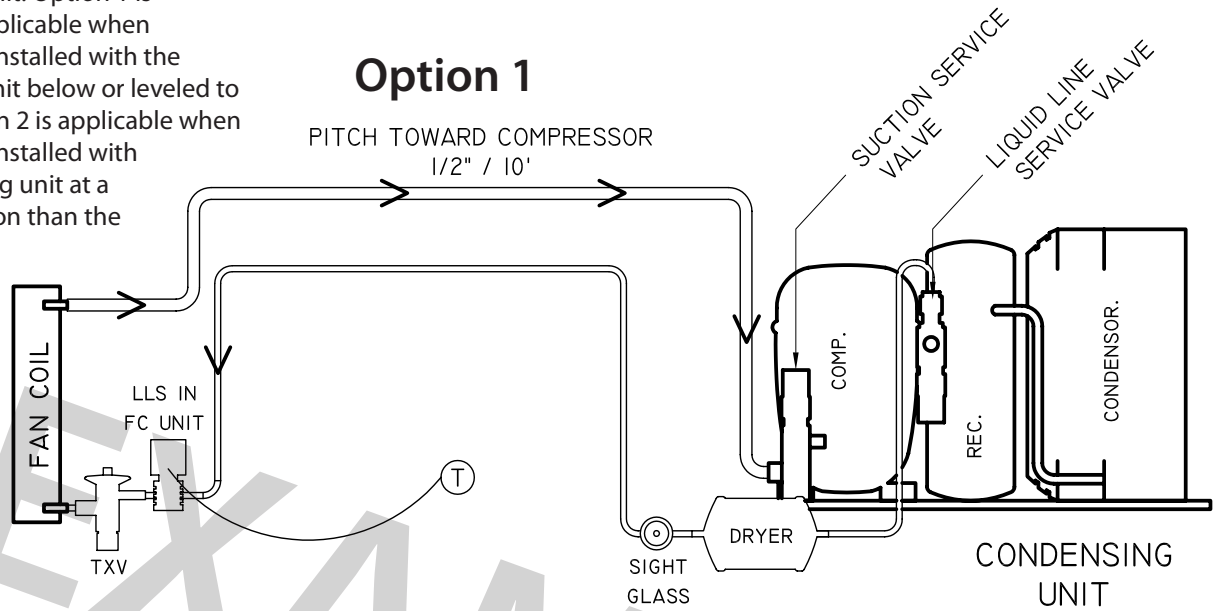

Option 2

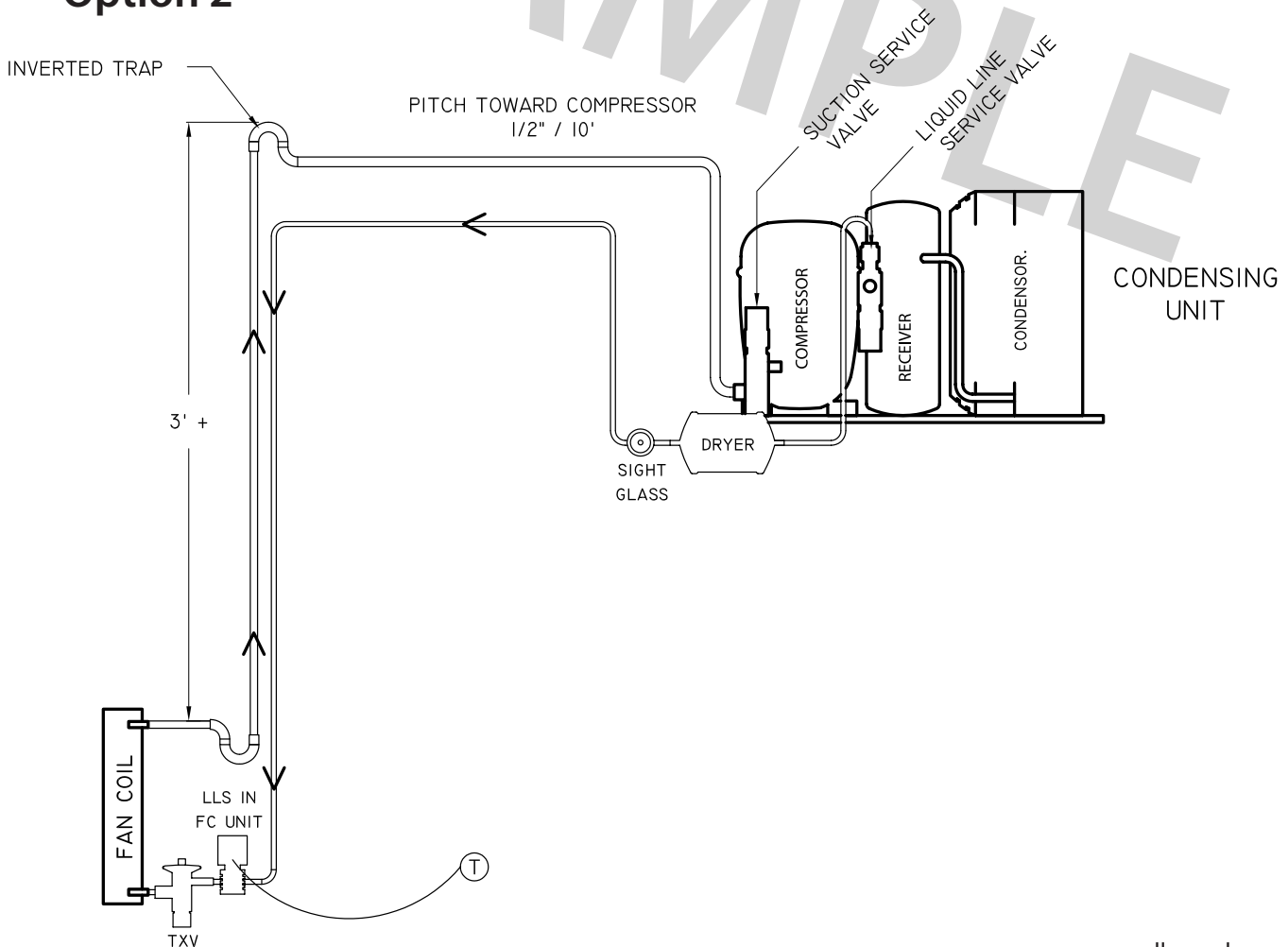

INSTALLING THE CONDENSING UNIT (continued)

DO NOT BLOCK airflow through the exterior housing. This will restrict airflow and void the warranty.

Refrigerant Piping Overview

- Using the charts and illustrations found above, route the line set between the evaporator unit and condensing unit. Be sure to reference the chart for correct line set sizing. All horizontal suction piping should be pitched toward the condensing unit half an inch for every 10 feet of pipe. When installing and routing the line set, cap both ends of each tube to prevent debris from entering the tubing.
- Prior to connecting the piping to the evaporator and condensing units, loosely connect a refrigerant manifold to the suction and liquid line service valves.
 - Purge the hoses with dry nitrogen and tighten the hose connections.
 - Remove the service valve caps and turn the valve stem clockwise half a turn to unseat the valve and open the service port. Keep the piping ports sealed until ready to braze.
- Purge the fittings with dry nitrogen at a slow rate to prevent formation of highly abrasive copper oxide.
- Perform all brazes.
- Pressure test the system and check for leaks.
- Insulate the suction line using wall cellular insulation or equivalent. Seal all seams with Armaflex 520 Foam Insulation Adhesive or equivalent. Wrap each seam using line set tape.

Liquid Line Piping Procedure

- Refer to the line set piping chart for liquid line size requirements.
- Braze a short piece of copper tubing to the liquid line service valve.
- Connect the supplied refrigerant drier to the tubing.
- Downstream from the drier, connect the moisture-indicating sight glass in an easily visible location.
- Run the tubing to the evaporator unit and attach to the liquid line connection on the evaporator unit.

Suction Piping Procedure

- Connect an appropriately sized suction line to the suction line service valve on the condensing unit.
- Run the pre-insulated suction line to the evaporator unit and attach to the suction line connection on the evaporator unit.

Brazing Procedure

- Connect the bottle probe to the evaporator unit.
- Fill a wine bottle 75% full of room-temperature water. Insert the bottle probe into the neck of the bottle as far as possible. It is important that the bottle probe stopper be compressed by the neck of the bottle to ensure water will not leak.
- Energize the evaporator unit and set the controller to call for cooling.
- Verify that the setpoint on the control is set low enough to allow the unit to run for the entire length of the brazing, evacuation, and charging procedure.
- Remove the valve depressors from the gauge hoses on a four-valve manifold.
- Connect the manifold to the low-pressure service valve port on the condensing unit and a nitrogen tank.
- Open the suction line service valve and purge the system with nitrogen.
- Braze all connections and cool off quickly.
- Connect the high-pressure hose from the manifold to the liquid line service valve port.
- Pressure test the system at 150 psi for 20 minutes.
- Check all braze joints with leak detector or soap bubbles.
- Release the nitrogen once it is confirmed that there are no leaks.

Evacuation

- Remove the nitrogen tank from the manifold and attach the manifold to the refrigerant tank.
- Mid-seat both service valves.
- Install service caps on the valves.
- Energize the liquid line solenoid valve.
- After confirming that there is fresh oil in the vacuum pump, connect the $\frac{3}{8}$ " hose from the manifold to the pump.
- Start the pump and run it until the micron gauge on the evaporator unit reads 500 microns or less.
- Disconnect the vacuum pump from the system.
- Break the vacuum by pressurizing the system to approximately 5 PSI with R-134a refrigerant.
- Remove the micron gauge from the access valve.

INSTALLING THE CONDENSING UNIT (continued)

Charging

- With the power off to the condensing unit, admit liquid refrigerant through the liquid line service valve until the refrigerant stops flowing.
- Turn on the circuit breaker for the condensing unit. The compressor should turn on if the pressure in the suction line is above 25 psi.
- Add refrigerant (in vapor form) to the low side of the system through the suction line service port.
- Observe the sight glass. If bubbles are present, add more refrigerant (in vapor form) to the low side.
- Once the sight glass is clear, check the superheat at the outlet of the evaporator unit. Adjust the TXV until the superheat is between 20-30°F at the service valve.
- Under normal operation, with the wine cellar at 55°F and the ambient temperature at 85°F, the low side pressure should be between 28-32 PSI and the high side should be between 145-155 PSI.

Finalizing the Installation

- Confirm that the entire suction line from the TXV to the suction line service valve is insulated using cellular insulation or equivalent. Seal all seams with Armaflex 520 Foam Insulation Adhesive or equivalent.
- Confirm that the control is displaying the correct temperature and that no alarms are present. Refer to page 38 for corrective action if alarms are present.

Charging Information

- A. Energize the solenoid valve on the evaporator unit by plugging the unit in and adjusting the thermostat to call for cooling.

WM2500 WIRING PROCEDURES

1. Locate or install an electrical outlet near the condensing unit.
2. Follow the instructions listed below to wire the condensing unit.
3. Leave the circuit breaker off until the unit is ready to charge.

NOTE: Do not apply power to a system without refrigerant.

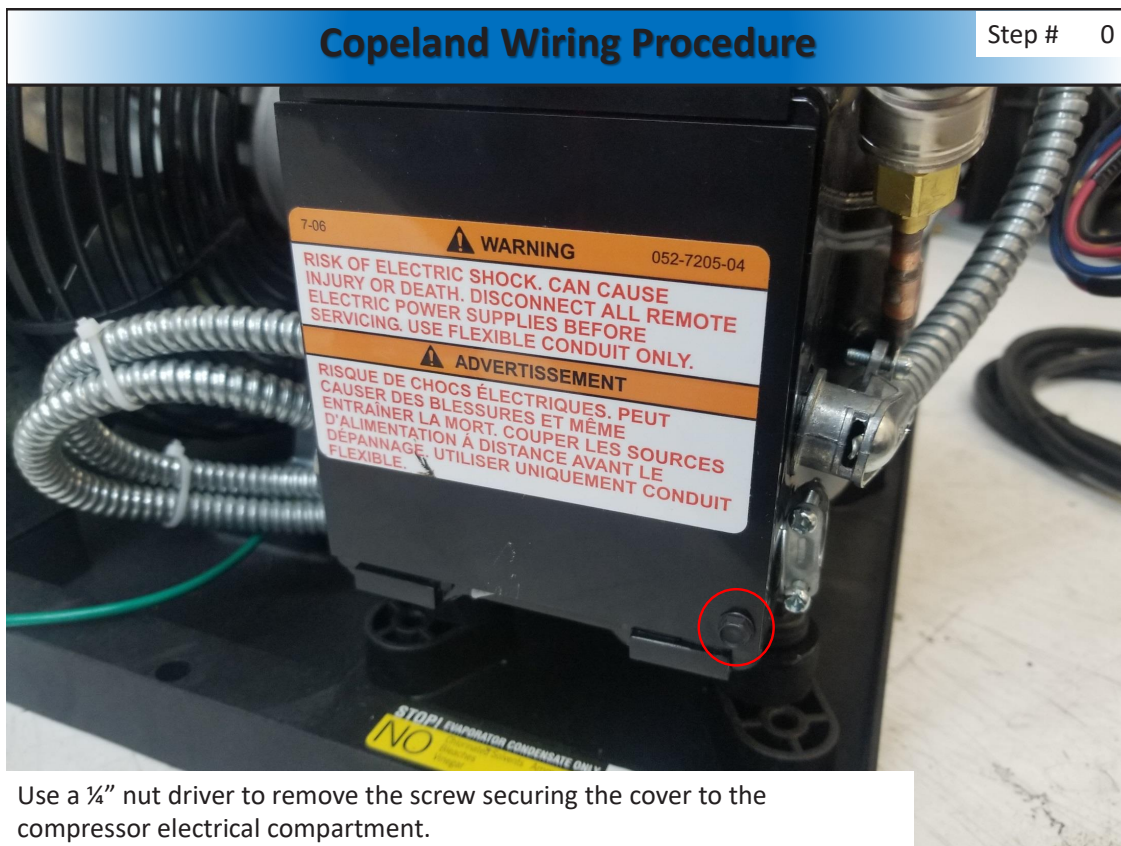

Copeland Wiring Procedure

Step # 1

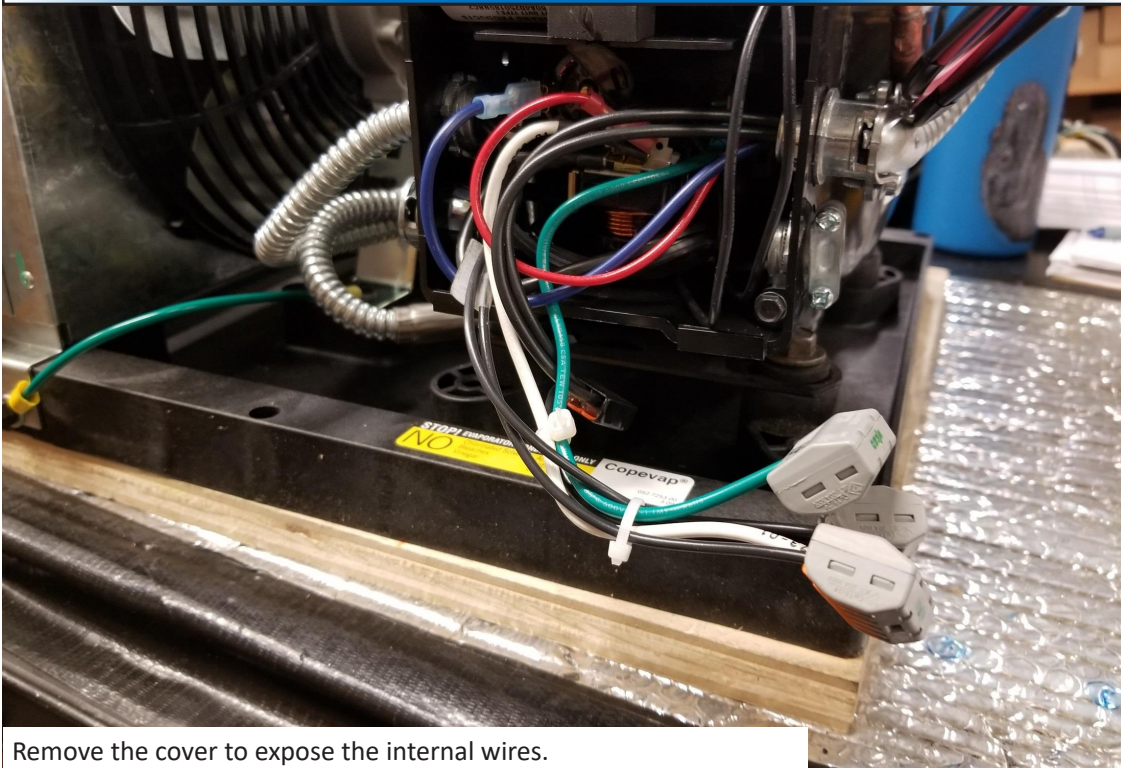

Remove the cover to expose the internal wires.

Copeland Wiring Procedure

Step # 2

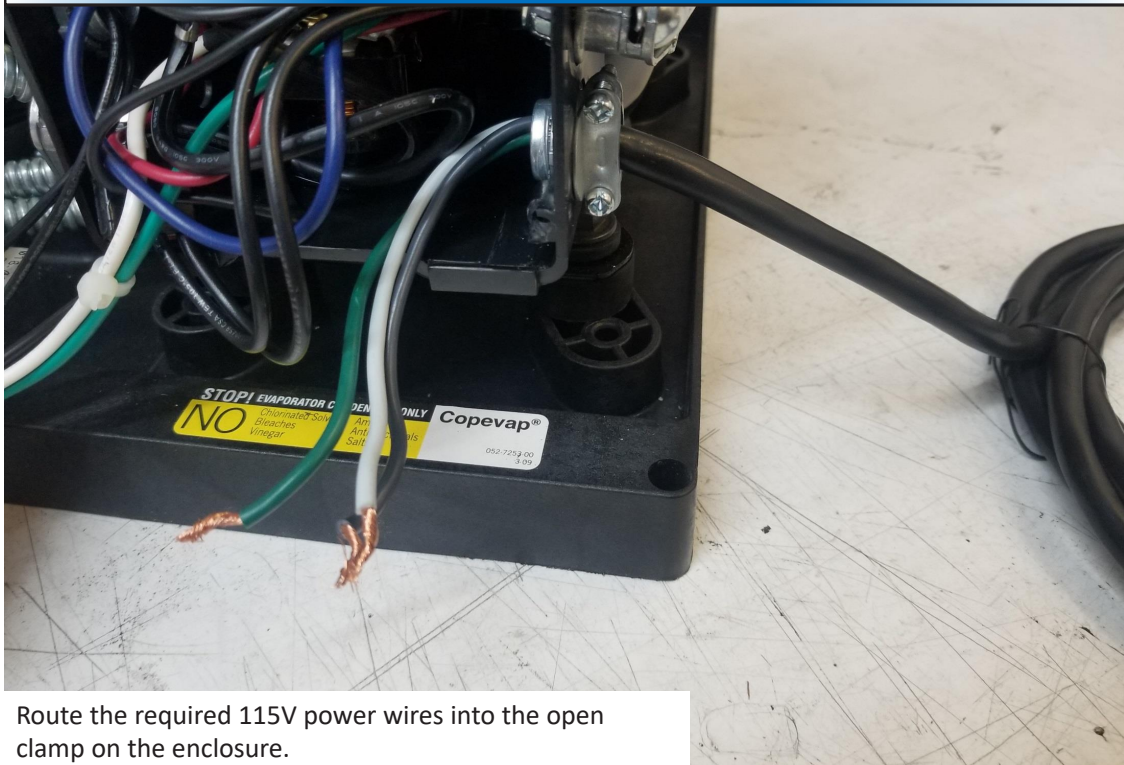

Route the required 115V power wires into the open clamp on the enclosure.

Copeland Wiring Procedure

Step # 3



Tighten the screws on the clamp to secure wire casing or conduit in place.

Copeland Wiring Procedure

Step # 4

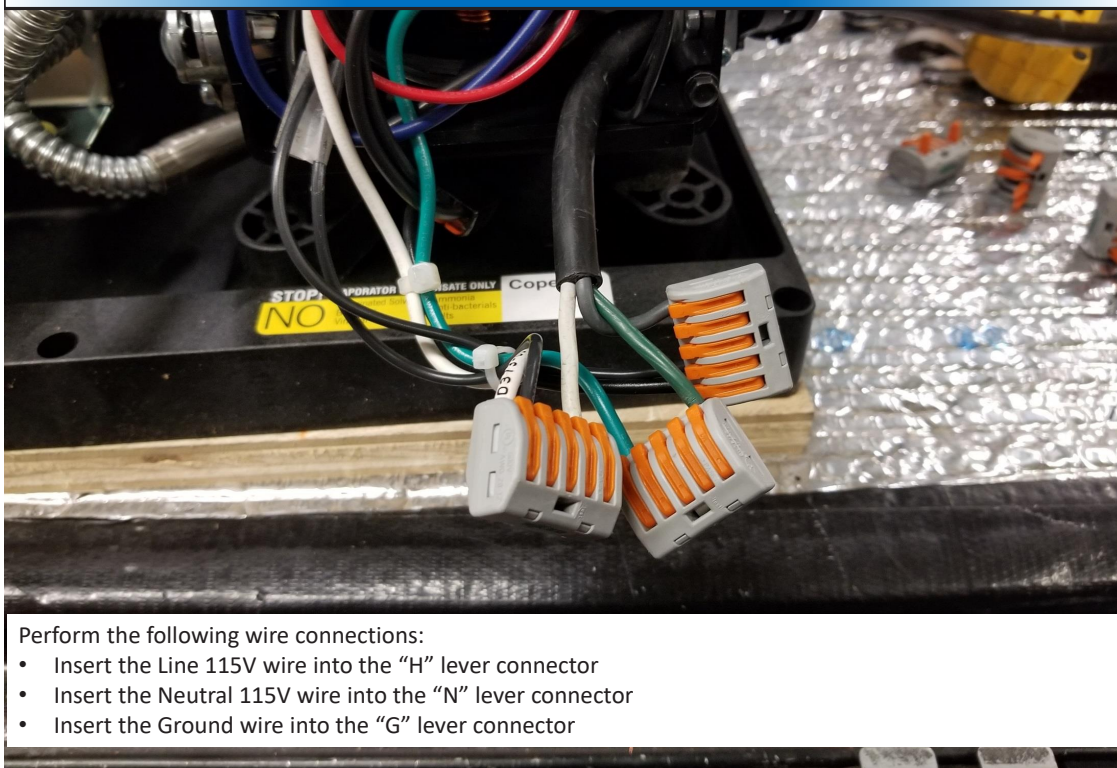

Perform the following wire connections:

- Insert the Line 115V wire into the "H" lever connector
- Insert the Neutral 115V wire into the "N" lever connector
- Insert the Ground wire into the "G" lever connector

Copeland Wiring Procedure Step # 5



Push wires back into enclosure.

Copeland Wiring Procedure Step # 6



Re-install cover.

SYSTEM OPERATION

Initial Start-Up

When the unit is plugged in and power is sent to the controller, a beep will sound, confirming that the controller is getting power. All LEDs on the display will blink three times. Three dashes will then appear on the screen. All display LEDs will then blink three times. Once the controller has gone through the initial startup process, and all LEDs have cycled, the home screen will be displayed.

Setpoint

The setpoint is preset at the factory to 55°F. It can be adjusted by the customer between 50–70°F in one-degree increments.

Indoor Fan Operation

The indoor fan will run when the controller is calling for cooling and turn off once the cooling cycle has ended. During the cooling cycle, the system will remove some relative humidity from the cellar. Some of the humidity that was removed can be reintroduced into the cellar by adjusting the “fan on” and “fan off” functions. (The cooling system is not equipped with a humidifier and does not add humidity.)

The FOF cycle should be shortened first. This will reduce the amount of time that the fan remains off following a cooling cycle. When the unit has completed a cooling cycle, the compressor and the condenser fan will turn off, but the indoor fan will continue to run for whatever length of time the customer has set. The Fon function may then be lengthened to allow the fan to run longer and reintroduce moisture from the evaporator coil back into the wine cellar.

For more information about fan settings, refer to the User Menu on page 39.

Anti-Short Cycle

The Anti-Short Cycle ensures that the unit will remain off for a period of five minutes after the unit has reached the setpoint. This allows the pressure in the refrigeration system to equalize prior to starting the compressor.

Once the solenoid relay is de-energized, the controller must wait five minutes before reenergizing the relay. This prevents the compressor from repeatedly turning off and on. If the unit is calling for cooling during this time, the compressor icon will blink, indicating that cooling is needed but the controller is waiting for the Anti-Short Cycle delay.

Anti-Frost Cycle

When the evaporator probe senses a temperature of 26°F for a duration of one minute, an Anti-Frost Cycle will be initiated. This will shut down the compressor, allowing the evaporator fan to run and melt any frost accumulation on the coil. While the Anti-Frost Cycle is running, “dEF” will be displayed on the screen.

The compressor will remain off until the evaporator coil reaches 40°F, or for a maximum of one hour. The unit will then return to normal operation.

Operation in Low Ambient Temperatures

The condensing unit comes equipped with a LAC (Low Ambient Control). The LAC is a three-way modulating valve that responds to discharge pressure. When the discharge pressure falls below the valve’s dome pressure, the valve modulates open to the discharge port which allows discharge gas to bypass the condenser. Mixing the discharge gas with the liquid creates high pressure at the condenser outlet, reducing the flow and causing liquid to backup in the condenser. Flooding the condenser reduces the area available for condensing. This reduction in condenser surface area results in a rise in condensing pressure during cold ambient conditions.

The condensing unit controller is preset at the factory. The cut-in pressure is preset to 25psi and the cut-out pressure at 15psi. During low ambient temperatures (40°F or below), it will be necessary to adjust the cut-in pressure to 10-15psi (15psi is preferred) and the cut-out to 5psi to ensure compressor startup. See page 40 for instructions on adjusting the cut-in and cut-out pressures of the condensing unit.

Digital Display

The display is designed to give the user the ability to adjust the setpoint, Fon/FOF parameters, and other settings. (See User Menu on page 39 for more details.) The bottle probe temperature is displayed by default. “dEF” will be displayed during an Anti-Frost Cycle. The bottle probe and evaporator probe temperatures can be accessed by pushing the SET button and scrolling through “Pb1” (bottle probe) and “Pb2” (evaporator probe). The light button may be used as an unlock button.



Safety Features

In the event of a faulty bottle probe, the compressor will cycle off for 10 minutes and on for 40 minutes. “E1” will be displayed on the screen.

Alarms

See “Alarm Codes” in the Controller Functions chart.

DISPLAY LAYOUT

 Compressor is on  Alarm is present

 Fan is on

 Anti-Frost Cycle running

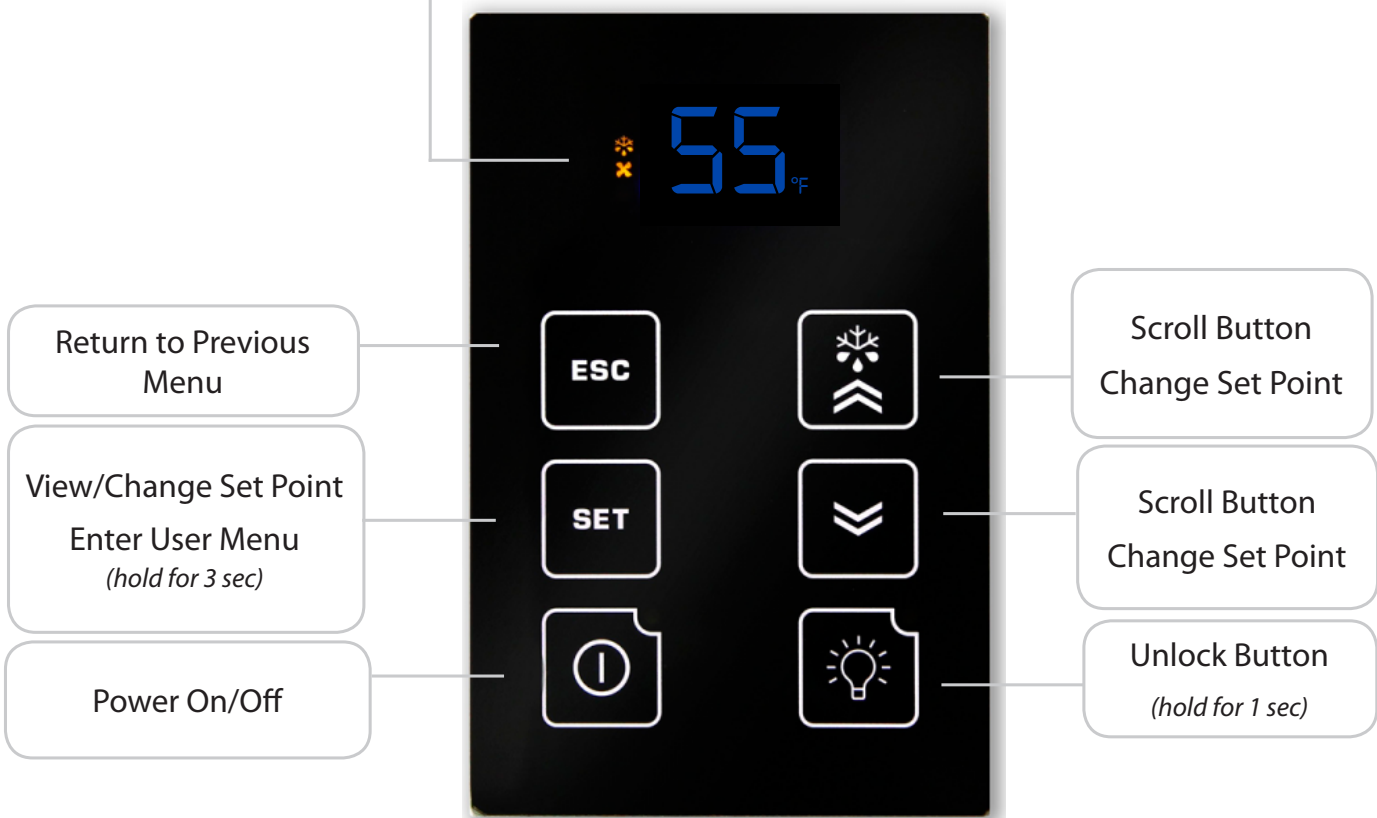

Return to Previous Menu

View/Change Set Point
Enter User Menu
(hold for 3 sec)





Power On/Off

Scroll Button
Change Set Point





Scroll Button
Change Set Point

Unlock Button
(hold for 1 sec)



CONTROLLER FUNCTIONS

Button	Normal Functions								
INITIAL STARTUP	When the unit is plugged in and power is sent to the controller, a beep will sound, confirming that the controller is getting power. All LEDs on the display will blink three times. Three dashes will then appear on the screen. All display LEDs will then blink three times. Once the controller has gone through the initial startup process, and all LEDs have cycled, the home screen will be displayed.								
UNLOCKING THE DISPLAY	Press and hold any button for one second to unlock the display. (A white LED will appear in the top left corner of the button being pressed.) A beep will sound, signifying that the display is unlocked. NOTE: The display must be unlocked before any button functions become available.								
ON/OFF 	To turn the unit ON, press and hold the ON/OFF button until the red LED turns OFF. To turn the unit OFF, press and hold the ON/OFF button until the red LED turns ON.								
UP/DOWN 	The up and down arrows are used to navigate through menus and adjust parameters such as set point, Fon/FOF, etc.								
SET 	<ul style="list-style-type: none"> To change the set point, press the SET button. When "SEt" is displayed on the screen, press the SET button once more. Use the UP and DOWN ARROW buttons in order to change the value until the desired set point is reached. The SET button allows you to view the set point, evaporator temperature, bottle temperature, alarms, and the hidden menu. Press the SET button once. "SEt" will be displayed. Press the UP or DOWN ARROW buttons to scroll through ALr, Pb1, or Pb2. <table border="1" data-bbox="470 1186 1518 1354"> <thead> <tr> <th>Set</th> <th>Set point</th> </tr> </thead> <tbody> <tr> <td>ALr</td> <td>Alarm folder</td> </tr> <tr> <td>Pb1</td> <td>Liquid (bottle probe) temperature</td> </tr> <tr> <td>Pb2</td> <td>Evaporator coil temperature</td> </tr> </tbody> </table> <ul style="list-style-type: none"> Press the SET button again to view any of these values. Hold the SET button for approximately 5 seconds to enter the User Menu. (More information about the User Menu is available on page 39.) Other parameters in the User Menu which are not available for adjustment include: idF, rEL, and LAN. 	Set	Set point	ALr	Alarm folder	Pb1	Liquid (bottle probe) temperature	Pb2	Evaporator coil temperature
Set	Set point								
ALr	Alarm folder								
Pb1	Liquid (bottle probe) temperature								
Pb2	Evaporator coil temperature								
ESC 	This button confirms changes made to parameters such as the set point and returns you to the previous menu.								
LIGHT 	The light function is not in use. However, this button can still be used to unlock the display.								

ICON GLOSSARY

Icon	Meaning
<p>SNOWFLAKE</p> 	<p>Blinking: The unit is calling for cooling, but must wait five minutes before restarting the compressor. This five-minute delay serves as an Anti-Short Cycle for the compressor's protection.</p> <p>Constant: The unit is in cooling mode and the condensing unit is running.</p>
<p>DRIPPING SNOWFLAKE</p> 	<p>The unit is undergoing an Anti-Frost Cycle. While the Anti-Frost Cycle is running, "dEF" will be displayed on the screen. See System Operation page for further details.</p>
<p>FAN</p> 	<p>The evaporator fan is running.</p>
<p>ALARM</p> 	<p>The alarm icon is shown when the unit encounters an issue that needs attention. Alarm codes are explained on the following page. All temperature-related alarms are blocked for the first 10 hours after the unit is plugged in to allow the system to stabilize and acclimate to the new environment.</p>

ALARM CODES

Code	Cause	Solution
The following alarm codes will be displayed on the screen along with the alarm icon. 		
E1	Bottle probe is not connected	Attach bottle probe to circular connector (see instructions on page 10)
	Faulty bottle probe connection	Locate faulty bottle probe connection by inspecting all wiring connections between the bottle probe and the circuit board. The two-pin connector for the bottle probe should be connected to the CPB/PB1 terminal on the circuit board. If it is not connected, plug it in. If a faulty connection has been identified, correct the issue or contact customer service for further assistance. NOTE: The E1 code will not appear in the alarms menu. It will be permanently displayed on the screen.
	Defective bottle probe	Replace the bottle probe
E2	Faulty evaporator probe connection	Locate faulty evaporator probe connection by inspecting evaporator probe wire. The two-pin connector for the evaporator probe should be connected to the CPB/PB2 terminal on the circuit board. If it is not connected, plug it in.
	Defective evaporator probe	Replace the evaporator probe
E7	No communication between keypad and circuit board for 60 seconds	Verify that the display cable is connected to the keypad and the circuit board and is not damaged, frayed, or kinked. If problem persists, contact Customer Service for troubleshooting information.
E10	Clock battery is dead	Replace battery NOTE: A dead clock battery will not affect the operation of your cooling unit.
The following alarm codes will not be displayed on the home screen. However, the alarm icon will be displayed in the event of an alarm. The alarms can be viewed in the Set Menu's ALr folder. 		
EA	Unit is not draining properly	<ol style="list-style-type: none"> 1. Check to see that the unit is level; if not, level it 2. Verify that the drain line is not clogged; if so, clear obstruction 3. Ensure that the condensate pump is operating 4. Verify wire connection at D.I. port of circuit board NOTE: If the drain line is obstructed or the pump fails for some reason, and the water level in the drip tray gets too high, the unit will not operate until the water in the internal drip tray drops back below the proper level.
AH1	The bottle probe is sensing a temperature that is 8°F above the set point	<ol style="list-style-type: none"> 1. Allow time for the wine to reach the desired temperature 2. Ensure that the cellar is sealed properly 3. Verify that the bottle probe is calibrated correctly (refer to the User Menu on the following page) 4. Verify that the unit is sized correctly for the cellar
AL1	The bottle probe is sensing a temperature that is 8°F below the set point	<ol style="list-style-type: none"> 1. Make sure the unit is not in cooling mode (the snowflake icon will not be illuminated) 2. Add heat to the room until the wine reaches the desired temp 3. Verify that the bottle probe is calibrated correctly (refer to the User Menu on the following page)
Ad2	The Anti-Frost Cycle ended on time-out	<ol style="list-style-type: none"> 1. Check the evaporator coil for ice buildup. Unplug the unit and allow the coil to thaw before restarting. 2. Make sure the room to which the unit is exhausting is not below 60°F 3. If the unit repeatedly goes into Anti-Frost Cycles (one per minute), call Customer Service for more troubleshooting information

USER MENU

The User Menu is accessed by **pressing and holding the SET button for 3 seconds**. Use the UP and DOWN ARROW buttons to navigate to desired parameters. Press the SET button again to view these parameters. Press the UP and DOWN ARROW buttons to adjust a parameter.

The following parameters are available in the menu:

Parameter	Description
Fdc - humidity enhancement	This parameter is measured in minutes, and is preset at the factory to 1. An increase in this parameter will increase the humidity enhancement of your cellar. This parameter should not be adjusted to zero. Adjustments should be made in increments of 5, with a maximum of 15 and a minimum of 1. After making any adjustments to humidity enhancement, you should wait a minimum of 3 days before making any additional adjustments. This will allow sufficient time for the cellar to acclimate to the new setting.
FOF - "fan off"	This setting controls how long the fan stays off after the set point has been reached. It is preset to 15 minutes. This setting should not be adjusted, as most properly constructed wine cellars retain an ample amount of humidity during the "fan off" cycle. If, however, you wish to decrease the duration of the "fan off" cycle (in order to increase the wine cellar's relative humidity), you can adjust this setting in the User Menu.
Fon - "fan on"	The "fan on" time is preset to zero minutes. This keeps the relative humidity of the wine cellar at a stable level. If, however, you wish to raise the relative humidity of your wine cellar, you can increase the duration of the "fan on" cycle in increments of five (5, 10, or 15 minutes). After making any adjustment to the "fan on" cycle, you should wait a minimum of 3 days before making any additional adjustments. This will allow sufficient time for the cellar to acclimate to the new setting.
CA1 - bottle probe (Pb1) calibration	CA1 - bottle probe (Pb1) calibration: You may use this parameter to calibrate the bottle probe to a known temperature. This parameter can be adjusted between -12°F and 12°F. For example, if the bottle probe temperature is 58°F, and the known temperature is 55°F, you can set the CA1 parameter to -3°F to match the known temperature.
PA2 - installer menu	This menu is only accessible using a password and is not available for adjustment.
dOA - digital input	This setting determines which of the unit's components will be activated or deactivated when a certain electrical relay is activated or deactivated in response to an alarm. The controller comes pre-programmed with a factory setting of 2. 2 = activates the compressor and fans 5 = disables the compressor and fans NOTE: Setting the dOA to any number other than 2 or 5 will prevent the unit from operating properly.

Emerson™ Electronic Unit Controller

Quick setup and troubleshooting guide

Adjusting Low Pressure Settings

- Hold DOWN and SET simultaneously for 3 seconds to enter menu (PSI light will flash) ▼ + SET
- Cycle through menu options – UP/DOWN ▲ ▼
- Select function – SET SET
- Adjust value – UP/DOWN ▲ ▼
- Store function - SET SET
- Exit menu - UP and SET ▲ + SET



Low Pressure Cut-In



Low Pressure Cut-Out

Accessing Alarm Code Information

- Press and release ALARM 📖
- Cycle through menu options – UP/DOWN ▲ ▼
- Press SET to see number of alarms SET
- Press SET again to return to menu options SET
- Exit menu - UP and SET ▲ + SET

Alarm	Description
PoF	Keypad locked
Pon	Keypad unlocked
P1	Suction probe failure
P2	Condenser probe failure
P3	DLT probe failure
HA	High condenser temperature alarm
dLt	DLT temperature alarm
dLL	DLT lock alarm
HP	High pressure trip alarm
HPL	High pressure trip lock-out alarm
EE	Module Failure
LOC	Number of lock-outs

Note: After 15 seconds of inactivity the controller will revert to the default display.

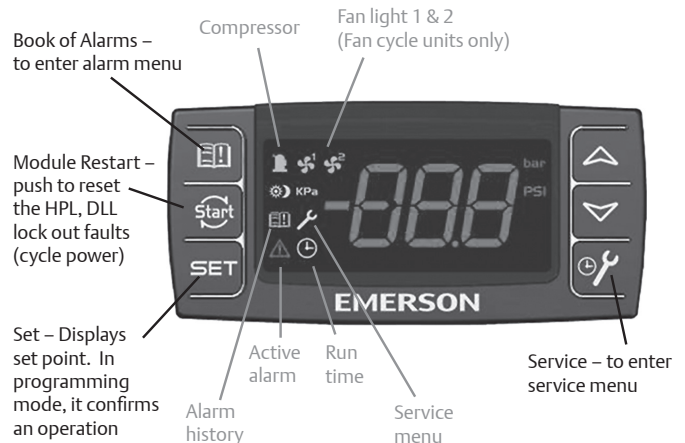

When light is on, feature or component is on or active

Accessing Service Menu

- Hold SERVICE for 3 seconds 🔧
- Cycle through menu options – UP/DOWN ▲ ▼
- Press SET to see number of alarms SET
- Press SET again to return to menu options SET
- Exit menu - UP and SET ▲ + SET

Code	Description
StH	CompressorStarts -1000 -999999
StL	Compressor Starts -0 -999
CHH	CompressorHours -1000 -999999
CHL	Compressor Hours -0 -999
F1H	Fan 1 Hours -1000 -999999
F1L	Fan 1 Hours-0 -999
F2H	Fan 2 Hours -1000 -999999
F2L	Fan 2 Hours -0 -999

Example: If StH=12 and StL=500, the total number of compressor starts=12,500

For more information visit EmersonClimate.com/ElectronicUnitController or call 1-888-367-9950



Display	Likely Causes	Other Possible Causes
Controller display remains blank after applying power	<ul style="list-style-type: none"> Unit power not properly applied - check for proper applied voltage Power cable harness not plugged in properly or securely into the back of the controller – check connections 	<ul style="list-style-type: none"> Power cable miswired – inspect cable, replace if needed Electrical assembly miswired – trace wiring diagrams
Controller displays correctly, but the green compressor light is off and the compressor is not running	<ul style="list-style-type: none"> Jumper cable not plugged in properly or securely into the back of the controller – check connections Controller is currently above the cut-in setting – check cut-in and cut-out settings 	<ul style="list-style-type: none"> Jumper cable miswired – inspect cable, replace if needed
Controller displays correctly and the green compressor light is on and the compressor is not running	<ul style="list-style-type: none"> Power cable harness not plugged in properly or securely into the back of the controller – check connections 	<ul style="list-style-type: none"> Power cable not wired to the contactor or compressor correctly, check wiring Power cable miswired – inspect cable, replace if needed
Controller flashes “135” or “P1”	<ul style="list-style-type: none"> Current system pressure is above 135 PSIG – wait for system to pull down Green harness not plugged in properly or securely into the back of the controller – check connections Cable not connected properly with the pressure transducer – check connections 	<ul style="list-style-type: none"> Transducer cable miswired – inspect cable, replace if needed Damaged transducer – inspect transducer, replace if needed
Controller flashes “P2” on a unit with fan cycling	<ul style="list-style-type: none"> Green harness not plugged in properly or securely into the back of the controller – check connections 	<ul style="list-style-type: none"> Transducer cable miswired – inspect cable, replace if needed Check condenser temperature sensor resistance values against table in AE-1376, Section 8
Controller flashes “P2” on a unit without fan cycling after replacing a controller	<ul style="list-style-type: none"> Controller not programmed properly – check parameters in the advanced menu 	
Controller flashes “P3” on a unit with DLT	<ul style="list-style-type: none"> Jumper cable not plugged in properly or securely into the back of the controller – check connections 	<ul style="list-style-type: none"> Jumper cable miswired – inspect cable, replace if needed Faulty DLT temperature sensor – check the discharge line temperature sensor resistance values against table in AE-1376, Section 8
Controller flashes “P3” on a unit without DLT after replacing a controller	<ul style="list-style-type: none"> Controller not programmed properly – check parameters in the advanced menu 	
Fans not running on a fan cycling unit and the fan lights are not on	<ul style="list-style-type: none"> Condensing temperature is currently below the fan cut-in Condensing temperature sensor not properly installed – check installation 	<ul style="list-style-type: none"> Transducer cable miswired – inspect cable, replace if needed Faulty temperature sensor - check condenser temperature sensor resistance values against table in AE-1376, Section 8
Fans not running on a fan cycling unit and the fan lights are on	<ul style="list-style-type: none"> Power cable harness not plugged in properly or securely into the back of the controller – check connections 	<ul style="list-style-type: none"> Power cable miswired – inspect cable, replace if needed Electrical assembly miswired – trace wiring diagrams
Controller flashes “HP” at power-up	<ul style="list-style-type: none"> Jumper cable not plugged in properly or securely into the back of the controller – check connections High pressure switch is seeing above the cut-out pressure For a replacing an -00 controller, ensure that the jumper cable is the latest revision. It should have a blue wire in the harness. See replacement instructions for more details 	<ul style="list-style-type: none"> Jumper cable miswired – inspect cable, replace if needed Faulty fixed Hp switch – inspect switch, replace if needed
Controller flashes “HP” or “HPL”	<ul style="list-style-type: none"> System operation causing high discharge pressures, check system operations 	<ul style="list-style-type: none"> Bad high pressure switch, verify system pressure when the pressure switch trips. See AE-1376, Section 7.2 for more details
Controller flashes “DLT” or “DLL”	<ul style="list-style-type: none"> System operation causing high discharge line temperatures, check system operations 	<ul style="list-style-type: none"> Faulty temperature sensor - check DLT sensor values against table in section 8 See AE-1376, Section 7.1 for more details
Controller flashing “HPL” or “DLL”	<ul style="list-style-type: none"> System operation causing high discharge pressures (HPL) or high discharge line temperatures (DLL) repeatedly, check system operations To clear an “HPL” or “DLL” lockout, you can hold the Restart button for 3 seconds twice, or cycle power to the unit. If using the reset button, the alarm condition will have to clear (DLT temperature drops or Hp switch resets), and any minimum off time will need to complete (5 minutes for the fixed Hp switch) 	

EmersonClimate.com/ElectronicUnitController

2013ECT-46 (9/13) Emerson is a trademark of Emerson Electric Co. ©2013 Emerson Climate Technologies, Inc. All rights reserved.

EMERSON. CONSIDER IT SOLVED.™

CELLARCOOL TROUBLESHOOTING GUIDE

Unit has ice forming on the evaporator unit	
Possible cause	Solution
Evaporator filter or coil is dirty	Remove the filter and wash it, then clean the coil with a vacuum. If coil is very dirty, use a spray bottle with a small amount of liquid dish detergent or coil cleaner. Spray coil, let set for five minutes, then flush with fresh water.
There is something blocking the supply and/or return air	Remove blockage
The evaporator fan is not turning on	Call a service tech to troubleshoot
The evaporator unit has not gone through its Anti-Frost sequence yet	Check the coil for surface ice. Melt with blow drier until coil is warm to the touch. Soak up water with a towel.
If evaporator unit continues to ice	Observe ice formation pattern. If only part way up the coil face, the system could be low on refrigerant. If all the way up, the coil may be dirty or airflow is blocked.
Unit does not run/power up	
Possible cause	Solution
Evaporator unit is not plugged in	Make sure the unit is plugged into an outlet
Power switch not on	Turn unit on by pressing the power button on the control
Line voltage rating is incorrect for the system	Check line voltage to make sure it is 110V-120V
Bottle at set point	Lower set point
Thermostat not calling for cooling	Lower set point
Faulty thermostat or wiring	Call Customer Service at 1-800-343-9463
Cellar temperature is too warm	
Possible cause	Solution
The temperature of the room to which the condensing unit exhausts exceeds 110°F	Intake temperature must drop below 110°F
The system is undersized for the cellar	Order correct size system
There is something blocking the supply and/or return air on the evaporator unit or the condensing unit	Remove air flow obstruction
Evaporator unit is mounted too low in the cellar	Relocate unit so the distance from the ceiling and top of the unit is no more than 18"
One or more of the fans is not turning on	Please contact the installing technician to troubleshoot
Compressor is not turning on	Please contact the installing technician to troubleshoot
Compressor keeps cycling on overload	Make sure all fans are working and there is no airflow obstruction
Poor seal around door or other areas requiring a seal (around the unit, wall joints, etc.)	Make sure there are no air gaps around the door. If door seal is damaged, replace it.
Controller set too high	Lower the set point
Evaporator coil is frosted or iced up	Observe ice formation pattern. If only part way up the coil face, evaporator unit could be low on refrigerant. If so, contact your installing technician to assist with troubleshooting.
System runs constantly	
Possible cause	Solution
Leaky door seal or poorly insulated cellar	Fix leaky door seal and insulate cellar

Unit leaks water	
Possible cause	Solution
Evaporator unit is not level	Evaporator unit should be level on the wall to prevent leaking
Drain line clogged or kinked	Check drain line to make sure water can flow freely
Drain is clogged, preventing water from escaping	Disconnect drain and clear it out; open access door and check drain for blockage
Drain line does not have a downward slope	Fix drain line so there is a downward slope from the unit to the drain
Coil is iced, causing drain pan to freeze and water to overflow	Melt ice with blow drier. Soak up with a towel.
Unit runs but does not cool	
Possible cause	Solution
Lack of air flow	Make sure fan is unobstructed and that the evaporator filter, evaporator coil, and condenser coil are clean and free of debris
System undersized	Contact Customer Service at 1-800-343-9463
Compressor is overheating	Shut system off for 1 hour to allow compressor to cool. Turn back on and check for cooler airflow out. If compressor runs, check for and clean condenser coil as possible cause of compressor overheating. If problem repeats, contact you installing technician to assist with troubleshooting.
Evaporator fan runs but compressor does not	
Possible cause	Solution
Running an Anti-Frost cycle	1) If the system is maintaining the correct cellar temperature and there is a dripping snowflake symbol illuminated on the display, the system is going through an Anti-Frost Cycle. No action is required. 2) If the system is not maintaining the correct cellar temperature, this may be due to a dirty evaporator filter or coil. 3) Call the installing technician to troubleshoot, as the system may be low on charge or require an adjustment to the TXV.
Compressor and/or starting components faulty	Please contact the installing technician to troubleshoot
System may be performing the WHM function	Allow cooling system to revert back to cooling mode
Compressor may have overheated	Shut system off for 1 hour to allow compressor to cool. Turn back on and check for cooler airflow out. If compressor runs, check for and clean condenser coil as possible cause of compressor overheating. If problem repeats, contact your installing technician to assist with troubleshooting.
Compressor runs but evaporator fan does not	
Possible cause	Solution
Faulty fan motor	Please contact the installing technician to troubleshoot
Faulty controller	Please contact the installing technician to troubleshoot
Compressor short cycles	
Possible cause	Solution
Evaporator unit blows on bottle probe	Move bottle probe to a more central location
System low on refrigerant charge	Please contact the installing technician to troubleshoot
Condensing fan motor/capacitor faulty	Please contact the installing technician to troubleshoot
Compressor and /or starting components faulty	Please contact the installing technician to troubleshoot
Humidity in cellar too low	
Possible cause	Solution
Not enough moisture	Raise the "fan on" setting to increase the humidity level

MAINTENANCE SCHEDULE

Monthly	<ol style="list-style-type: none"> 1. Check for debris surrounding condensing unit (leaves, branches, trash, etc); remove all obstructions 2. Check for unusual noise or vibration 3. Check the drain line to see if it is above the waterline (if draining into a vessel)
Quarterly	<ol style="list-style-type: none"> 1. Use a vacuum with brush attachment to clean the evaporator coil; be careful not to crush coil fins when cleaning 2. Remove the evaporator filter and clean with warm water 3. Ensure the condensing unit is free of debris and dust 4. Have a certified HVAC-R technician service the condensing unit and clean the condenser coil
Annually	<ol style="list-style-type: none"> 1. Inspect for corrosion 2. Check wiring connections and integrity of cords 3. Pour a 50/50 bleach solution into the drain line every spring

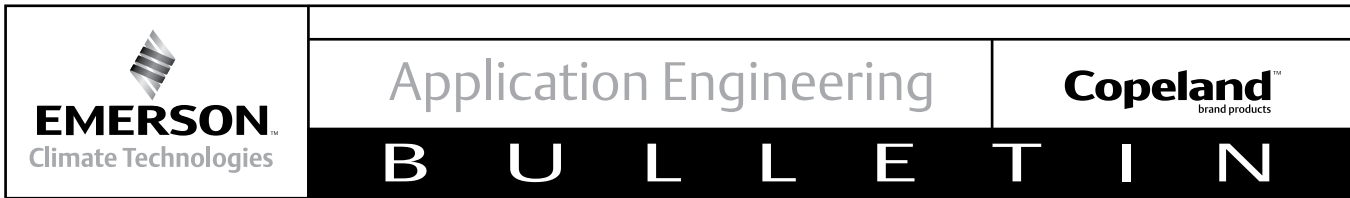

AE5-1340

October 2006

Care and Cleaning of Air Cooled Condensing Units

Introduction

Proper care is essential to assure good life of condensing units. Dirty or damaged condensers will reduce the efficiency and capacity of the system.

Care must be taken in choosing solutions to be used for cleaning condensers and condensate pans. Chlorinated cleaners and anti-bacterial cleaning agents can be damaging and should be avoided. Caustic and acidic cleaners should be avoided as well. Failure to do so may accelerate component corrosion and ultimately lead to component failure.

Condenser Coils

There are many commercially available condenser coil cleaners on the market. Coil cleaners should be designed to remove build-up on fins and coils. Coils should be thoroughly rinsed of the cleaners once cleaning has been completed. Follow the manufactures instruction for proper usage. Preventive maintenance and routine cleaning of coils is important to assure good life.

When cleaning the coil, an absorbent type material should be placed under the area to be cleaned in order to capture most of the cleaning compound, thus minimizing any type of chemical attack.

Condensate Pans

Condensing units with condensate pans and condensate tubes are designed to evaporate condensate water only. Other ingredients introduced into the condensate pan can accelerate pan and/or tube corrosion. As foreign agents are introduced into the condensate pan, condensate water will be evaporated leaving the foreign agent behind. This can lead to a high concentration of the agent and possible corrosion of the tubing and/or base.

Coil cleaning agents must not be allowed to drain into the condensate pan as this may cause damage. Upon completing the coil cleaning, be certain that all residue is removed from the condensate pan.

Only non corrosive cleaners should be used to assure good life of the condensing unit components. No hydrocarbon based cleaners should be used to clean the unit. Bleach solutions must be avoided due to its high corrosive nature.

Under no circumstances should cleaning agent ingredients contain any of the solutions listed below:

Unacceptable solutions are:

- Chlorinated Solvents**
- Bleaches**
- Vinegar**
- Ammonia**
- Anti-Bacterials**
- Salts**

Preventative Maintenance

Maintenance should be performed at regular intervals. Coils should be cleaned at least monthly, possibly more depending on the environment. Condensing units with condensate pans should also be checked and cleaned regularly to prevent damaging build up in the pan.

Safety

Please follow all safety recommendations listed by the manufacturer of the cleaning agent(s), these would include proper clothing, gloves and eye protection.

TECHNICAL ASSISTANCE

CellarCool Customer Service is available Monday through Friday from 6:00 a.m. to 4:00 p.m. Pacific Standard Time.

The appointed customer service representative will be able to assist you with your questions and warranty information more effectively if you provide them with the following:

- The model and serial number of your CellarCool systems.
- Location of unit and installation details, such as ventilation, ducting, construction of your wine cellar, and room size.
- Photos of the cellar and installation location may be needed.

Contact CellarCool Customer Service

1738 E. Alpine Ave
Stockton, CA, 95205
www.cellarcool.com

Email: support@cellarcool.com

Tech Support & Customer Service: 1-800-343-9463

Sales & Sizing Assistance: 1-855-235-5271

Fax: 209-466-4606

Visit www.emersonclimate.com/electronicunitcontroller for online brochures, bulletins, instruction videos, and general product information.

Download the Copeland Mobile App on your mobile device for additional troubleshooting and technical information.



ACCESSORIES FOR COOLING UNITS

CellarCool offers accessories to enhance and customize your wine cooling unit:

Exterior Housing

Protects the condensing unit from the weather elements when the unit is located outside.

Condensate Pump Kit

The condensate pump kit is designed as an automatic condensate removal pump for water dripping out of our evaporator unit's (Fan Coil Unit's) drain line. The pump is controlled by a float/switch mechanism that turns the pump on when approximately 2¼" of water collects in the tank, and automatically switches off when the tank drains to approximately 1¼". The condensate pump kit allows the excess condensate to be pumped up to 20 ft. away from the unit.

Accessories can be purchased at www.cellarcool.com

**CellarCool Product Terms and Conditions
Including Product Limited Warranty And Product Installation Requirements
For CellarCool Split System Series**

ATTENTION: PLEASE READ THESE TERMS OF USE CAREFULLY BEFORE INSTALLING YOUR CELLARCOOL COOLING SYSTEM. INSTALLING YOUR CELLARCOOL COOLING SYSTEM INDICATES THAT YOU ACCEPT AND AGREE TO EACH OF THE TERMS AND CONDITIONS SET FORTH HEREIN ("TERMS OF USE"). IF YOU DO NOT ACCEPT THESE TERMS OF USE, YOU RISK VOIDING YOUR WARRANTY AND ASSUMING ADDITIONAL REPAIR AND REPLACEMENT COSTS.

1. Purchase of a CellarCool Cooling System assumes that the Purchaser ("End User") fully accepts and agrees to the Terms and Conditions set forth in this document. The Terms and Conditions of Sale and Owner's Manual are shipped with each unit and, if another copy is needed, replacement copies can be downloaded from the company website (cellarcool.com) or by contacting CellarCool directly for a new copy. CellarCool reserves the right, in its sole discretion, to change its Terms and Conditions at any time, for any reason, without notice.

2. CellarCool Product Installation and Limited Warranty

- A. Purchaser of the product must arrange for the product to be installed by a certified HVAC/R technician in accordance with procedures set forth by CellarCool and described in the CellarCool Owner's Manual.
- B. The HVAC/R technician installing the product must complete the designated portion of the Split Startup Checklist and provide licensing or certification identification number information to assist in the warranty registration process.
- C. Purchaser must return the completed Split Startup Checklist to CellarCool within thirty (30) days of installation of Product. The Split Startup Checklist must be approved by CellarCool to activate the Limited Warranty. If the Split Startup Checklist is approved, Purchaser will be sent activation approval documents and will start receiving the benefits of the Limited Warranty throughout the warranty period. If the Split Startup Checklist is incomplete, Purchaser will be informed they have five days to complete the Split Startup Checklist and re-submit to CellarCool. The Split Startup Checklist will be reviewed again, and if denied, Purchaser will be informed that they have 10 business days for corrective action. Failure to register the Product may result in loss of warranty.
- D. Purchaser is responsible for the full costs of installation and any additional parts required for the proper and complete installation of the product.
- E. For Split Systems returned to CellarCool in accordance with the terms and conditions of the Limited Warranty, CellarCool warrants against defects in material and workmanship as follows:
 - 1. LABOR** - For a period of two (2) years commencing on the date of purchase, CellarCool will, at its option and discretion, reimburse up to \$250 to the End User for cost incurred for servicing, repairing, removing or installing warranty parts. Invoice for service must be forwarded to CellarCool for assessment and processing. The Split System warranty is invalid if there is attempted repair by anyone other than an HVAC/R technician approved by CellarCool to service the Product.
 - 2. PARTS** - For a period of two (2) years commencing on the date of purchase, CellarCool will supply, at no charge, new or rebuilt replacement parts in exchange for defective parts. Replacement parts are warranted only for the remainder of the original warranty period.
 - 3. FREIGHT** - For a period of two (2) years commencing on the date of purchase, if after CellarCool approved evaluation the original Product failure is determined to be the cause of a manufacturers defect, and not the cause of an installation error or other cause, CellarCool will cover at its option, freight for the replacement parts or Product.

The following part or cause of failure is not the responsibility of CellarCool:

- Improper voltage supply
- Line set with screw connectors (high end and low end)
- Leaks found at the braze points when performing pressure check
- Unit that has been charged incorrectly
- Incorrect tubing diameter used on line set

- A unit that has been wired incorrectly
- Valve stem on condenser side
- Improper installation of P-Trap
- Lack of P-Trap (if required)
- Condensers that are installed outdoors or in elements that would affect operation without proper cover or housing. (Housing is available from Manufacturer).

Product Warranty Limitations and Exclusions.

1. This limited warranty does not cover cosmetic damage caused during installation, damage due to acts of God, commercial use, accident, misuse, abuse, negligence, or modification to any part of the Product. Delivery and installation of the Product, any additional parts required, as well as removal of the Product if warranty work is required, are all at the sole cost, risk and obligation of the End User.
2. This limited warranty does not cover damage due to improper installation or operation or lack of proper maintenance of the Product, connection of the Product to improper voltage supply, or attempted repair of the Product by anyone other than a technician approved by CellarCool to service the Product.
3. This limited warranty does not cover any Product sold "AS IS" or "WITH ALL FAULTS."
4. Product that has been replaced during warranty period does not extend the warranty period past the original date of purchase.
5. This limited warranty is valid only in the continental United States. Sales elsewhere are excluded from this warranty.
6. Proof of purchase of the Product in the form of a bill of sale, receipted invoice or serial number, which is evidence that the Product is within the Limited Warranty Period, must be presented by the End User to CellarCool in order to obtain limited warranty service.
7. This limited warranty is void if the factory applied serial number has been altered or removed from the Product.
8. This limited warranty is voided if installed in an enclosure of insufficient design that does not follow the Product installation requirements stated herein and in the owner's manual.
9. Removing the rivets from the Product's unit housing without prior authorization from CellarCool voids this limited warranty.
10. The End User must first contact CellarCool Customer Service by telephone (at 1-800-343-9463) prior to attempting service on any Product still under the limited warranty; else the limited warranty is voided.
11. This limited warranty does not cover Product being concealed by, but not limited to, vegetation, fabric, shelving, mud, snow, or dirt. Product must not be painted or limited warranty will be void.
12. This limited warranty does not cover exposure to corroding environments such as, but not limited to, petroleum and gasoline products, cleaning solvents, caustic pool chemicals, and marine air.
13. This limited warranty does not cover any cause not relating to Product defect.
14. THE REPAIR OR REPLACEMENT OF THE PRODUCT AS PROVIDED UNDER THIS LIMITED WARRANTY IS THE EXCLUSIVE REMEDY OF YOU, THE END USER, AS WELL AS ANYONE ELSE IN THE CHAIN OF TITLE OF THE PRODUCT, DOES NOT START A NEW LIMITED WARRANTY TIME PERIOD, AND IS IN LIEU OF ALL OTHER WARRANTIES (EXPRESS OR IMPLIED) WITH REGARD TO THE PRODUCT. IN NO EVENT SHALL CELLARCOOL BE LIABLE FOR INCIDENTAL, CONSEQUENTIAL, SPECIAL OR CONTINGENT DAMAGES FOR BREACH OF ANY EXPRESS OR IMPLIED WARRANTY ON THIS PRODUCT. THE IMPLIED WARRANTIES OF MERCHANTABILITY AND FITNESS FOR A PARTICULAR PURPOSE ARE HEREBY EXPRESSLY DISCLAIMED.
15. Some states do not allow the exclusion or limitation of incidental or consequential damages, or allow limitations on how long an implied warranty lasts, so the above limitations or exclusions may not apply to you. This limited warranty gives you specific legal rights, and you may have other rights, which vary from state to state.
16. Failure of the End User to comply with all of the Product Installation Requirements, Maintenance Requirements and End User Requirements may, at CellarCool's sole discretion, void this limited warranty.
17. No one has any authority to add to or vary the limited warranty on this Product.

3. Maintenance Requirements

The End User is responsible for checking the coils on the condenser unit and vacuuming them every three months to maintain them free of debris. It is the End User's responsibility to clean off any accumulated dust, lint, or other debris from the front and rear intake grills; failure to do this on a regular basis will restrict the airflow and may affect the Product's ability to function properly. Periodically cleaning the Product's vents will help assure maximum cooling efficiency. The drain tube must also be

checked and kept clean and free of debris and mold to maintain proper performance.

Mold is a natural living organism in the environment. It exists in the air in the form of microscopic spores that move in and out of buildings through doors, windows, vents, HVAC systems and anywhere else that air enters. Once it is discovered, mold must be addressed quickly and appropriately. Delayed or improper treatment of mold issues can result in costly and reoccurring repairs. If the End User suspects a mold problem, it is always best to hire a qualified and experienced mold remediation specialist.

4. Additional End User Costs And Responsibilities

Terms and conditions for replacing the Product that is being evaluated for limited warranty.

1. After evaluation by a certified HVAC/R technician and the Product is found to be irreparable in the field, contact CellarCool Customer Service to arrange for replacement under the warranty guidelines. When a claim for warranty is submitted for a condenser skid, the End User must purchase a new condenser skid from CellarCool at retail price. Upon installation of the new condenser skid by a certified HVAC/R Technician, the HVAC/R Technician must complete the Installation Checklist and End User must submit the Installation Checklist to CellarCool Customer Service for approval. The original condenser skid must be returned within 21 days to CellarCool for failure analysis. If the Installation Checklist is approved and the failure is evaluated as defective and not installation error or other reason, the End User will be refunded for the cost of the replacement skid.
2. If the Product failure is evaluated and it is determined that it is an installation error or other reason, all costs, including shipping will be the responsibility of the End User.

The following items are not covered under any warranty and are the sole responsibility of the End User:

- A. End Users should satisfy themselves that the Product they are purchasing is suitable for their particular needs and requirements, and thus no responsibility will be placed with CellarCool for the End User's decisions in this regard.
- B. End Users must assure that the product is installed by a certified HVAC/R technician. Failure to do so will result in Voiding the Limited Warranty.
- C. It is the End User's responsibility to secure safe haven/storage for ANY AND ALL items that are being kept and stored in the End User's wine cellar, including any Product. CellarCool takes no responsibility for the safety and preservation of the aforementioned items in the event that the environment becomes unsuitable to maintain a proper storage environment.
- D. End User is responsible for initial installation costs, including, but not limited to, labor costs and the cost of any additional parts necessary to complete the installation.
- E. End User is responsible for all costs incurred for the installation and/or removal of the Product, or any part thereof, unless such cost has been agreed by CellarCool to be a warranty repair prior to the work being performed.

5. Sales and Use Tax

CellarCool only collects California sales tax for orders shipped within the State of California; CellarCool does not collect sales tax for orders shipped to other states. However, the Purchaser and the End User may be liable to the taxing authority in their state for sales tax and/or use tax on the Product. The Purchaser and the End User should each check with their state's taxing authority for sales and use tax regulations.

6. Customer Service and Troubleshooting

CellarCool's customer service department is available to answer any questions or inquiries for End Users regarding a CellarCool Product, as well as to assist in performing basic troubleshooting, Monday through Friday, from 6:30 a.m. to 4:00 p.m. PST, at telephone number 1-800-343-9463. CellarCool reserves the right to have a certified, CellarCool-approved, HVAC/R technician go on site and inspect the product if the initial trouble shooting warrants further investigation. CellarCool Corporation is located at 1738 East Alpine Avenue, Stockton, California 95205.

7. Request for Product Evaluation and Repair Under Warranty

SPLIT SYSTEM FIELD SERVICE WARRANTY POLICY: This Policy is to clarify what falls under Warranty Service and what becomes the responsibility of the Owner. CellarCool ("manufacturer") strives to provide our customers with a superior Product and we back our Product with a Two Year Limited Warranty. Please review the CellarCool Product Terms and Conditions including Product Limited Warranty and Product Installation Requirements to ensure you have a complete understanding of our Policy and coverage of your Split System.

ARBITRATION: Any disputes arising out of or in connection with the installation and warranty of the Split System shall be referred to and finally resolved by a CellarCool approved Independent Certified HVAC/R Technician. The evaluation of the Technician on all issues or matters of identifying the responsible party (CellarCool or Installing Technician) shall be determined

in a written report. This report will be made available to all concerned parties. If discovered under warranty, CellarCool will assume the financial responsibility under their warranty guidelines. If the report finds the Owner's Installer as the responsible party, CellarCool will provide all documentation to the customer to substantiate the findings. This will include the Invoice from the Independent Certified HVAC/R Technician and the written report of the findings. The Owner will become responsible for payment directly to CellarCool for all charges incurred for repairs (labor, parts and shipping costs) on the Split System.

8. Miscellaneous Terms and Conditions

- A. Return Policy. All return inquiries must be made within thirty (30) calendar days of the original purchase of a Product and are subject to a twenty five percent (25%) restocking fee. Shipping costs are not refundable and the Purchaser is responsible for all return shipping costs (including customs fees and duties, if applicable).
- B. Security Interest. CellarCool retains a security interest in each Product until payment in full.
- C. Construction and Severability. Every provision of these Terms and Conditions shall be construed, to the extent possible, so as to be valid and enforceable. If any provision of these Terms and Conditions is held by a court of competent jurisdiction to be invalid, illegal or otherwise unenforceable, such provision will, to the extent so held, be deemed severed from the contract of sale between Purchaser and CellarCool, and all of the other non-severed provisions will remain in full force and effect.
- D. Governing Law/Choice of Forum. The laws of the State of California (without regard for conflicts of law) shall govern the construction and enforcement of the these Terms and Conditions of Sale (Sections 1 through 9 inclusive, including Product Limited Warranty And Product Installation Requirements), and further these Terms and Conditions of Sale shall be interpreted as through drafted jointly by CellarCool and Purchaser. Any dispute will be resolved by the courts in and for the County of San Joaquin, State of California, and all parties, CellarCool, Purchaser and End User, hereby irrevocably submit to the personal jurisdiction of such courts for that purpose. No waiver by CellarCool of any breach or default of the contract of sale (including these Terms and Conditions of Sale) concerning a Product will be deemed to be a waiver of any preceding or subsequent breach or default.
- E. Correction of Errors and Inaccuracies. These Terms and Conditions may contain typographical errors or other errors or inaccuracies. CellarCool reserves the right to correct any errors, inaccuracies or omissions, and to change or update these Terms and Conditions, at any time without prior notice.

9. Questions, Additional Information And Technical Assistance

- A. Questions. If you have any questions regarding these Terms and Conditions or wish to obtain additional information, contact us via phone at 1-800-343-9463 or please send a letter via U.S. Mail to:

Customer Service
CellarCool Corporation
1738 E Alpine Ave
Stockton, CA 95205

Email: support@cellarcool.com
Web: www.cellarcool.com

- B. Technical Assistance. CellarCool Customer Service is available Monday through Friday from 6:30 a.m. to 4:00 p.m. PST. The Customer Service representative will be able to assist you with your questions and warranty information more effectively if you provide them with the following:
 - 1. The model and serial number of your CellarCool UNIT.
 - 2. The location of the system and installation details, such as ventilation, construction of your wine cellar, and room size.

Model **WM&FD** _____ Serial Number **C** _____

Installed by _____ Date _____

CELLARCOOL

CellarCool
1738 E. Alpine Ave
Stockton, CA 95205
1(800) 343-9463
www.cellarcool.com