

HM & VM SERIES **TECH/OWNER'S MANUAL**

NOTICE: To activate the split system warranty, the installing certified HVAC/R service tech must complete the split system warranty checklist and send back to CellarCool.

CELLARCOOL

HMVM 092215

Conforms to ANSI/UL Std 427

Certified to CAN/CSA Std C22.2 No. 120

We manufacture, test and certify 100% of our wine cooling units in the USA. By sourcing the best components and closely controlling our manufacturing processes, we can assure the highest-quality, lowest defect manufacturing rates in the industry.

Copyright © 2011. CellarCool. All rights reserved.

This manual, the product design, and the design concepts are copyrighted by CellarCool, with all rights reserved. Your rights with regard to the hardware and manual are subject to the restrictions and limitations imposed by the copyright laws of the United States of America. Under copyright laws, this manual may not be copied, reproduced, translated, transmitted, or reduced to any printed or electronic medium or to any machine-readable form, for any purpose, in whole or in part, without the written consent of CellarCool. Every effort has been made to ensure that the information in this manual is accurate. CellarCool is not responsible for printing or clerical errors. CellarCool reserves the right to make corrections or improvements to the information provided and to the related hardware at any time, without notice. CellarCool are registered trademarks, and ECE is a trademark of CellarCool. All rights reserved. Mention of third-party products is for informational purposes only and constitutes neither an endorsement nor a recommendation. CellarCool assumes no liability with regard to the performance or use of these products.

10/28/14

HMVM 092215

TABLE OF CONTENTS

Quick Reference Guide	
System	2
Specifications	4
Introduction	5
Receiving & Inspecting The System	6
Before You Start	7
Preparing the Wine Cellar	8
Pre-Installation	9
Mounting & Air Flow	10
Ventilation	11
Installation	12
Line Set Piping Diagram	13
Horizontal Mount Installation	14
Vertical Mount Installation	20
Liquid Thermostat (Bottle Probe)	29
Remote Keypad Installation	30
Remote Keypad Functions	31
System Operation	34
2500 Evaporator Wiring DIAGRAM	36
2500 Evaporator Wiring DIAGRAM With Home Thermostat	37
2500 Condenser Wiring Schematic	38
3500 Evaporator Wiring DIAGRAM	40
3500 Evaporator Wiring DIAGRAM with Home Thermostat	41
3500 Condenser Wiring Schematic	42
5000 & 6500 Evaporator Wiring DIAGRAM	44
5000 & 6500 Wiring DIAGRAM With Home Thermostat	45
5000 Condenser Wiring Schematic	46
6500 Condenser Wiring Schematic	47
Maintenance Schedule	48
Troubleshooting Guide	49
Technical Assistance & Accessories	51
Installation Terms and Conditions	52

QUICK REFERENCE GUIDE (QR)

Horizontal Mount (HM) Front / Exploded View

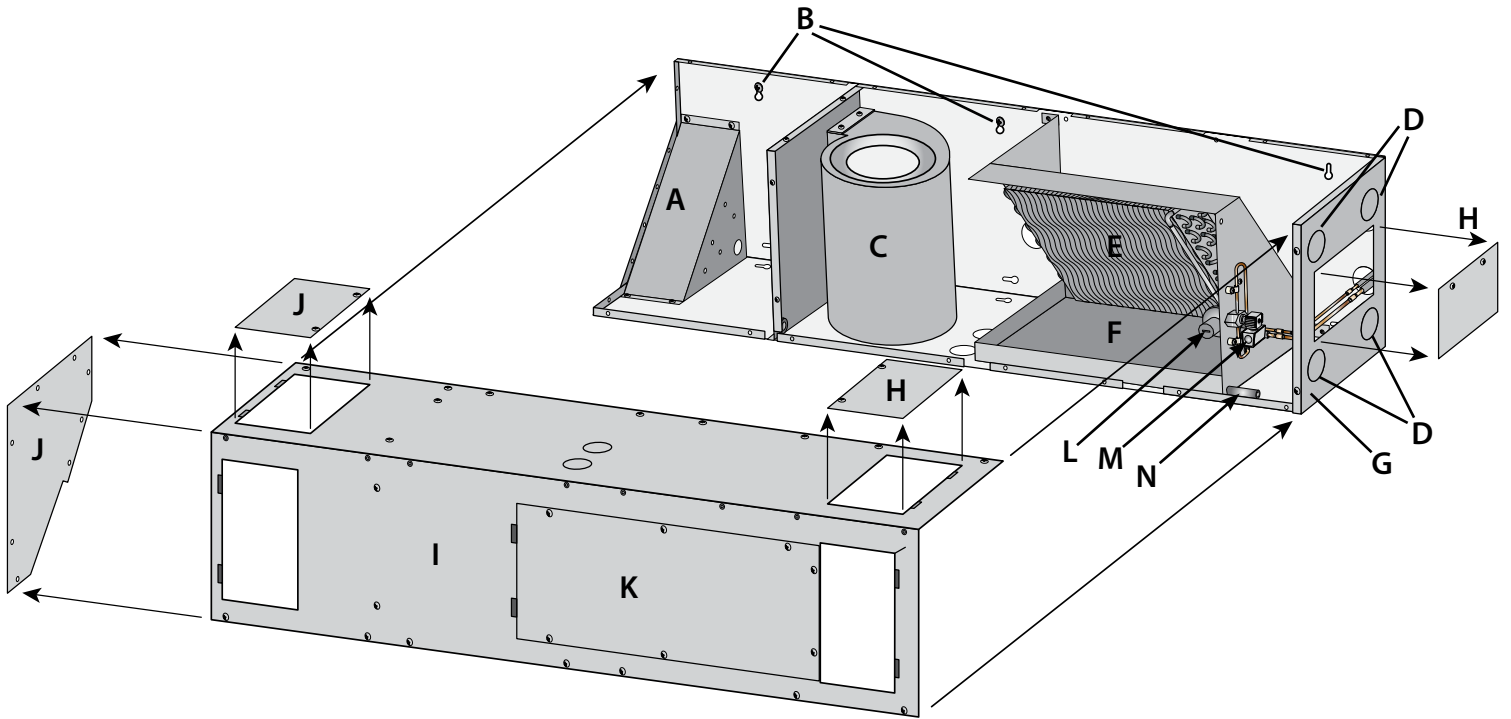

Q.R LEGEND

Letter	Label
A	Electrical Box
B	Key Hole
C	Blower
D	Line Set Knock Out
E	Evaporator Coil
F	Condensate Drip Tray

Q.R LEGEND

Letter	Label
G	End Cap
H	Return Air Panels
I	Evaporator Unit Cover
J	Supply Air Panels
K	Access Panel
L	Automatic Expansion Valve
M	Liquid Line Solenoid
N	Drain Line Connection
O	Wiring Knock Outs

HM Rear

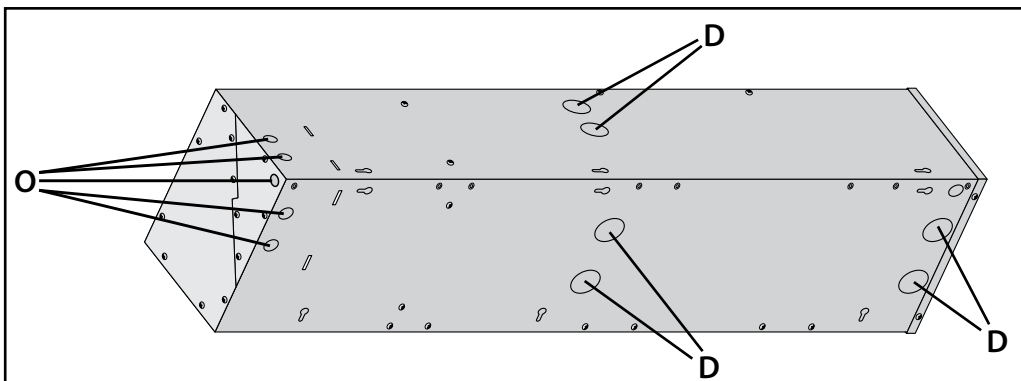

QUICK REFERENCE GUIDE (QR)

Vertical Mount (VM) Front / Exploded View

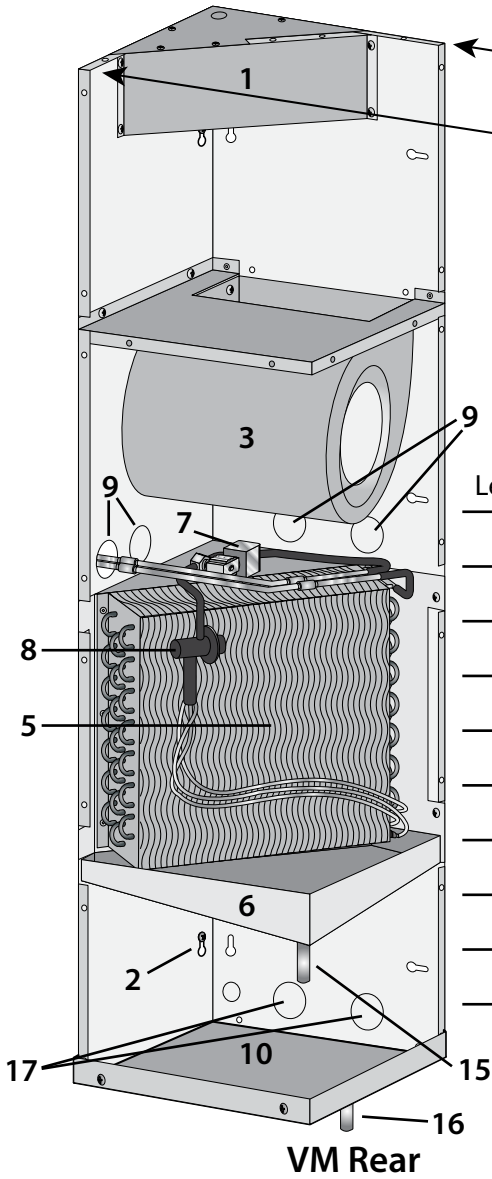

Q.R LEGEND

Letter	Label
1	Electrical Box
2	Key Hole
3	Blower
4	Optional Line Set Knock Out
5	Evaporator Coil
6	Primary Condensate Drip Tray
7	Solenoid
8	Automatic Expansion Valve
9	Primary Line Set Knock Outs
10	Secondary Drip Tray

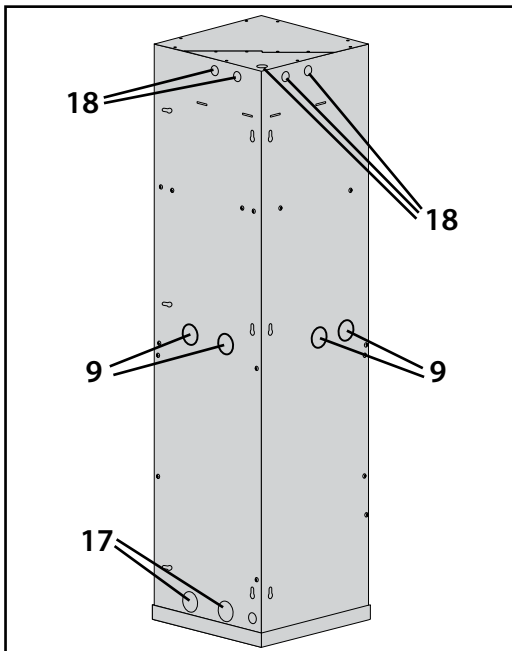
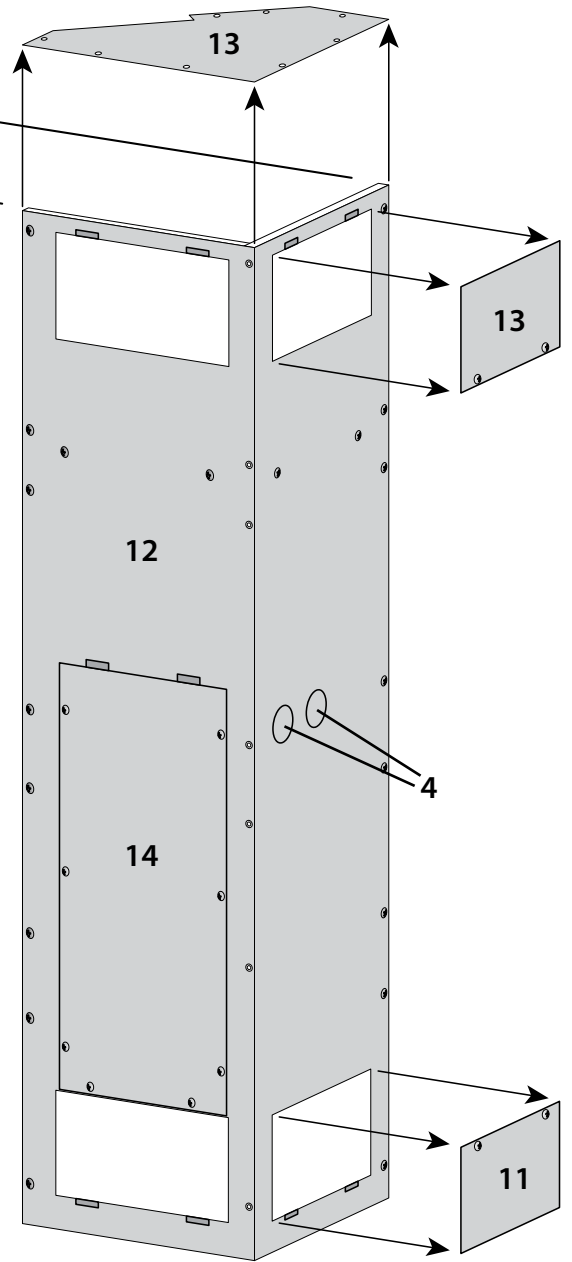

Q.R LEGEND

Letter	Label
11	Return Air Panels
12	Evaporator Unit Cover
13	Supply Air Panels
14	Access Panel
15	Primary Drain Line Connection
16	Secondary Drain Line Connection
17	Drain Line Knock Outs
18	Wiring Knock Outs

QUICK REFERENCE GUIDE

Layout

Refer to page 26 for complete listing of buttons and symbols.

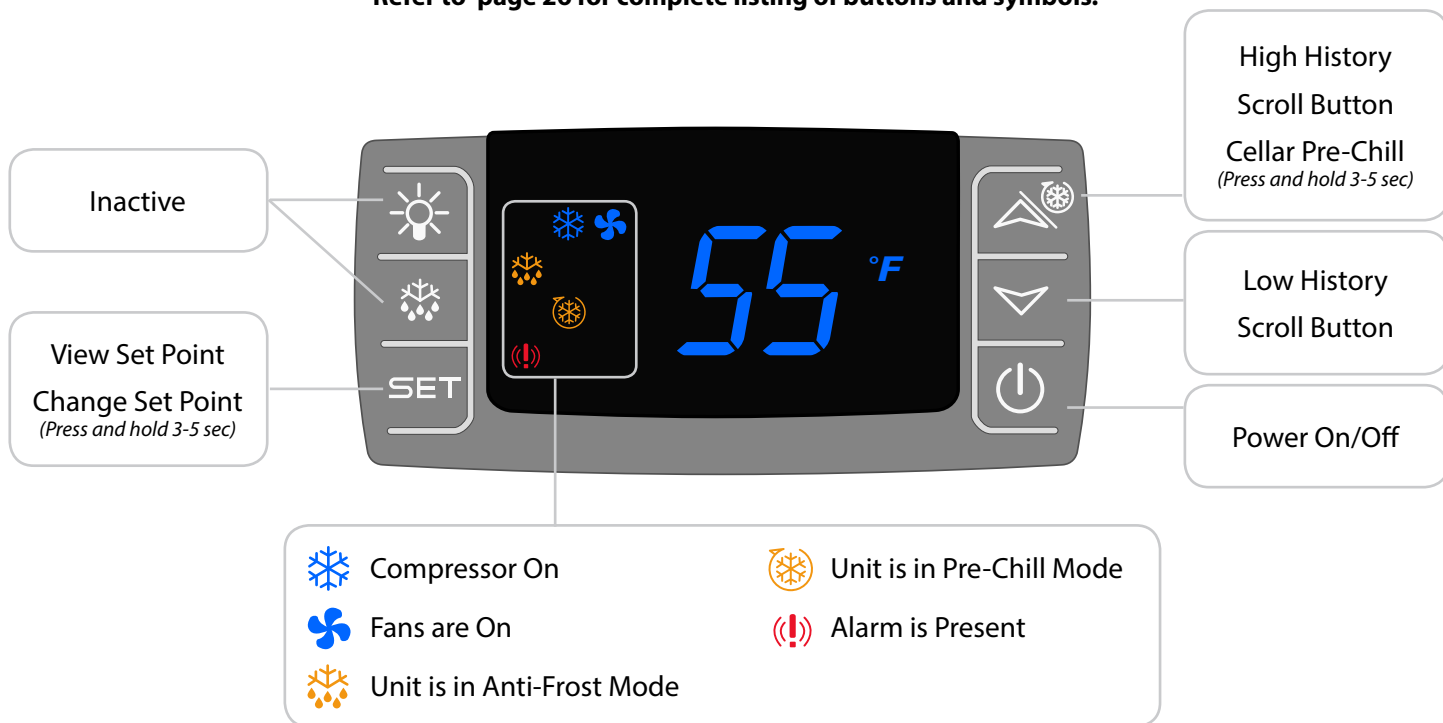

UNIT SPECIFICATIONS

Model	HM2500	HM3500	HM5000	HM6500	VM2500	VM3500	VM5000	VM6500
Cellar Size (cu. ft.)	650	1000	1500	2000	650	1000	1500	2000
Dimensions	12"H x 47"W x 12"D				47"H x 12"W x 12"D			
BTU _h with a 38° degree Evap Temp	3100	3500	4100	6500	3100	3500	4100	6500
CFM	214	252	456	456	214	252	456	456
Refrigerant	R-134a	R-134a	R-134a	R-134a	R-134a	R-134a	R-134a	R-134a
Condensing Unit HP	1/4	1/3	1/3++	1/2	1/4	1/3	1/3++	1/2
Voltage Rating (20 amp dedicated circuit required)	115V or 230V							
Weight (lbs)	60		73		60		73	
AMPS (Starting/Running)	1.4/1.04	1.4/1.14	2.5/2	2.5/2.1	1.4/1.04	1.4/1.14	2.5/2	2.5/2.1
dBA	48	56	56	59	48	56	56	59
Drainline	1/2" ID							
Installation	Evaporator coil installed in the cellar							
Thermostat	Optional							
Temp. Delta	55°F							
Warranty	2 year parts and labor / 5 year compressor							

INTRODUCTION

Customer Service

Thank you for purchasing a CellarCool cooling system. We strive to provide the highest quality products and the best possible customer service. If you have any questions about your system, please call us at 1-855-235-5271 or visit cellarcool.com.

Using the Manual

This Owners Manual is intended to assist in the proper installation and maintenance of the cooling system. In order to ensure the longevity of your cooling unit, the equipment should be installed properly and have a proper care and maintenance schedule (as outlined in page 39). Please read and review this manual carefully and keep it for future reference.

What Is the CellarCool Cooling System?

The CellarCool cooling system is a specialized refrigeration system designed for one purpose only: to maintain the optimal temperature and humidity levels conducive to the proper storage and aging of fine wines. This system produces minimal in-cellar noise and has the most lenient exhaust requirements. An exterior housing is required for outdoor condensing unit installations.

How Does the Cooling System Work?

Similar to the air conditioning systems used for homes, the evaporator and condensing units are installed in separate locations and are connected by a refrigerant line set. The evaporator portion is commonly installed in the wine cellar to remove heat and the condensing unit either outside or in a remote indoor location where the heat is expelled.

Temperature Setting

The CellarCool system, with a CellarCool controller, can be set at any temperature within the acceptable wine-aging range of 50°F to 67°F. It is designed to cool the cellar up to 55°F cooler than the ambient temperature of the space to which the condensing unit is installed.

Sizing the Unit to the Room

The specification chart will provide information on the units room size cooling capacity. There are circumstances in which a cellar design may require a larger unit due to some existing design restrictions. In such a case, we recommend that the customer consider purchasing a unit with a larger capacity to compensate for the design limitations. Issues such as glass doors, concrete, or brick walls and floors may seem adequate but do not offer the insulation capacity required to maintain the optimum environment.

WARRANTY REGISTRATION

In order to activate the warranty of your system, the Verification and Operational Documentation must be completed by the certified refrigeration technician installing your system and returned via mail, fax, or e-mail.

Mail to:
CellarCool
ATTN: Warranty Registration
1738 E. Alpine Avenue
Stockton, CA 95205-2505
USA

Fax to:
209.466.4606
OR

Scan and email to:
warranty@cellarcool.com

RECEIVING & INSPECTING THE SYSTEM

Receiving and Inspecting the System

- Lift only at the designated hand hold locations on the shipping container or fully support the unit from underneath. A shipment may include one or more boxes containing accessories.
- Open the container, and inspect the system for any obvious signs of damage or mishandling.
- If possible write any discrepancy or visual damage on the Bill of Lading before signing. If unable to note on the BOL contact Customer Service at 1.855.235.5271.
- Place the box containing the unit on a tabletop to prepare it for testing prior to installing.
- Sit upright for 24 hours.

Note: CellarCool units are manufactured in the USA and tested prior to shipment.

Review the Packing Slip to Verify Contents

- Check the model number to ensure it is correct.
- Check that all factory options ordered are listed.

If any items listed on the packing slip do not match your order information, contact CellarCool Customer Service immediately.

Check the Box for the following contents:

<p>HM 2500S / HM 3500S / HM 5000S / HM 6500S</p> <p>Full Split System Purchase:</p> <ul style="list-style-type: none"> • Evaporator Unit • Condensing Unit <p>Accessory Kit:</p> <ul style="list-style-type: none"> • CellarCool Owner’s Manual • Hose Clamp(1) • 1 3/4” Hex-Head Screws (6) • 10’ Drain Line tube (1) • Remote Key Pad • 50 ft Beldin Cable • Filter Drier • Sight Glass 	<p>VM 2500S / VM 3500S / VM 5000S / VM 6500S</p> <p>Full Split System Purchase:</p> <ul style="list-style-type: none"> • Evaporator Unit • Condensing Unit <p>Accessory Kit:</p> <ul style="list-style-type: none"> • CellarCool Owner’s Manual • Hose Clamp(1) • 1 3/4” Hex-Head Screws (6) • 10’ Drain Line tube (1) • Remote Key Pad • 50 ft Beldin Cable • Filter Drier • Sight Glass
<p>HM 2500C / HM 3500C / HM 5000C / HM 6500C</p> <p>Evaporator Only Purchase:</p> <ul style="list-style-type: none"> • Evaporator Unit <p>Accessory Kit:</p> <ul style="list-style-type: none"> • CellarCool Owner’s Manual • Hose Clamp(1) • 1 1/4” Hex-Head Screws (6) • 10’ Drain Line tube (1) 	<p>VM 2500C / VM 3500C / VM 5000C / VM 6500C</p> <p>Evaporator Only Purchase:</p> <ul style="list-style-type: none"> • Evaporator Unit <p>Accessory Kit:</p> <ul style="list-style-type: none"> • CellarCool Owner’s Manual • Hose Clamp(1) • 1 1/4” Hex-Head Screws (6) • 10’ Drain Line tube (1)

Please leave the unit in its original box until you are ready for installation. This will allow you to move the product safely without damaging it. When you are ready to remove the product from the box, refer to the installation instructions.

TIP: Save your box and all packaging materials. They provide the only safe means of transporting/shipping the unit.

BEFORE YOU START

1. **Inspect the system before installation.** If damage is found, please contact your distributor or CellarCool Customer Service at 1.855.235.5271.
2. The system **requires a dedicated 115-volt 20-amp circuit.** Use a surge protector with the unit. **Do not use a GFI** (Ground Fault Interrupter) line.
3. It is **REQUIRED** to **install a drain line** to remove condensation from the evaporator unit.
4. The system is intended **for use in properly designed and constructed wine cellars.** Hire a professional wine storage consultant with a valid contractor's license to build your wine cellar.

Note: If the unit ducted the evaporator must be fully wrapped with insulation to prevent sweating.

If you encounter a problem with your CellarCool system, please refer to the Troubleshooting Guide on page 30. If you have any further questions, concerns, or need assistance, please contact CellarCool's Customer Service at 1.855.235.5271. Please be sure all testing has been completed prior to contacting Customer Service. Please have your results ready for your representative.

PREPARING THE WINE CELLAR

The performance and life of your system is contingent upon the steps you take in preparing the wine cellar.

Note: Improperly preparing your enclosure or incorrectly installing your unit may cause unit failure, leaking of condensation, and other negative side effects.

IT IS HIGHLY RECOMMENDED THAT YOU OBTAIN THE ASSISTANCE OF A WINE STORAGE PROFESSIONAL.

Wine storage professionals work with licensed contractors, refrigeration technicians, and racking companies to build well-insulated, beautiful, and protective wine cellars. CellarCool has put together some useful tips to assist in the installation process. Our recommendations are meant to act as a guide in the process of building a proper enclosure. Your intended location may have specific needs that we do not address.

Wall & Ceiling Framing

Build wine cellar walls using standard 2x4 or 2x6 construction methods and ceiling joists following the guidelines of local and state codes in your area. As a general rule, the thicker the walls and the higher the insulation value in your cellar, the better it will be at maintaining a consistent temperature.

Insulation

Insulation is **REQUIRED** with the use of the CellarCool product. Standard fiberglass or rigid foam insulation is normally used in cellar construction or, in some cases, "blown-in" insulation is used. It is very important that all walls and ceilings are insulated to keep the cellar temperature as consistent as possible during the summer and winter months. The R-value, or quality of insulation, is determined by the rate at which heat passes through the insulation. The higher the R-value, the more resistant the insulation is to conducting heat. Using higher R-values in insulation will lower your operating costs and unit run time. (R-13 minimum, R-19 recommended, R-30 for ceiling and exterior walls.)

Vapor Barrier

Water vapor creates its own pressure, separate from the air pressure, and will intrude into colder/drier areas. A vapor barrier is **REQUIRED** to prevent the intrusion of water vapor so that the cellar can be kept at the correct temperature and humidity. 6 mm plastic sheeting (recommended) should be applied to the warm side of the cellar walls. The vapor barrier must also be applied to the outside walls and ceiling. If it is impossible to reach the outside, then the plastic must be applied from within the cellar. The most common method is to wrap the entire interior, leaving the plastic loose in the stud cavity so the insulation can be placed between each stud. All of the walls and ceiling must be wrapped in plastic for a complete vapor barrier.

In areas of high humidity, such as Southern and Gulf States, the vapor barrier will prevent infiltration of warm moist air. The moist air can cause mold to form, and standing water in drain pans promote microbial and fungal growth that cause unpleasant odors and indoor air quality problems. If mold is found, remove it immediately and sanitize that portion of the unit. High humidity significantly increases the heat load on the refrigerant system.

Any break in the vapor barriers (cut, nail hole, over-lapping, etc) will allow a moisture leak and must be sealed. Electric conduit is a "duct" for vapor to travel in. The conduit should be caulked and sealed on the warm air end.

PRE-INSTALLATION

General Installation Guidelines and Instructions

CellarCool requires that a certified HVAC technician install and charge all split systems. Please take a moment to review state and city building codes to ensure the safe and proper installation of the system.

Electrical Needs

The Condensing Unit requires a dedicated 115-volt 20-amp circuit. The unit draws a large amount of amps at initial start up. By designating a dedicated circuit breaker, you will guarantee the unit has enough power to run effectively. Contact an electrician for assistance with the installation of this dedicated electrical circuit:

- Match the electrical outlet to the plug provided on the unit.
- Provide a dedicated circuit and wiring for the unit.
- Provide a weatherproof plug for units connected outside.

Plug your unit into a surge protector or power conditioner. As with any sensitive electrical equipment, the electrical equipment may be damaged by power surges and spikes. Power surges and spikes are not covered under warranty.

WE RECOMMEND THAT YOU DO NOT USE A GROUND FAULT INTERRUPTER (GFI) WITH THIS PRODUCT.

In case the system should lose power, check the home/main circuit breaker. If the system does not respond properly, refer to the Troubleshooting section on page 30.

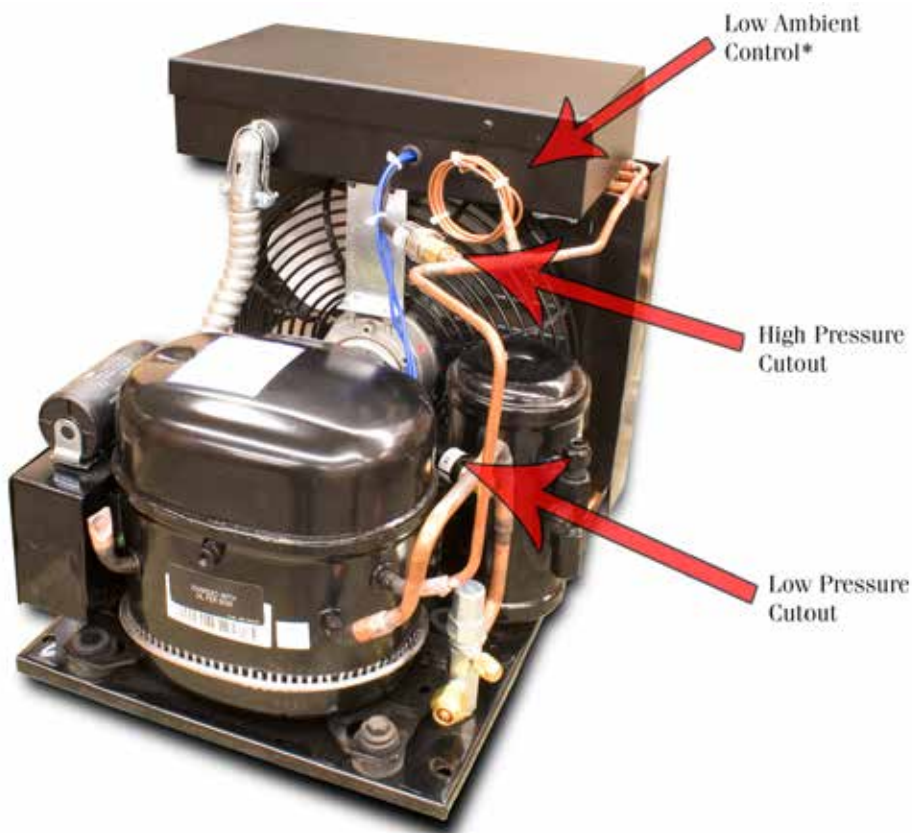



Unobstructed Airflow

Unobstructed airflow to and from the system is critical for the system's overall performance and life-span. A minimum three-foot clearance (five foot is ideal) area is crucial. The air the fans blow needs to circulate and either dissipate or absorb heat from the space, the more air to exchange the more efficient the system will operate.

Note: Avoid attempting to camouflage the unit. This will restrict airflow and thus the systems's ability to work efficiently.

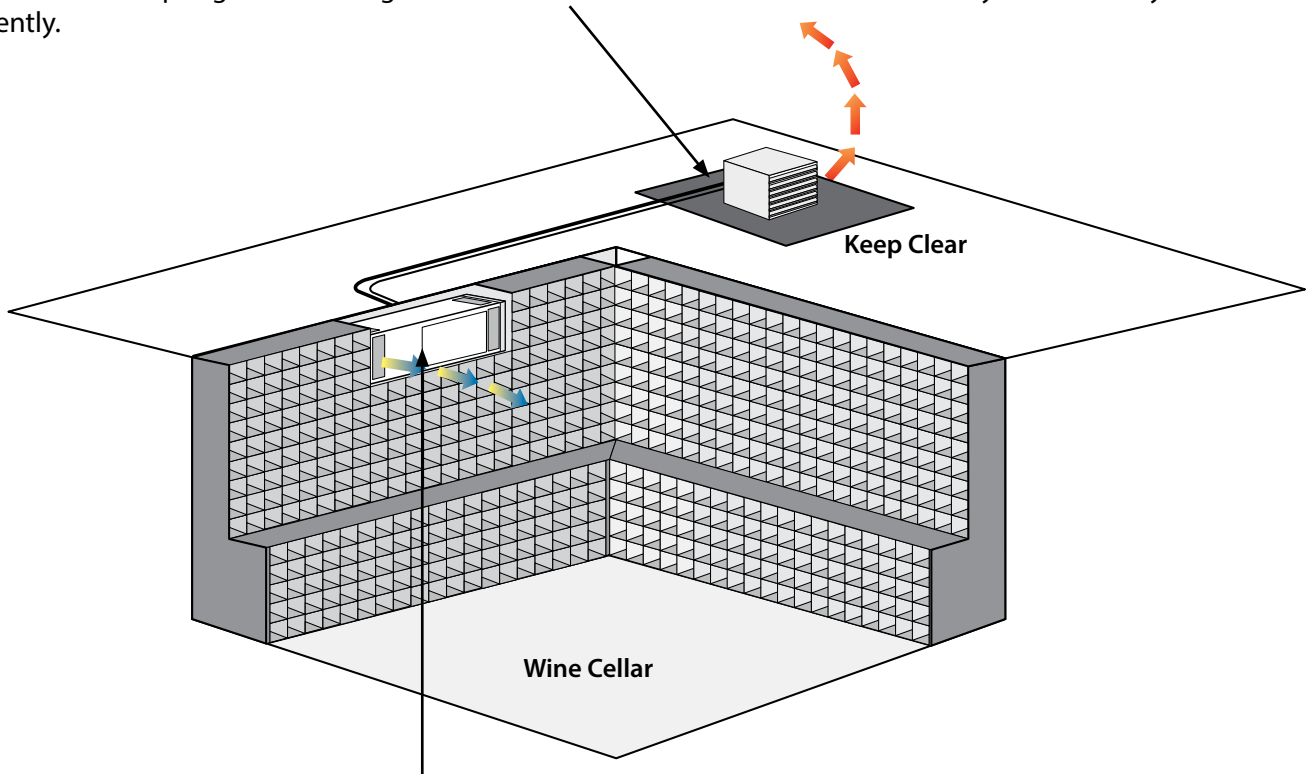

Mounting the Unit

The evaporator unit must be mounted within 18" of the top of the room in order to achieve sufficient cooling. As the room cools down, the warm air will rise to the ceiling. Mounting the unit high in the room will create a consistently cool environment by capturing the warm air and replacing it with cool air. Mounting the unit low in the room will result in a temperature variation in the room due to the unit's inability to draw warm air from the ceiling of the cellar to the unit itself, and cold air settling to the floor.

Door and Door Seal

An exterior grade (1 3/4") door must be installed as a cellar door. It is very important that weather stripping is attached to all 4 sides of the doorjamb. A bottom "sweep" or threshold is also required. The door must have a very good seal to keep the cool cellar air from escaping out of the cellar. One of the most common problems with cooling systems running continually is due to the door not sealing properly. **In cases where glass doors are used and the room size is close to the recommended system size, the next larger size CellarCool system should be used.** This will compensate for the insulation loss due to the lower insulating rating of glass.

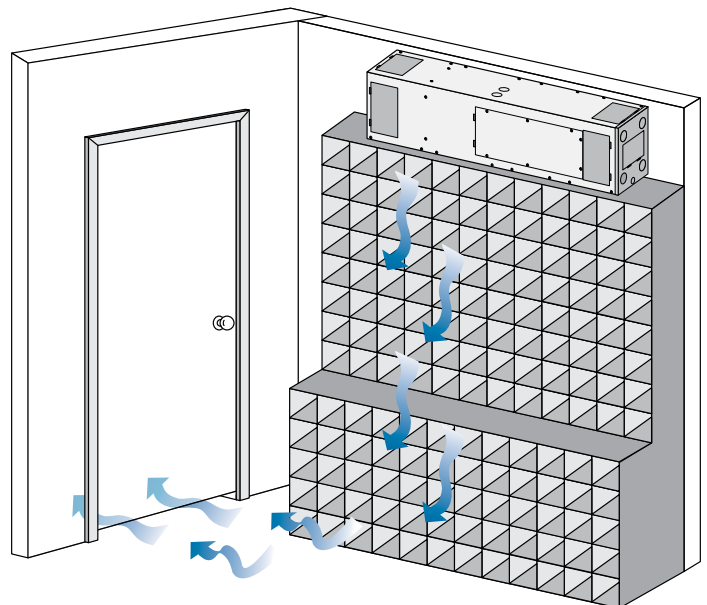

Ventilation

The necessity of dissipating heat away from the condensing unit is critical to the performance and cannot be overstated. As the system operates and cools, a greater amount of heat is generated on the condensing side of the system. Adequate ventilation is required in order to dissipate heat away from the condensing unit. If ventilation is inadequate, the exhaust will heat up the area or room and adversely affect the systems ability to cool. In some cases, it may be advisable to install a vent fan to dissipate heat within the exhaust area on the condensing side of the system. However, you must have a fresh air inlet as well.

Note: If you are unsure about having adequate ventilation in your install location, please contact us to assess your specific installation at support@cellarcool.com or 1.800.343.9463.

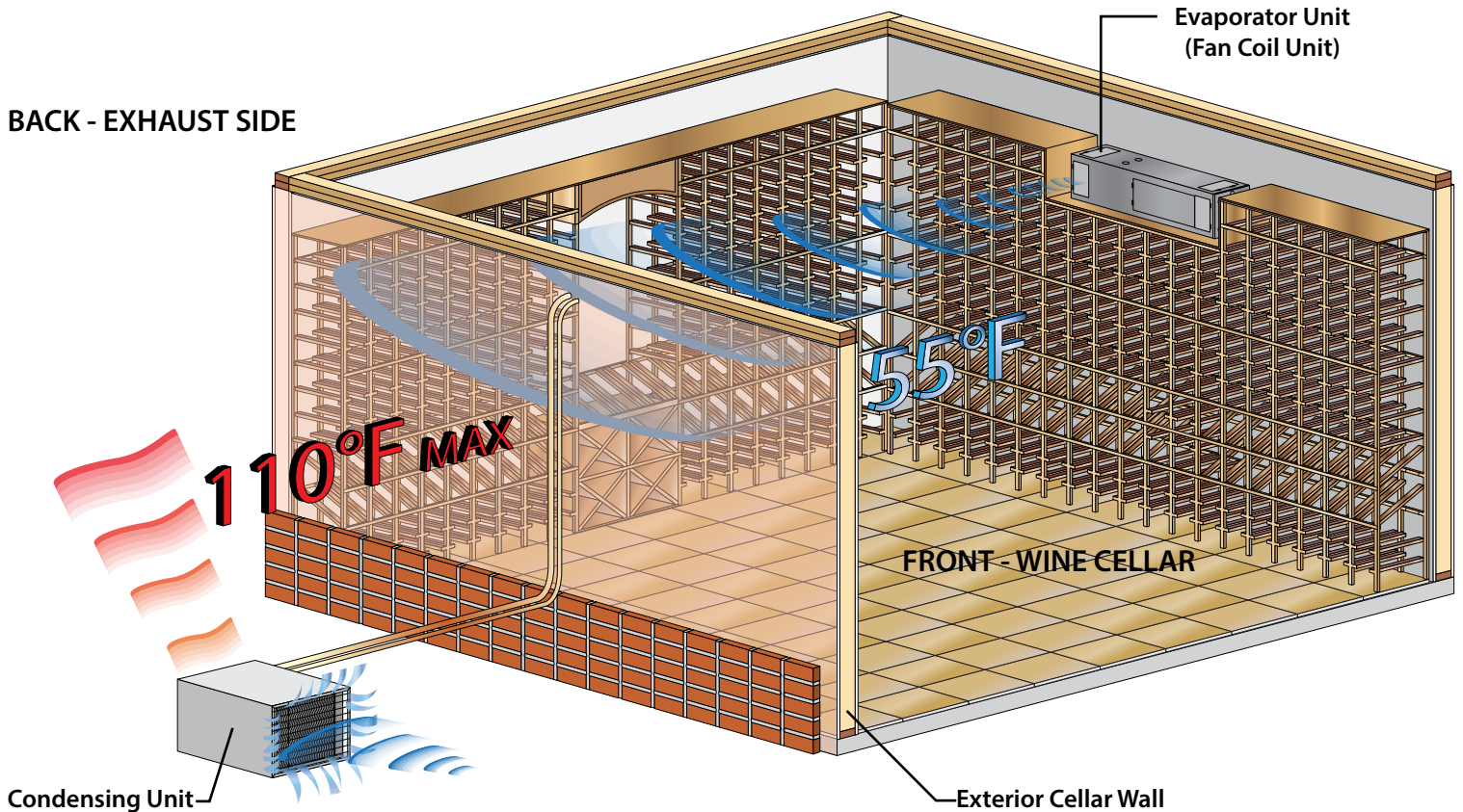

Ambient Temperature Factor

The cooling system has the ability to cool a wine cellar efficiently to 55°F as long as the ambient temperature of the area that it is exhausting to does not exceed 110°F. Therefore, you want to exhaust the condensing unit in a space which will not exceed 110°F. Otherwise the system will not have the capacity to keep the wine at a desirable 55°F.



Warning, allowing your system to operate in high ambient temperatures for extended periods of time will greatly decrease the life of your system and void your warranty.



CONDENSING UNIT INSTALLATION

Installing the Condensing Unit

The condensing unit can be mounted inside a utility area of the home or outside utilizing the required outdoor condensing unit housing. The condensing unit requires a dedicated 20 amp circuit, non-GFI. Make sure there is a minimum three-foot horizontal clearance in front and rear of the unit. The unit may either be hard wired or plug-in depending on local electrical codes.

Indoor Condensing Unit Installations: Indoor installations require special consideration, as there must be adequate ventilation to dissipate the heat created during normal operations. An exhaust port with fan may need to be installed to ensure that heat is effectively removed from the utility room. A return grille or provision for 500 - 600 cfm of cool air to enter the room to replace the exhausted air will accomplish this. Unobstructed airflow to and from the unit is a critical factor in the unit's overall performance. Make sure there is a minimum three-foot horizontal clearance in front and rear of the unit. This will assure that the unit can move the air around the room in an efficient manner.

Outdoor Condensing Unit Installations. You must utilize the exterior condensing unit housing for outdoor installations. Place the condensing unit on a solid foundation in a location with adequate ventilation. There should be three feet of clearance in the front and rear of the unit and one foot on each side. The unit should be elevated 18 inches in order to avoid any possible flooding or damage by animals, and should be clear of leaves, dirt, and other debris.

High Pressure Cutout, Low Ambient Control, Fan Cycling Switch:

The condensing units are equipped with these safety features to protect the system and ensure proper operation. The low ambient control is designed to cycle the condenser fan in low ambient conditions. It is set from the factory at 175 psig cut-in and 75 psig differential. This setting should be confirmed by the installing technician once the system is operational. If your condensing unit is not equipped with an adjustable low ambient control, it will have a pre-set fan cycling switch to serve the same purpose.

The high pressure Cutout is designed to turn off the system in the event that the condensing pressure exceeds 300 psig.

Wiring the Evaporator Unit

The compressor is controlled by a "pump down cycle," therefore, no wiring between the condensing unit and evaporator unit is necessary. A low pressure switch in the condensing unit turns the compressor on and off. Wire the system in accordance with local codes and the enclosed wiring diagrams (page 25). The evaporator unit requires a standard 20 amp circuit, non-GFI. A dedicated circuit is not mandatory, but recommended.

HM/VM xxxxC Locate the 5 knock outs and determine which knock out is optimal for routing in line voltage and control voltage. Using a 24v thermostat: Install a 115 v to 24 v step down transformer, a 24v relay for the fan, and a 24v relay for the solenoid coil. Wire in accordance with local building codes. Use the provided schematic and see diagram for wiring information.

Refrigeration Lines & Charging the System

See the line diagrams on the next page and the advanced installation guidelines section starting on page 14.

LINE SET PIPING DIAGRAMS

It is required to size the suction line tubing according to this chart.

Model	Line Set Length	<25ft			26-50ft			50-100ft		
	Vertical Rise	<3ft	3-10ft	>10ft	<3ft	3-10ft	>10ft	<3ft	3-10ft	>10ft
HM/VM 3500	Horizontal Tubing	1/2"						5/8"		
	Vertical Rise	3/8"						5/8"	1/2"	
HM/VM 6500	Horizontal Tubing	1/2"			5/8"					
	Vertical Rise	3/8"			1/2"					

SINGLE FAN COIL PIPING SYSTEM

CONDITION: CONDENSING UNIT BELOW OR CLOSE TO SAME ELEVATION AS FAN COIL UNITS

LEGEND	
LLS	Liquid Line Solenoid
AXV	Automatic Expansion Valve
COMP	Compressor
REC	Receiver
EVAP.	Evaporator
O.D.	Outer Diameter

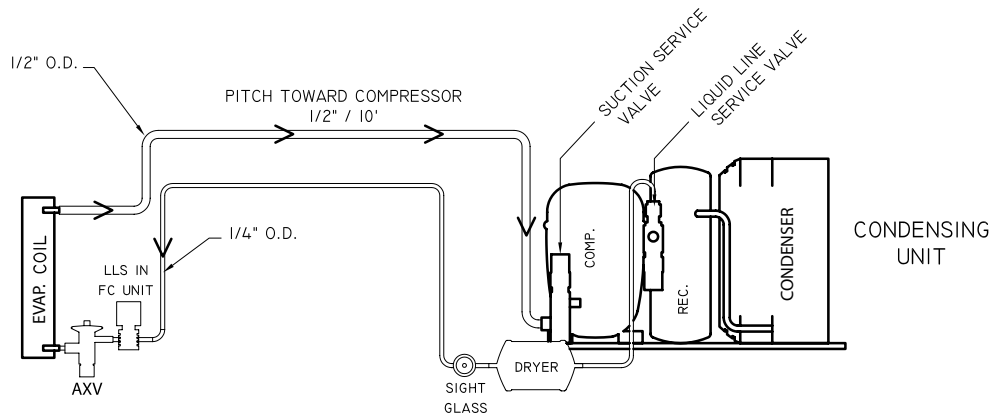

SINGLE FAN COIL PIPING SYSTEM

RECOMMENDED REFRIGERANT PIPING DESIGN FOR CONVENTIONAL FACTORY SUPPLIED FAN COIL AND AIR COOLED CONDENSING UNIT COMPONENTS. REFRIGERANT LINE LENGTHS IN EXCESS OF 90' NOT RECOMMENDED.

THIS DRAWING APPLIES TO CONDENSING UNIT LOCATION AT OR BELOW THE ELEVATION OF THE FAN COIL UNIT. SUCTION PIPE TO BE INSULATED WITH 1/2" WALL INSULATION (ARMAFLEX BRAND) OR EQUAL.

SINGLE FAN COIL PIPING SYSTEM
CONDITION: CONDENSING UNIT ABOVE FAN COILS AND VERTICAL PIPES HAVE GREATER THAN 3' RISE.

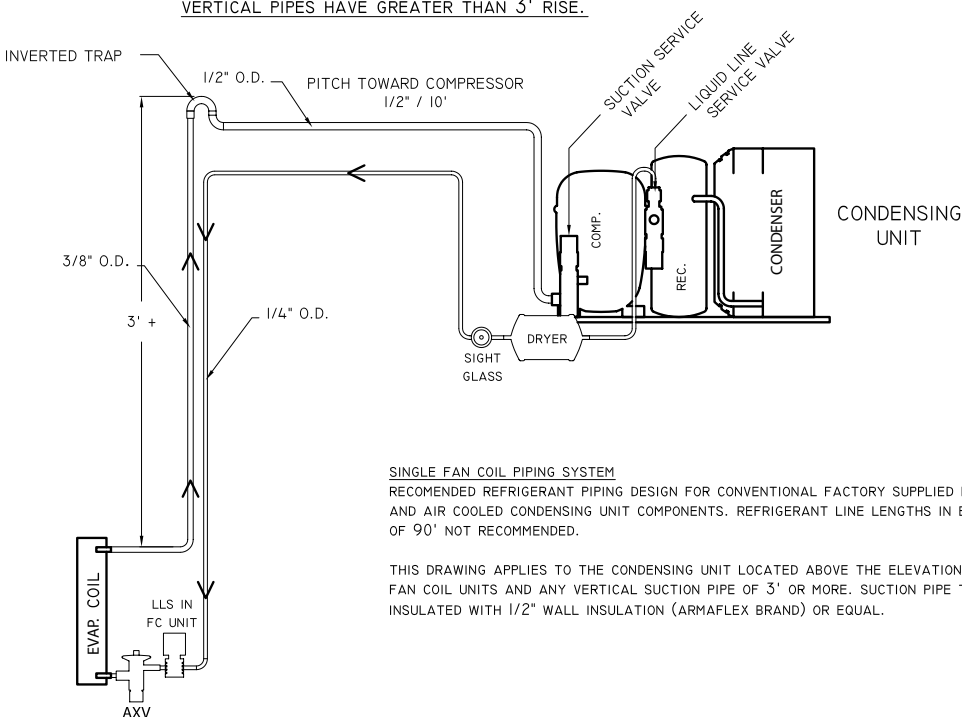

SINGLE FAN COIL PIPING SYSTEM
RECOMMENDED REFRIGERANT PIPING DESIGN FOR CONVENTIONAL FACTORY SUPPLIED FAN COIL AND AIR COOLED CONDENSING UNIT COMPONENTS. REFRIGERANT LINE LENGTHS IN EXCESS OF 90' NOT RECOMMENDED.

THIS DRAWING APPLIES TO THE CONDENSING UNIT LOCATED ABOVE THE ELEVATION OF THE FAN COIL UNITS AND ANY VERTICAL SUCTION PIPE OF 3' OR MORE. SUCTION PIPE TO BE INSULATED WITH 1/2" WALL INSULATION (ARMAFLEX BRAND) OR EQUAL.

PREPARING THE INSTALLATION LOCATION

Horizontal Mount

Minimum Tools Needed



Level

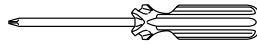

Screwdriver

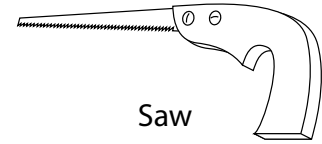

Saw

Locate the desired installation location (no lower than 18" inches from the ceiling). Using a stud finder locate the center of two studs.

Using a level and a pencil, mark a vertical center line down each stud and a perpendicular line through both of the center lines, no less than 1 1/2" and no more than 18" from the ceiling.

Locate the desired line set entry hole (see diagram below). Measure the hole's location with the origin at the center, vertical key hole on the rear of the evaporator unit.

Make the same measurement on the wall with the origin at intersection of the horizontal and center line. Using a saw, cut out a small square followed by running the line set through the hole.

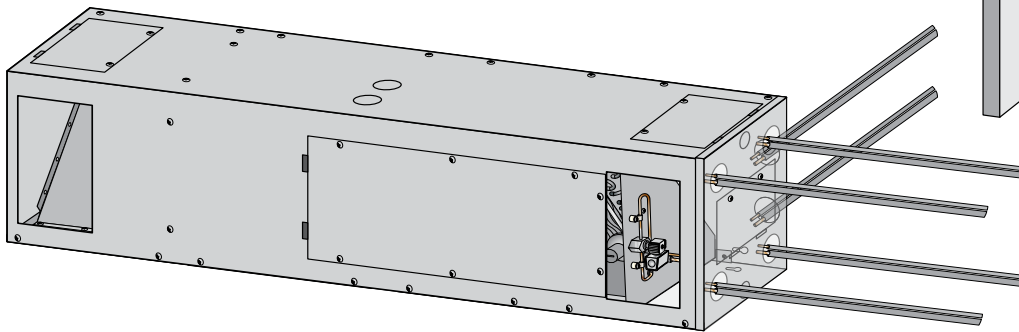
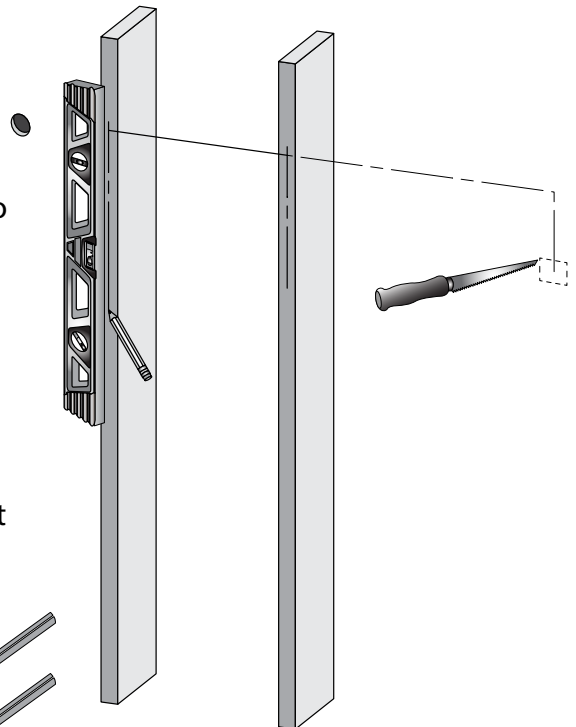

Locate the desired wiring entry hole (see diagram below). Measure the hole's location with the origin at the center, vertical key hole on the rear of the evaporator unit.

Make the same measurement on the wall with the origin at intersection of the horizontal and center line. Using a whole saw, cut out a small 1" diameter whole followed by running all necessary wires through the whole.

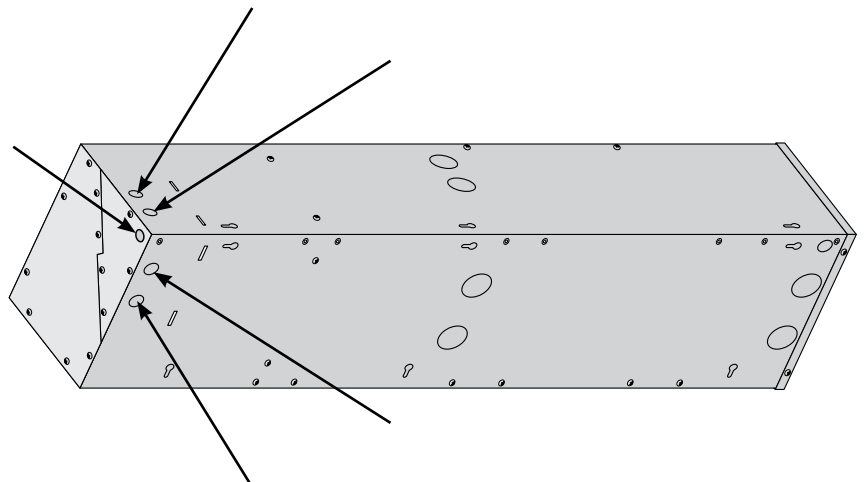

HORIZONTAL MOUNT INSTALLATION

Remove 30 8-18x3/8" Phillips Pan Head screws followed by sliding the cover off of the evaporator unit.

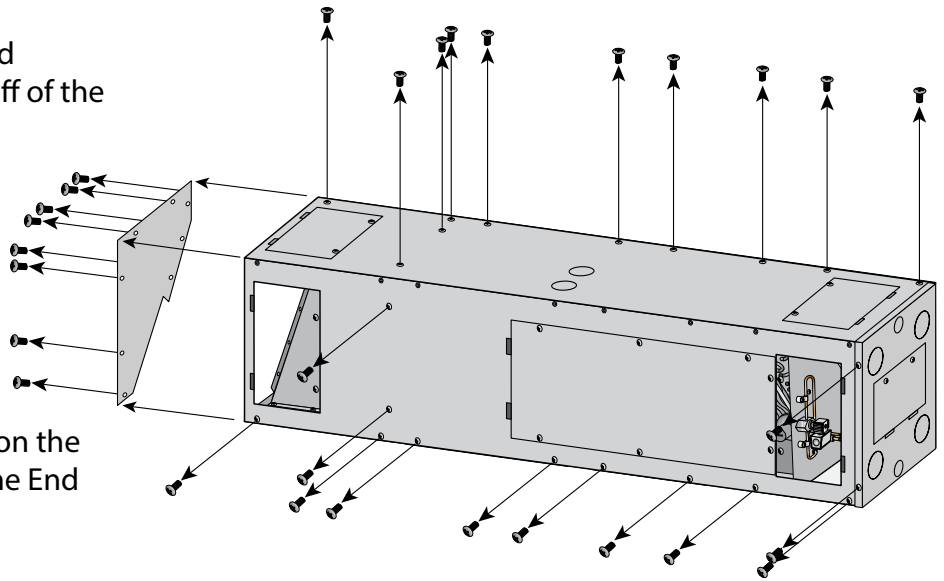

Note: Do not remove the two screws on the rear of the evaporator unit securing the End Cap.

Drill two 5/32" pilot holes in the line intersections (make sure they are 16" on center). Screw in one of the provided 1 3/4" Hex Head screws in the right hole.

Install the evaporator unit by aligning the center vertical key hole with the screw on the wall. Place unit on the screw and tighten down.

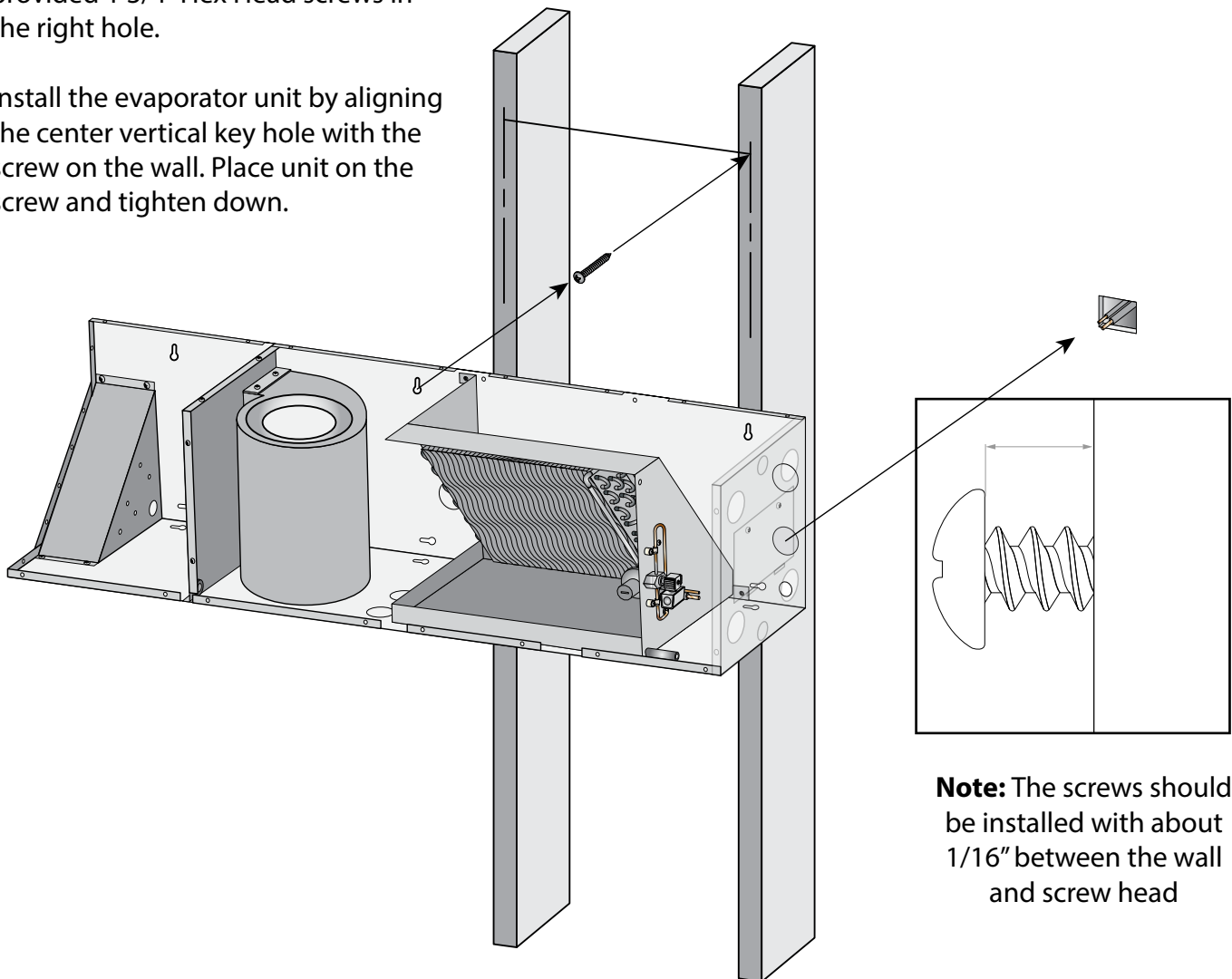

Note: The screws should be installed with about 1/16" between the wall and screw head

HORIZONTAL MOUNT INSTALLATION

Secure the unit by installing another screw into the left pilot hole after aligning it with the left vertical key hole. Tighten both screws when the unit is already in place.

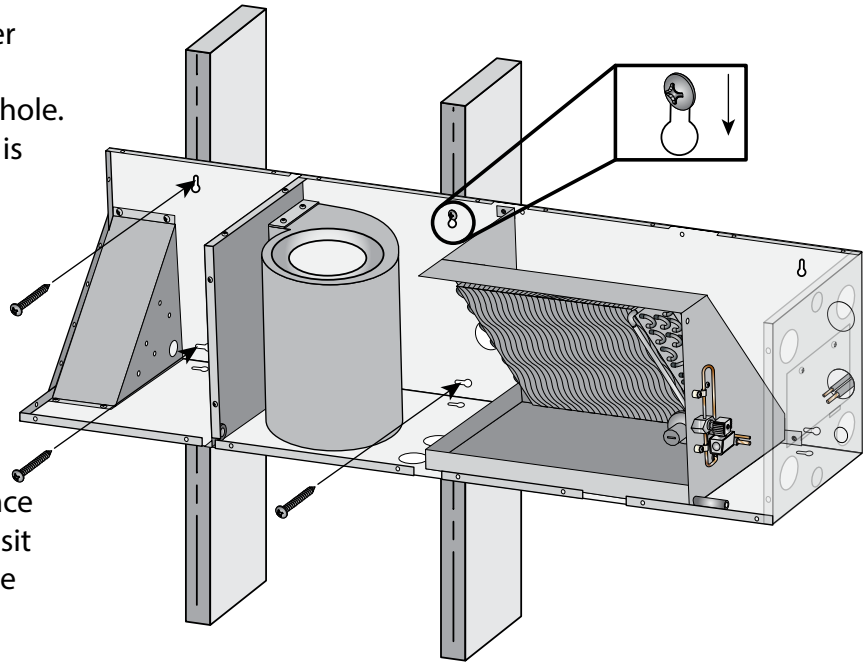

Ensure the unit is installed level. Once unit has been checked/adjusted to sit level, install one screw in each of the bottom key hole cut outs.

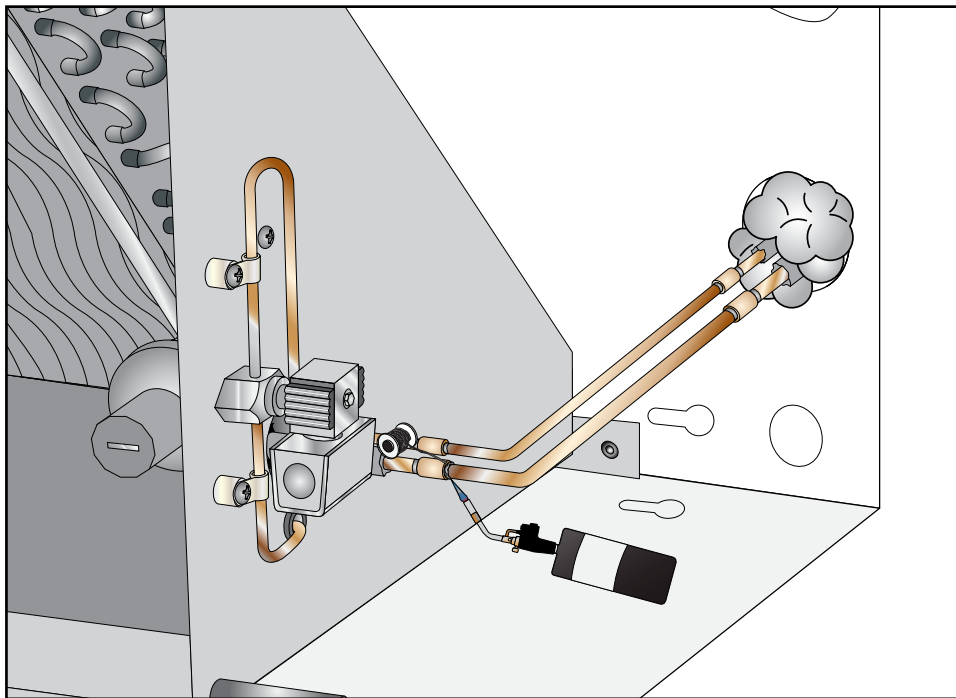

Using proper practices and procedures for brazing refrigeration tubing: Purge nitrogen in to the system, braze the large tube of the line set to the suction line outlet and small tube to the liquid line inlet at the evaporator. Pressurize the system to 200 PSIG for 30 minutes to verify the system is sealed. Once complete, insulate the exposed suction line in the evaporator unit using Armaflex Insulation.

Note: If the liquid line is going to sit in an area with direct sunlight or high ambient temperatures, insulation on the liquid line is recommended. DO NOT INSULATE the suction line and liquid line with direct copper to copper contact. Each line needs to be insulated individually. Seal entry hole using expanding foam insulation.

HORIZONTAL MOUNT DRAIN LINE

Condensate Drain Line Tube

The condensate drain line tube is used to remove excess condensation from the evaporator unit to a proper discharge location. It is important that the drain line tube is properly connected and used to prevent leakage and other problems associated with excess condensation.

Failure to use the condensate drain line tube will void the warranty on the unit.

Drain Line

All systems come with a drain line for removal of excess condensate. It is mandatory to install the drain line whether it leads through the wall and out of the cellar or remains inside the cellar. During operation, the cooling system will condense excess water from the air in order to maintain the proper level of humidity within the cellar. However in extreme humidity, additional condensate will be removed. Thus the drain line will prevent overflow and leaking by allowing for discharge of the additional condensate.

Attach the provided tube to the desired drain line option followed by running the line to an appropriate dispense area.

Place hose clamp around drain line. Slide the drain line over the tube at the outlet of the drip tray. Install the provided hose clamp on the drain line where the drain line is attached to the tube. This will ensure the tube does not get disconnected.

THROUGH THE WALL DRAIN LINE OPTION 1

INSIDE CELLAR DRAIN LINE OPTION 2

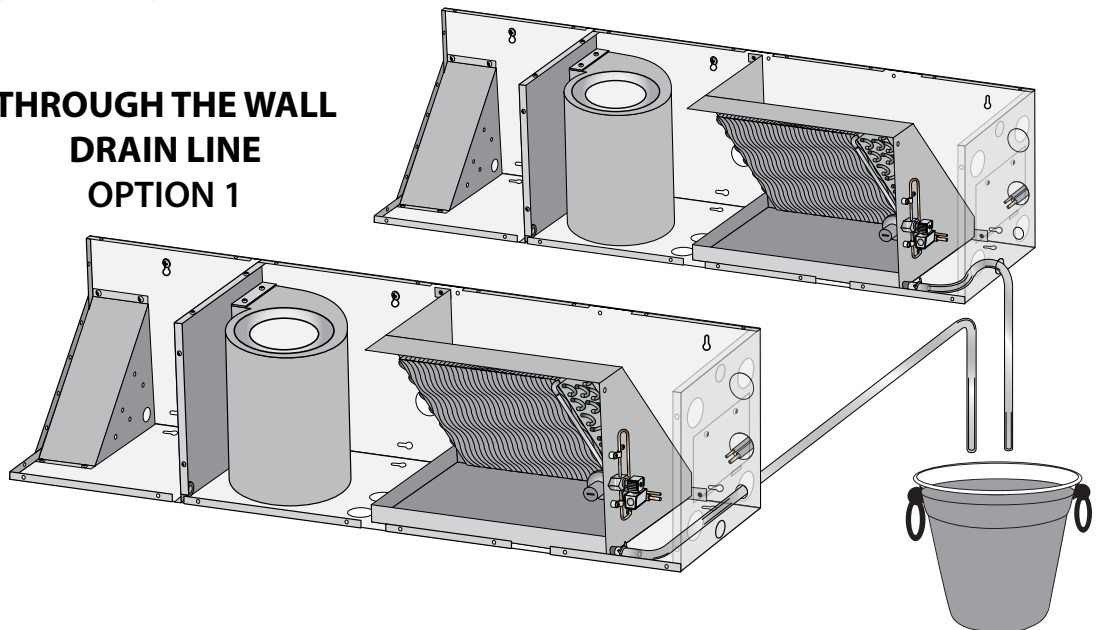

WRONG: Drain line is under water.



Failure to install the drain line voids the warranty.



To prevent mold from growing, allow the drain line to hang above the water line.

FINALIZING HORIZONTAL MOUNT INSTALLATION

Slide the cover of the evaporator unit on. Then screw in 22 #8-18x3/8" Phillips Pan Head screws.

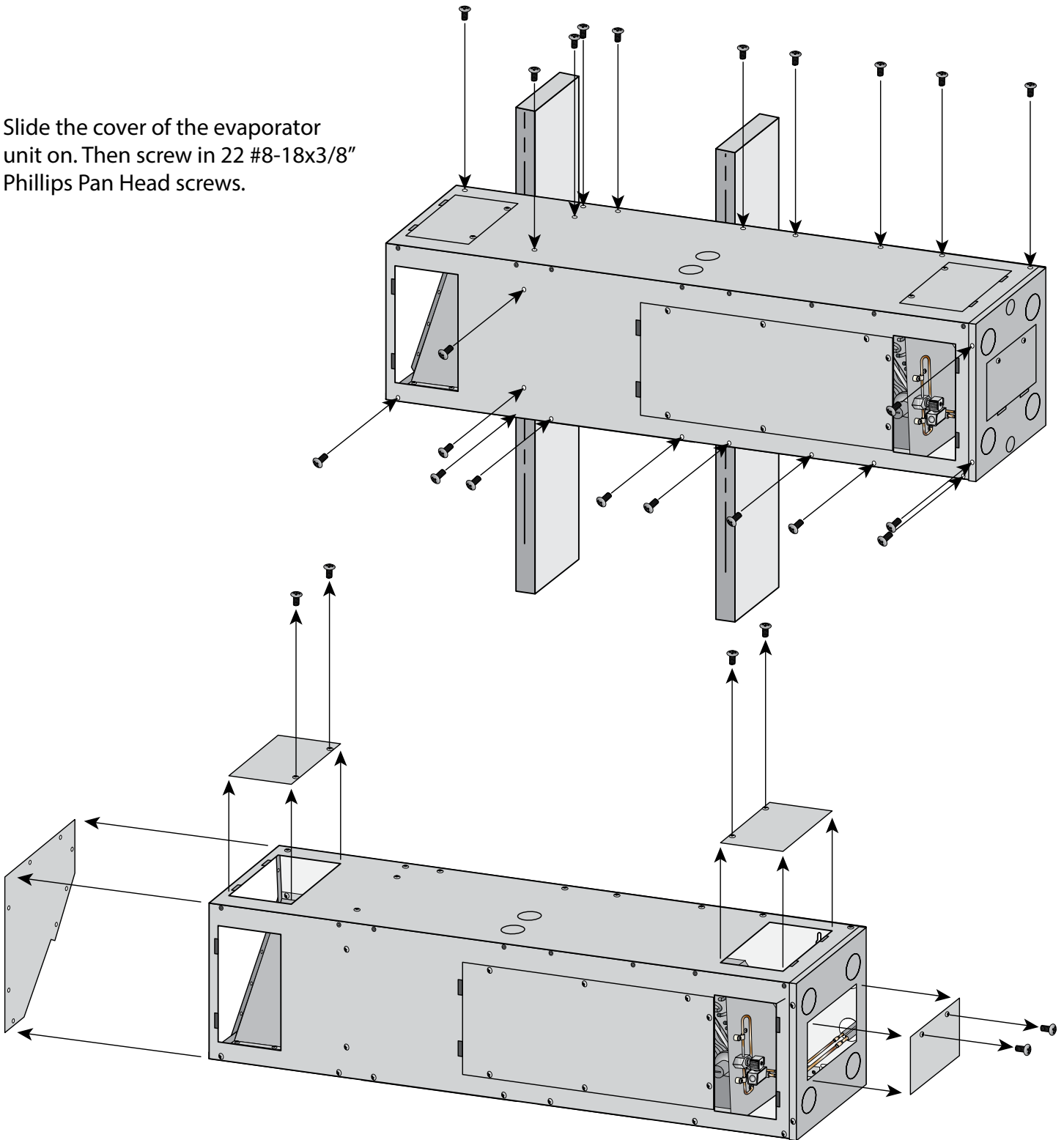

For the 2500 & 3500 models, remove at least one supply and one return panel. For the 5000&6500 models remove at least two return air panels, and at least two supply air panels.

Note: For maximum airflow, remove as many panels as possible.

PREPARING THE INSTALLATION LOCATION

VERTICAL MOUNT

Minimum Tools Needed



5/32" Drill Bit
& Drill



Level

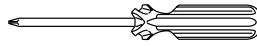

Screwdriver

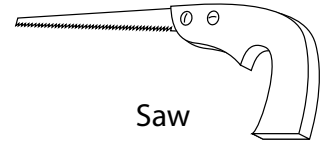

Saw

Locate the desired installation location (no lower than 18" inches from the ceiling). Using a stud finder locate the center of one stud.

Using a level and a pencil, mark a vertical center line down the desired stud. Mark the center line where the screws will be installed.

Locate the desired, line set entry knock out. Measure the hole's relative location with the origin at the center, vertical key hole on the desired mounting side.

Make the same measurement on the wall with the origin at the mark for the center screw. Using a saw, cut out a small square followed by running the line set through the hole.

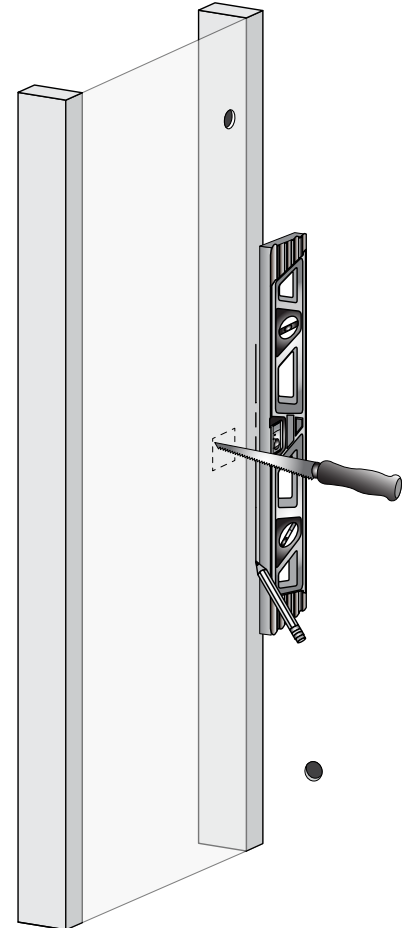

VM Rear

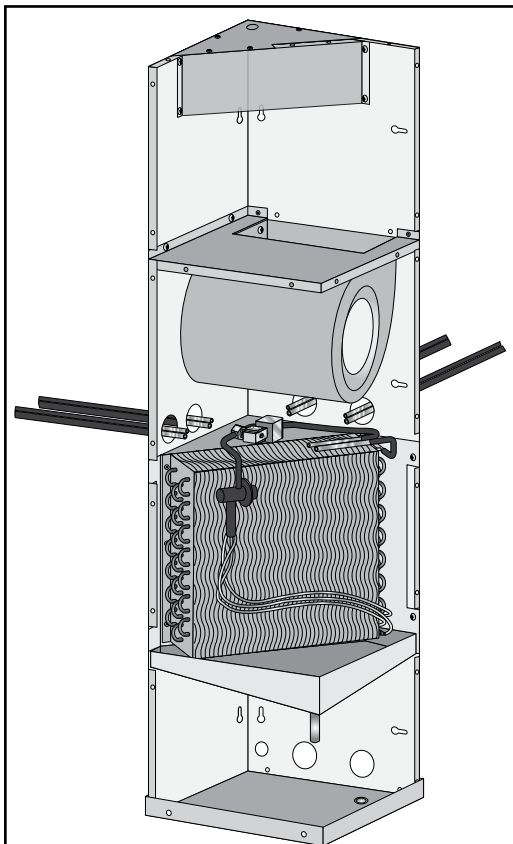

Note: There are six possible knock out holes to use for the line set. Two entries are located on the frontal exterior of the evaporator unit.

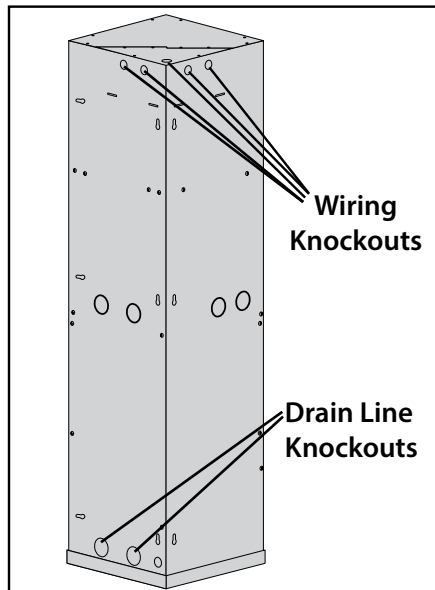

Locate the desired wiring and drain line entry knock outs (see diagram above). Measure the holes' relative location with the origin at the center, vertical key hole on the desired mounting side.

Make the same measurements on the wall with the origin at the mark for the center screw. Using a whole saw, cut out a small 1" diameter whole for the wiring entry followed by running all necessary wires through the whole. If routing the drain line through the wall cut a 1 3/4" diameter whole in desired location.

VERTICAL MOUNT INSTALLATION

Remove 30 #8-18x3/8" Phillips Pan Head screws followed by sliding the cover off of the evaporator unit.

Note: Do not remove the two screws on the rear of the evaporator unit securing the secondary drip tray.

Drill three 5/32" pilot holes in the marks made on the center line. Screw in one of the provided 1 3/4" Hex Head screws in the center hole.

Install the evaporator unit by aligning the center, vertical key hole with the screw on the wall and slide down.

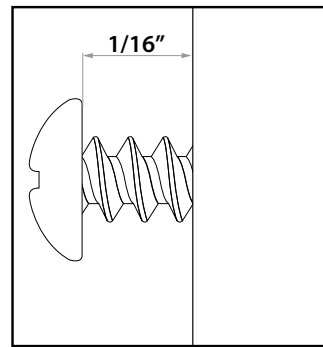
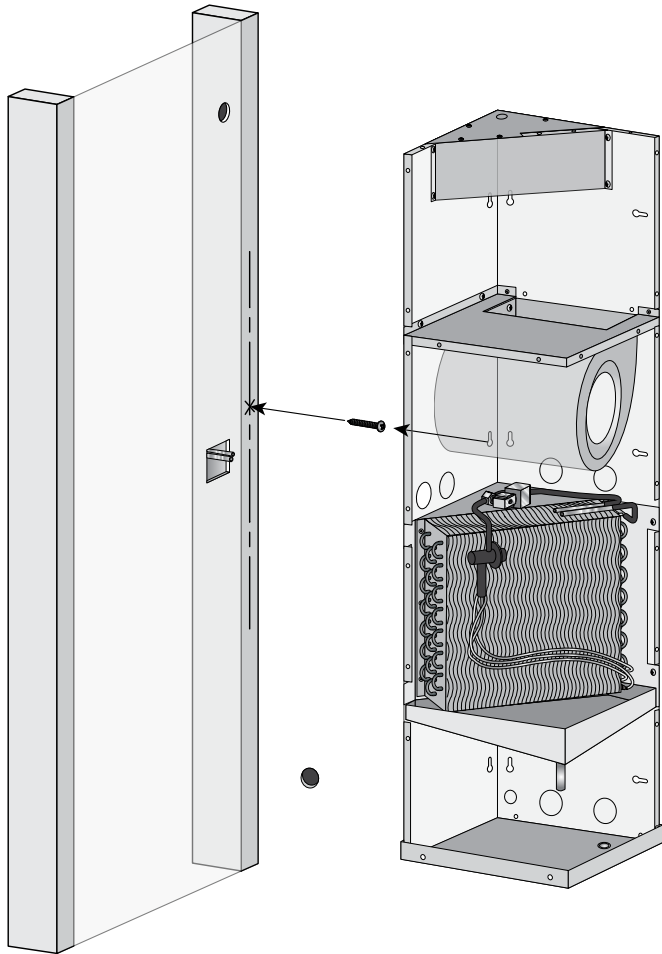
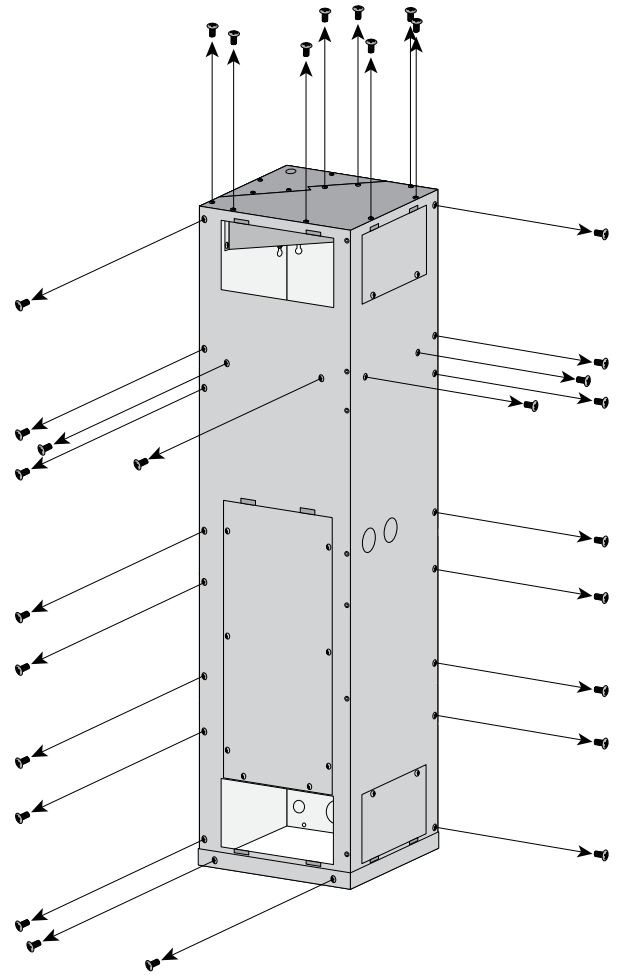

Note: The screws should be installed with about 1/16" between the wall and screw head

VERTICAL MOUNT INSTALLATION

Secure the evaporator unit by installing a screw in both the upper and lower key holes that align with the pilot holes. Tighten all mounting screws once the evaporator unit has been set in place.

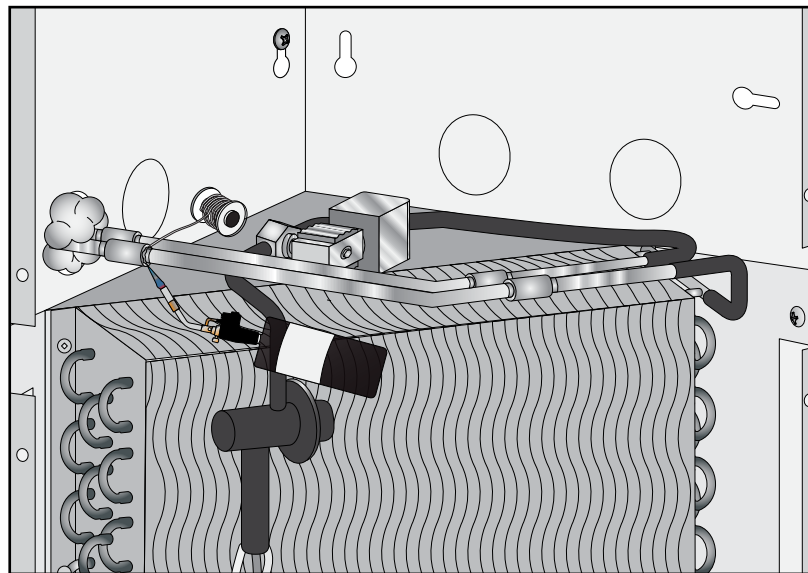
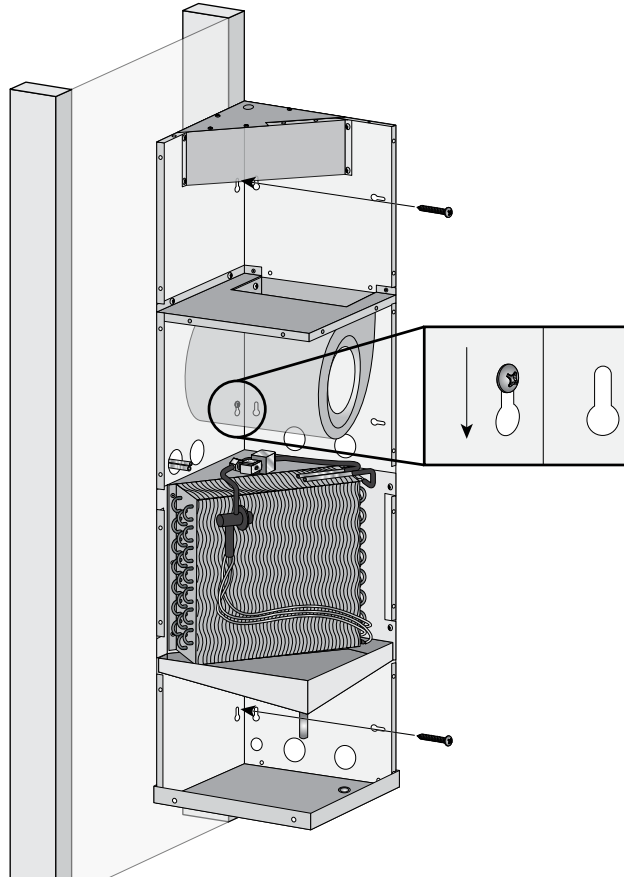

Using proper practices and procedures for brazing refrigeration tubing: Purge nitrogen in to the system, braise the large tube of the line set to the suction line outlet and small tube to the liquid line inlet at the evaporator. Pressurize the system to 200 PSIG for 30 minutes to verify the system is sealed. Once complete, insulate the exposed suction line in the evaporator unit using Armaflex Insulation.

Note: If the liquid line is going to sit in an area with direct sunlight or high ambient temperatures, insulation on the liquid line is recommended. DO NOT INSULATE the suction line and liquid line with direct copper to copper contact. Each line needs to be insulated individually. Seal entry hole using expanding foam insulation.

VERTICAL MOUNT DRAIN LINE

Condensate Drain Line Tube

The condensation drain line tube is used to remove excess condensation from the evaporator unit to a proper discharge location. It is important that the drain line tube is properly connected and used to prevent leakage and other problems associated with excess condensation.

Failure to use the condensate drain line tube will void the warranty on the unit.

Drain Line

All systems come with a drain line for removal of excess condensate. It is mandatory to install the drain line whether it leads through the wall and out of the cellar or remains inside the cellar. During operation, the cooling system will condense excess water from the air in order to maintain the proper level of humidity within the cellar. However in extreme humidity, additional condensate will be removed. Thus the drain line will prevent overflow and leaking by allowing for discharge of the additional condensate.

THROUGH THE WALL DRAIN LINE OPTION 1

Attach the provided tube to the desired drain line option followed by running the line to an appropriate dispense area.

Place hose clamp around the drain line. Slide the drain line over the tube at the outlet of the drip trays. Install the provided hose clamps where the drain line is attached to the tube. This will ensure the tube does not get disconnected.



Failure to install the drain line voids the warranty.



To prevent mold from growing, allow the drain line to hang above the water line.

INSIDE CELLAR DRAIN LINE OPTION 2

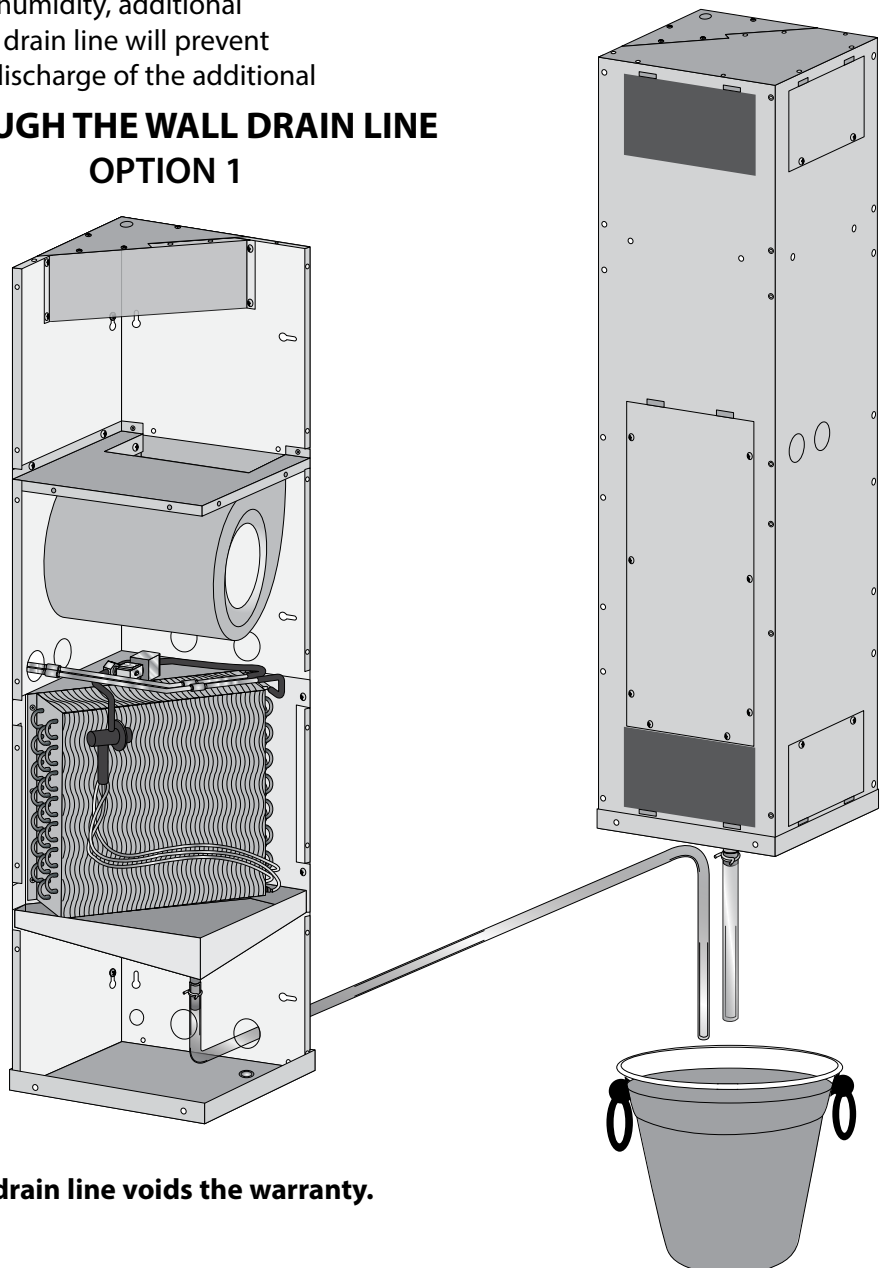

FINALIZING VERTICAL MOUNT INSTALLATION

Slide the cover of the evaporator unit on.
Then screw in 22 #8-18x3/8" Phillips Pan Head screws.

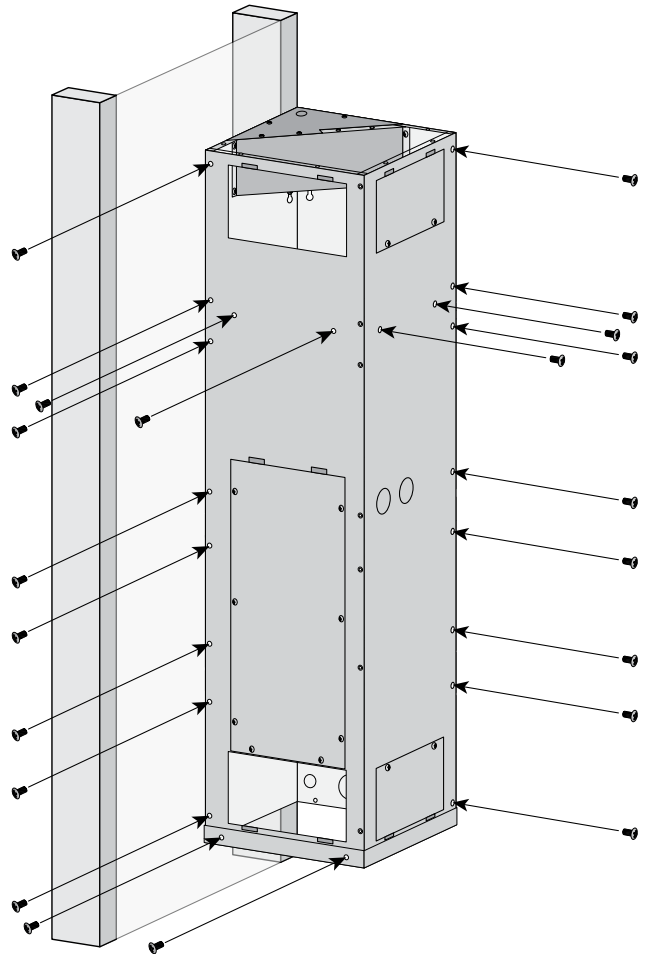
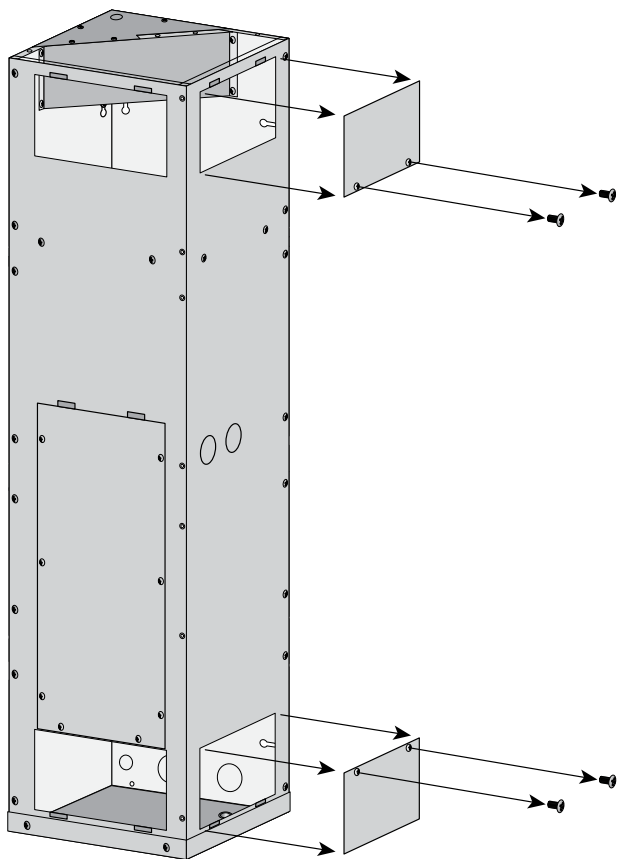

For the 2500 & 3500 models, remove at least one supply and one return panel. For the 5000&6500 models remove at least two return air panels, and at least two supply air panels.

Note: For maximum airflow, remove as many panels as possible.

LIQUID MEASURING THERMOSTAT SYSTEM

The CellarCool Series cooling units come equipped with a liquid temperature measuring thermostat. This incorporates the following advantages:

Self-Calibrating Bottle Probe

The bottle probe contains a sensor chip, which communicates back and forth with the thermostat. This results in a consistent temperature setting and accuracy.

1. Wine should be kept at a very precise, controlled temperature and humidity.
2. By measuring the liquid temperature rather than air, the unit will operate 75–80% of the time.

Setting Up The Bottle Probe:

1. Locate an empty wine bottle.
2. Fill $\frac{3}{4}$ full with room temperature tap water.
3. Place bottle probe securely into bottle as seen in Figure 1.
4. Place bottle with probe level and to the side of the unit in your wine cellar.
5. To assure a consistent temperature, place bottle probe approximately 3 feet away from the air output and not in the flow of the air.

It is recommended that the bottle be placed in a central location of your wine cellar. Avoid pulling too much on the probe cord. It may become disconnected resulting in limited functionality of the unit.

Note: The thermostat can be set between 50–67°F.

Remember: The CellarCool unit operates based on the temperature of the water. Do not be misled by thermostats reading air temperature. The air temperature in the cellar will be cooler than the liquid temperature of the wine while it is reaching optimum balanced temperature.

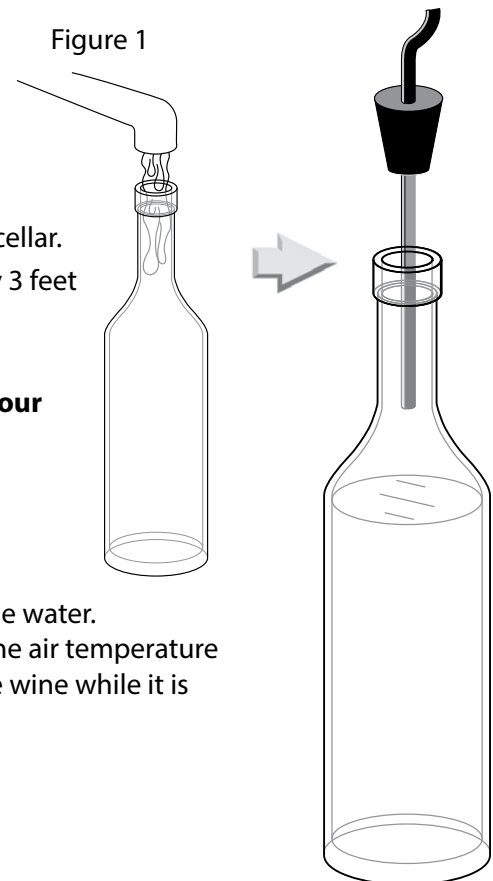

REMOTE KEYPAD: INSTALLATION AND CONFIGURATION

If you have a system with a remote keypad, please review this section for installation.

Note: 50 feet of communication line is included, the keypad can be installed up to 300 line feet away. Longer lengths of communication line can be ordered by calling 1-855-235-5271 ext. 751.

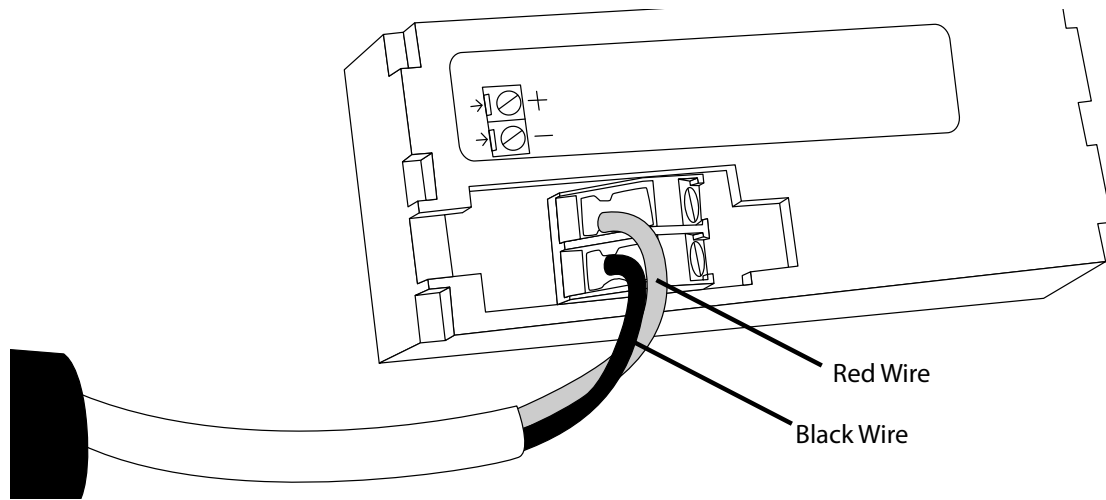

Route the communication line from the evaporator unit to the desired keypad location. Remove the wall mount bracket from the display housing. Using appropriate anchors or fasteners, secure the wall mount bracket to the wall. If routing the communication line through a wall, connect the wires to the back of the control following the image above. Connect the red wire to the upper (+) terminal. Connect the black wire to the lower (-) terminal. If the communication wire is not routed through the wall, remove the plug in the side of the display housing. Route the wire through the hole and connect to the back of the display as shown above.

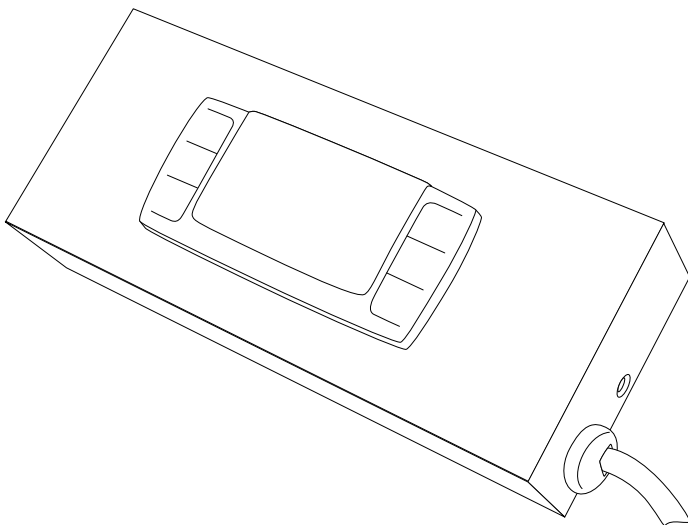



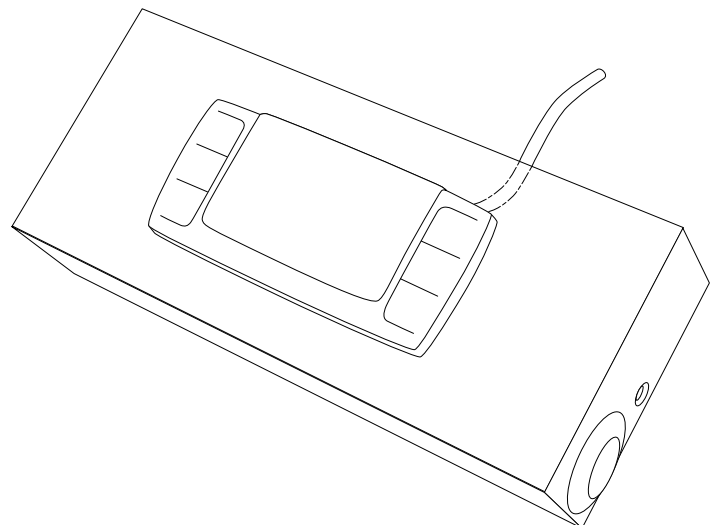



Connection wire in Side Mount configuration

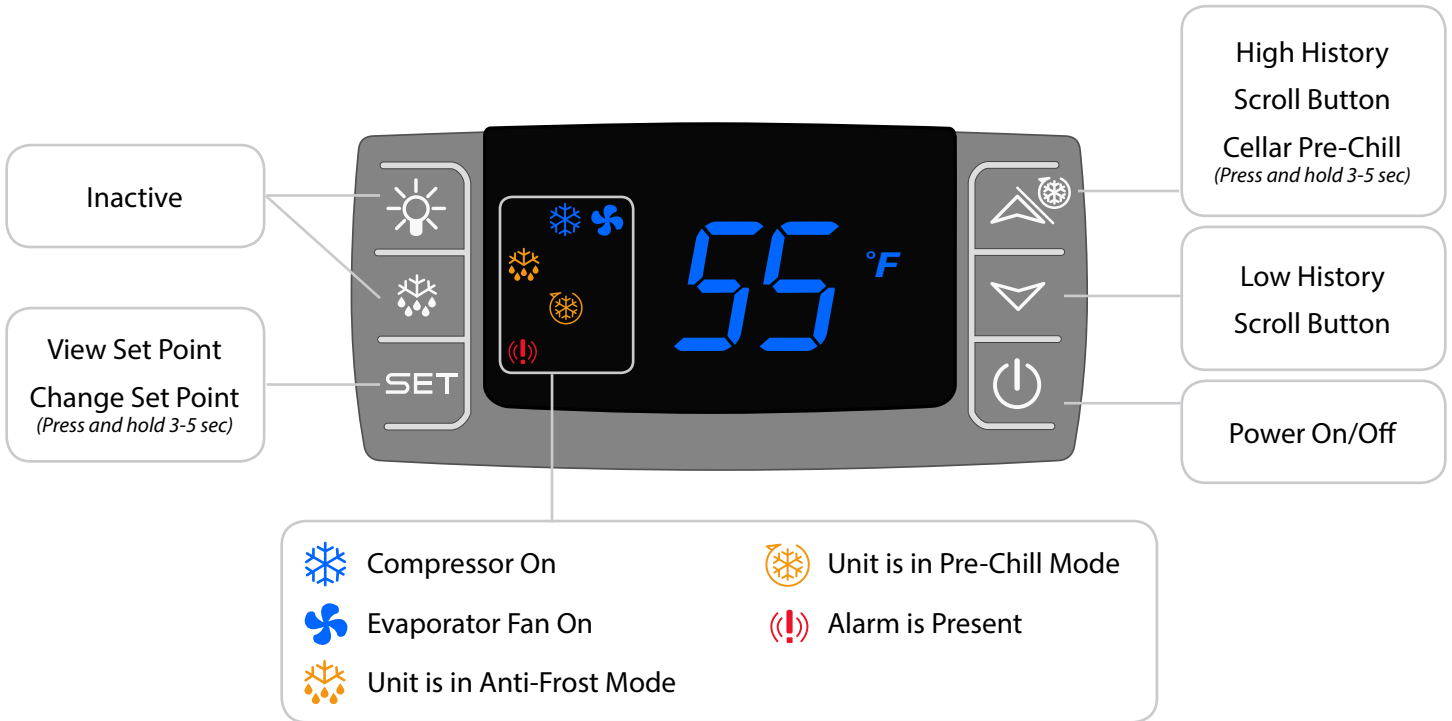



Connection wire in Rear Mount configuration

REMOTE KEYPAD FUNCTIONS



Button	Normal Functions
<p>ON/OFF</p> 	<ul style="list-style-type: none"> The ON/OFF button allows the customer the convenience of turning the refrigeration system ON or OFF, from the Keypad This feature does not disconnect power from the unit. In order for the power to be shut off from the unit, the power cord must be unplugged from the wall receptacle. Press the ON/OFF button once for button application.
<p>Up and Down Arrows</p>  	<ul style="list-style-type: none"> Use these buttons to scroll up or down the CPSM (Customer Preference Selection Mode) menu. Displays the Highest and Lowest temperature sensed by the Air Sensor. This feature allows the customer instant access to the recorded data applicable to the Air Sensor Temperatures, it can be easily reset to reflect current temperatures. <ol style="list-style-type: none"> Press the "UP" arrow, or the "Down" arrow once, and the Highest or Lowest Temperature (Hi/Lo) sensed by the Air Sensor, will be displayed. To reset the Hi/Lo, press and hold the "Set" button when the Hi/Lo value is displayed on the Digital Display, continue to hold the "Set" button until "rst" appears on the digital display and then blinks. This will erase the past recorded "Temperature Data History" and start recording, from the current time and temperature, forward. Temperatures displayed would reflect Air Sensor Temperatures from that point in time, and beyond. The Hi/Lo feature should be reset at initial "Start-Up" and after the Cellar has obtained normal operating temperatures, which is generally 55°F.
<p>Cellar PreChill (CPC)</p>  	<p>The CPC Feature is activated by pressing the Up button for 3-5 seconds, and the CPC logo will be displayed on the digital display. The CPC feature can be terminated by pressing the Up button for 3-5 seconds, or the feature will self terminate after 6 hrs.</p> <ol style="list-style-type: none"> The (CPC) Feature may be used to Pre-Chill the Cellar prior to loading it with Warm Product. The feature will shift the Set Point down to a lower setting of 52°F, for the next 6 hours. After the 6 hour time period, the Set Point will automatically return to the original Set Point. The CPC feature can be conveniently adjusted to the customer's specific needs, by accessing the "Customer Preference Select Mode" (CPSM). See Customer Preference Select Mode Instructions.

<p style="text-align: center;">SET</p>	<p>Set</p> <ol style="list-style-type: none"> 1. Press the "Set" button once and it will display the Set Point. After approximately 5 seconds, the display will return to normal operation and display the Air Sensor temperature. 2. Press the "Set" button once and it will display the Set Point. Press the up and down arrows to change the set point. Press the Set button again and the numbers will blink, confirming the change in Set Point. 3. Press and hold the "Set" button during the display of the Hi/Low "Temperature Data History" (hold button unit "rst" blinks on display), and it will erase the past recorded data file and start recording, from the current time and temperature. 4. Press the "Set" and the "Down Arrow" buttons simultaneously, for 3-5 seconds, and you will access the "Customer Preference Selection Mode" (CPSM). The CPSM allows the customer to "Fine Tune" the Control Operating System to their applicable choice.
<p style="text-align: center;">Alarm</p> 	<p>The Alarm symbol is shown when the unit encounters an issue that needs attention, the displayed alarm codes are explained below.</p>
<p style="text-align: center;">Anti-Frost</p>  <p style="text-align: center;">AUX</p>	<p>The Anti-Frost Cycle is automatically activated when the evaporator temp has reached a low temp of 26° and has sustained that temp for a period of five minutes. During this cycle the compressor and condenser fans will turn off and the evaporator fans will continue to run. Once the temperature of the evaporator gets back up to 40° the cycle will deactivate and the unit will revert back to normal operating conditions. This cycle can only be activated once an hour.</p> <p>At the beginning of the cycle the AUX symbol will be illuminated and the  symbol is illuminated during the anti-frost cycle.</p>

Alarm Codes

Message	Cause	Solution
"P1"	Faulty Bottle Probe Connection	1. Check Bottle Probe connection at green terminal block on controller.
	Defective Bottle Probe	Replace the Bottle probe
"P2"	Faulty Evaporator Probe Connection	Check Evaporator Probe connection at green terminal block on controller
	Defective Evaporator Probe	Replace the Evaporator Probe
"HA"	Defective Bottle Probe	Replace the Bottle Probe
"LA"	The Bottle probe is sensing a temperature of 10° below the set point	Allow the room to warm up which will increase the temperature of the wine
	Defective Bottle probe	Replace the Bottle probe
"POF"	The keypad is locked	Hold "Up" and "Down" buttons for 3 to 5 seconds to disable, "PON" should appear

<p>CPSM Mode</p>	<p>Press the “Set” and the “Down Arrow” buttons simultaneously, for 3-5 seconds, and you will access the “Customer Preference Selection Mode” (CPSM). The CPSM allows the customer to “Fine Tune” the Control Operating System to their applicable choice.</p> <p>The following CPSM options are available for adjustment:</p> <p>Fon – Humidity Management Enhancement: This parameter is normally set at 0, which should provide adequate relative humidity for the cellar.</p> <ul style="list-style-type: none"> • An increase in this parameter will increase the Humidity Enhancement (%RH), and a decrease in the parameter will decrease Humidity Enhancement (%RH). • Adjustments should be made in increments of 5, with a maximum of 15, and a minimum of 0. • After any adjustment to Humidity Enhancement, you should wait a minimum of three days before making any additional adjustments. This will allow the cellar sufficient time to acclimate to the new setting. <p>Fof - Humidity Management Enhancement: This parameter is normally set at 15. This parameter should not be adjusted, as it simply provides an OFF cycle time for the fan, during the compressor OFF cycle. However, the parameter is located within the CPSM as a convenience to the customer, should it need to be adjusted. CCT - Cellar Pre-Chill Duration: This parameter is set to 6 hours, but can be changed between 0-23.5 hours.</p> <p>Con/Cof – Compressor On time (Con) and Off time (Cof) with a Probe 1 failure/ Alarm. These parameters are set at Con 40 min/Cof 10 min. In the event that there is a Probe 1 failure/Alarm, the compressor/refrigeration system automatically starts a predetermined ON/OFF cycle, which is controlled by the Con and the Cof parameters. The customer can adjust these parameters to maintain the desired Bottle temperature.</p>
-------------------------	--

SYSTEM OPERATION WITH CELLARCOOL CONTROLLER

Initial Start-Up:

When power is applied to the unit, the control will briefly display all symbols, and the Snowflake Symbol will be displayed (if unit is calling for cooling) fan symbol is displayed and the fan symbol will be displayed. There may be a brief delay prior to the evaporator fan turning on.

Set Point:

The set point is set from the factory (CellarCool) at 55°. It can be adjusted by the customer between 50° and 70° in one degree increments.

Cooling Operation:

Cooling is activated once the Air Probe senses a temperature that is 4° greater than the set point. The controller then energizes the Solenoid Coil which activates the Solenoid Valve(s). The unit provides cooling until the Air Probe senses the set point. At this point the Solenoid Coil is de-energized, suction pressure drops below 5 psig and the Low Pressure Switch kills power to the compressor. If the FON function is enabled the evaporator fan will continue to run for 1-15 minutes to re-evaporate any moisture from the evaporator coil.

Humidity Features:

The FON parameter can be increased to allow the evaporator fan to run for a longer period of time after the compressor turns off, allowing moisture to be re-evaporated into the cellar.

Anti Short Cycle

The Anti Short Cycle ensures that the unit will remain off for a period of 5 minutes after the unit has reached the set point to allow the pressure in the refrigeration system to equalize prior to starting the compressor.

Anti Frost Cycle

The Anti Frost Cycle is a precautionary measure, as icing or frosting of the coil does not occur during normal operation. The system will go through a defrost cycle every 4 hours. During the defrost cycle, the indoor fan will provide air flow across the indoor coil, which will evaporate any frost accumulation.

Low Ambient Conditions

If the condensing unit is installed outside (which will allow the condenser to be exposed to low ambient temperatures), the condenser fan may cycle on and off. The purpose of the fan cycling is to maintain the system high side pressure, which will ensure an adequate refrigeration process.

Bottle Probe Failure Protection

In the event that a Bottle probe should fail, the APST (Advance Product Safety Technology) will automatically transition the Refrigeration cycle to a pre-determined time series (based on detailed laboratory testing), which will ensure that the product is kept within the safe range.

Remote Control Panel Keypad

The remote keypad is designed to give the user the ability to monitor and change cellar conditions.

HM2500C / VM2500C EVAPORATOR WIRING DIAGRAM WITHOUT CELLARCOOL CONTROLLER

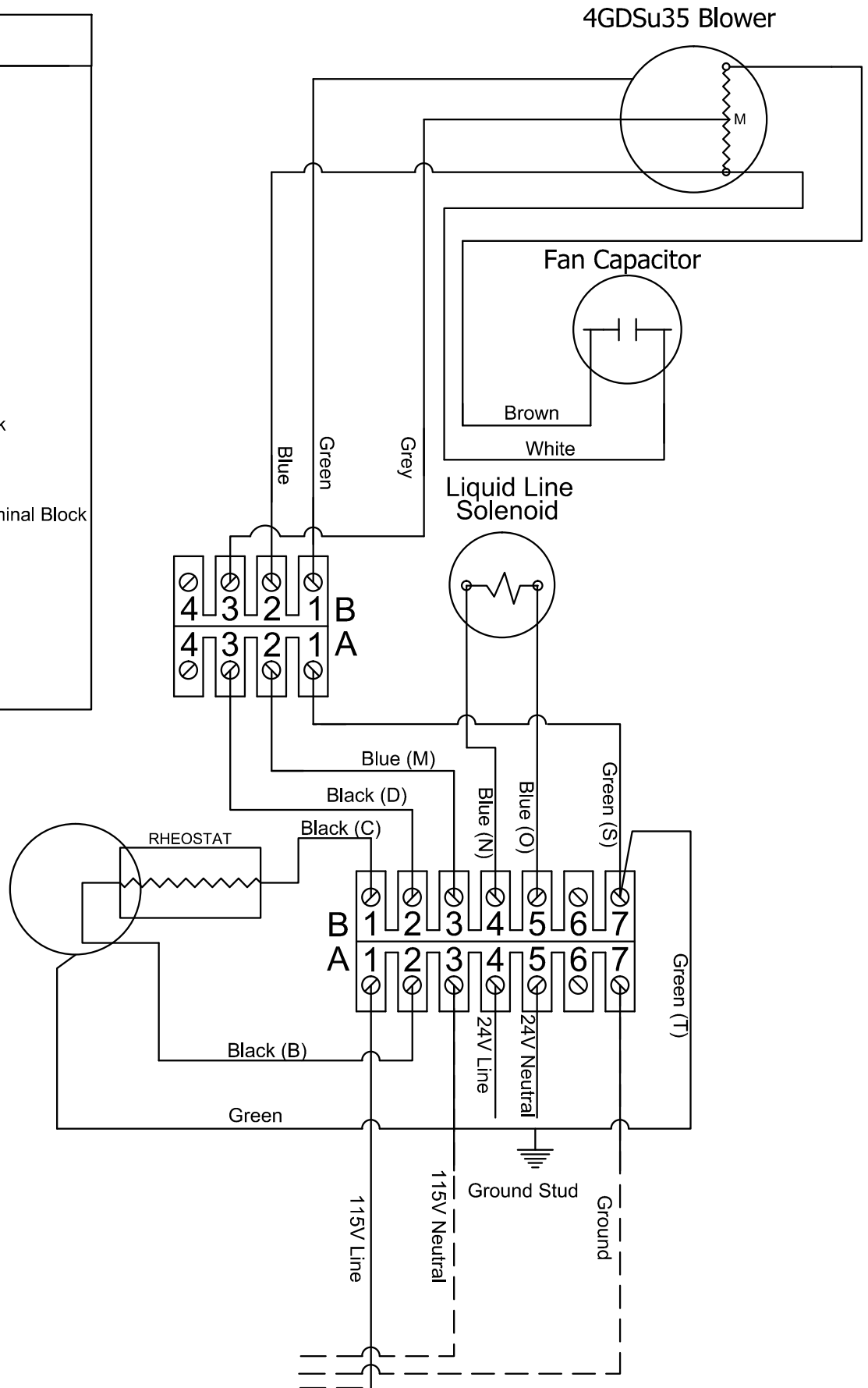
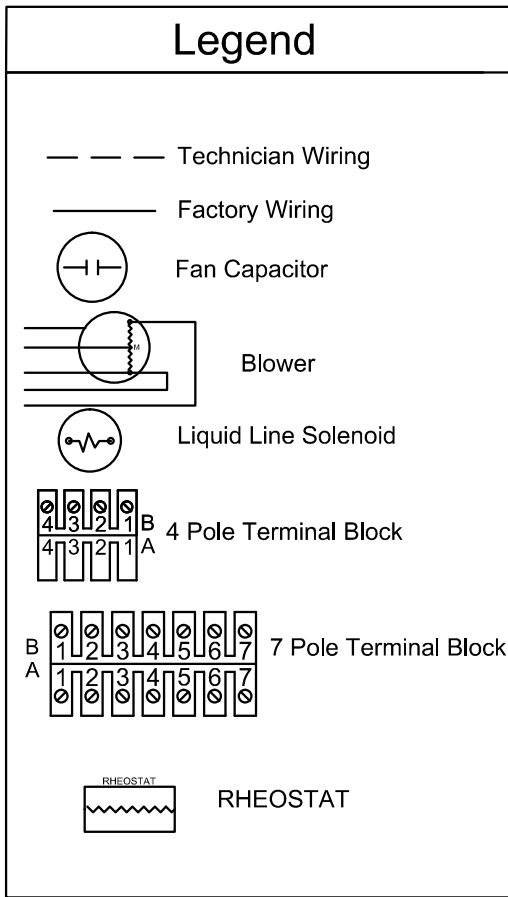

HM2500CR / VM2500CR EVAPORATOR WIRING DIAGRAM WITH CELLARCOOL CONTROLLER

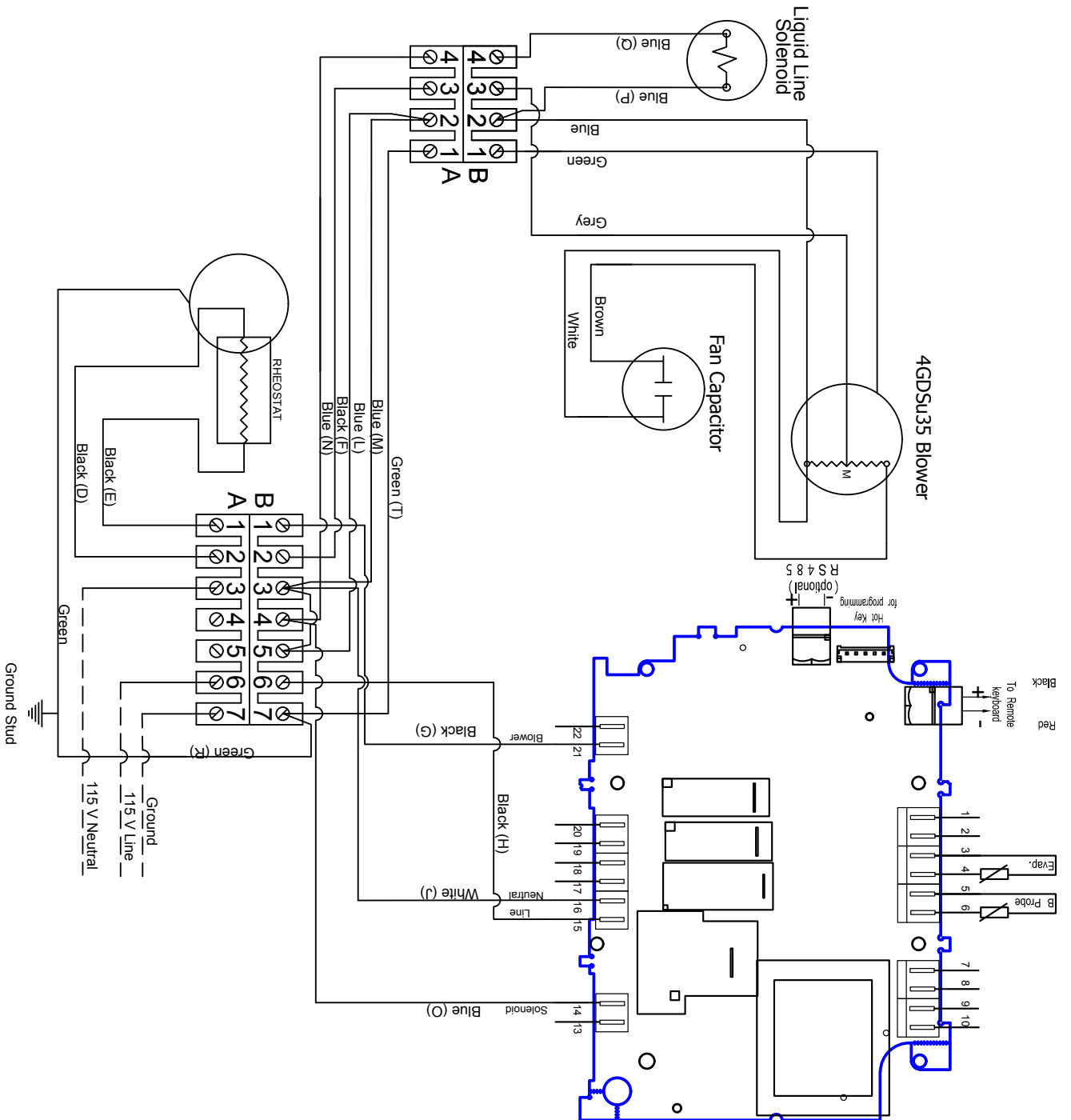
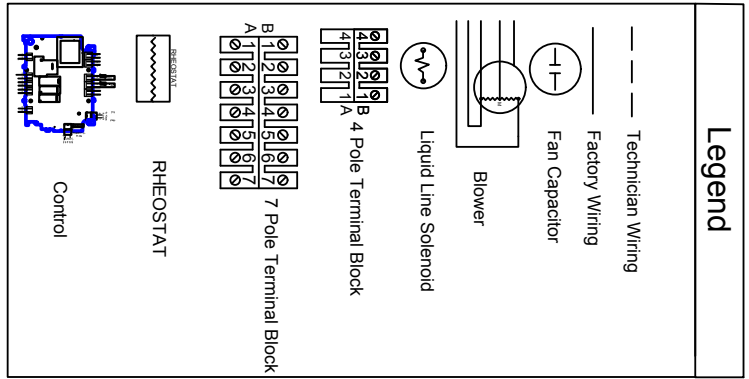

HM2500C / VM2500C EVAPORATOR WIRING DIAGRAM WITH 24V HOME THERMOSTAT

Legend

- Technician Wiring
- Factory Wiring
- Fan Capacitor
- Blower
- Liquid Line Solenoid
- 4 Pole Terminal Block
- 7 Pole Terminal Block
- RHEOSTAT
- Blower Relay
- Transformer
- 24v T-STAT

TRANSFORMER & THERMOSTAT
INSTALLED BY TECHNICIAN

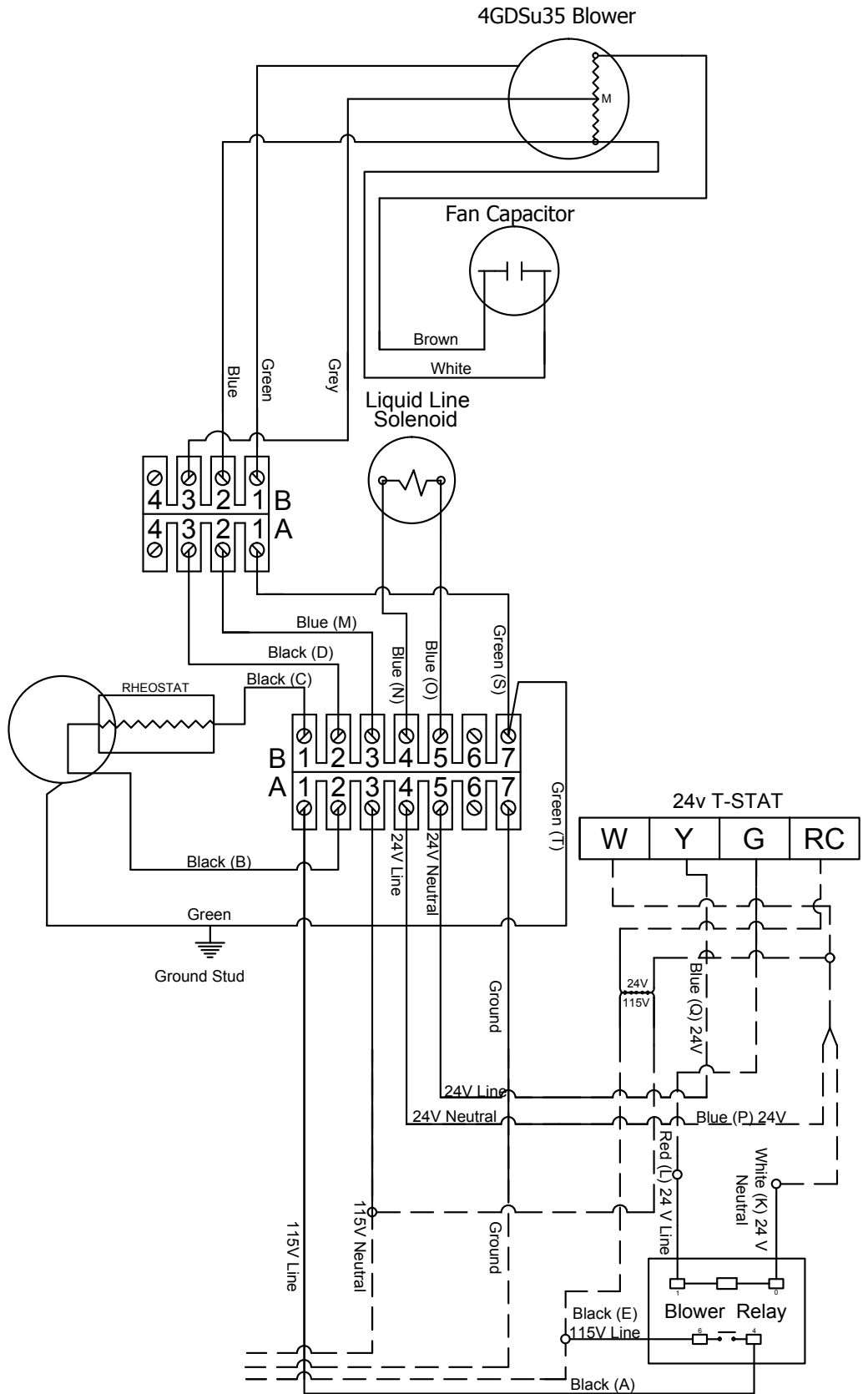

HM2500 / VM2500 CONDENSER WIRING SCHEMATIC

LEGEND:
TERMINAL BOARD

BD #	SERVES	COLOR
1	GROUND	GREEN UK GREEN/YELLOW STRIPE
2	L1-115V-HOT	BLACK
3	115V-NEUTRAL	RED UK-CAN WHITE
4	CC HEATER	BLACK
5	COMP GND	GREEN
6	H-COMP	BLACK
7	N-COMP	WHITE
8	H-COND FAN	BLACK
9	LINE H-LP-HP	BLACK
10	LOAD H-LP-HP	BLUE

TD=TIME DELAY, DELAY ON BREAK

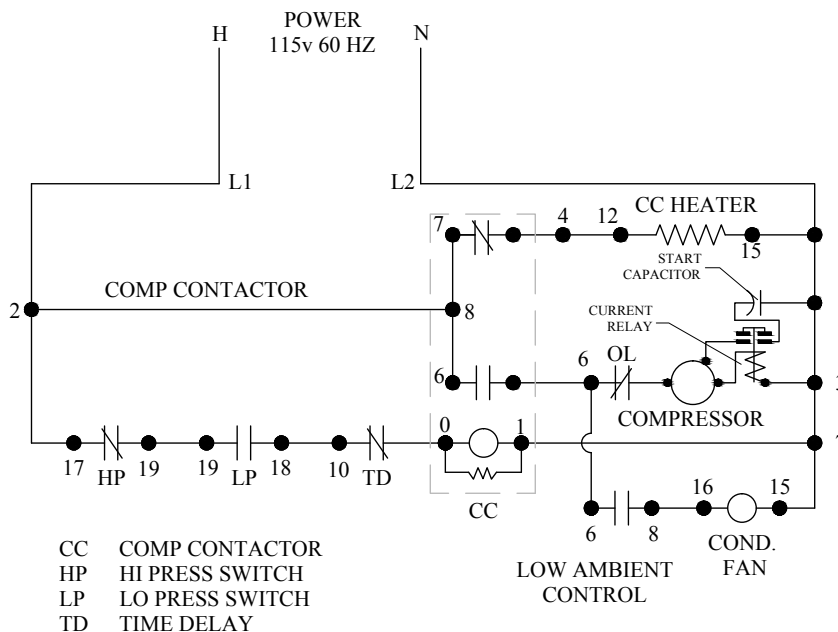
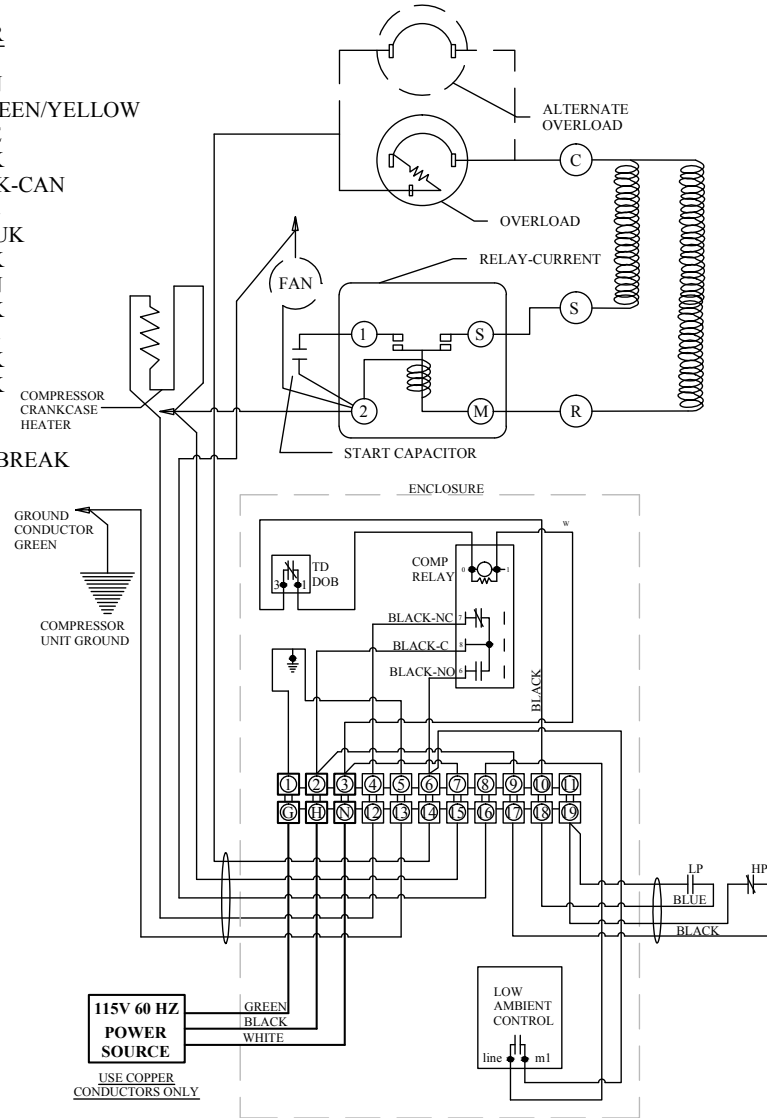

CC COMP CONTACTOR
HP HI PRESS SWITCH
LP LO PRESS SWITCH
TD TIME DELAY

HM3500C / VM3500C EVAPORATOR WIRING DIAGRAM WITHOUT CELLARCOOL CONTROLLER

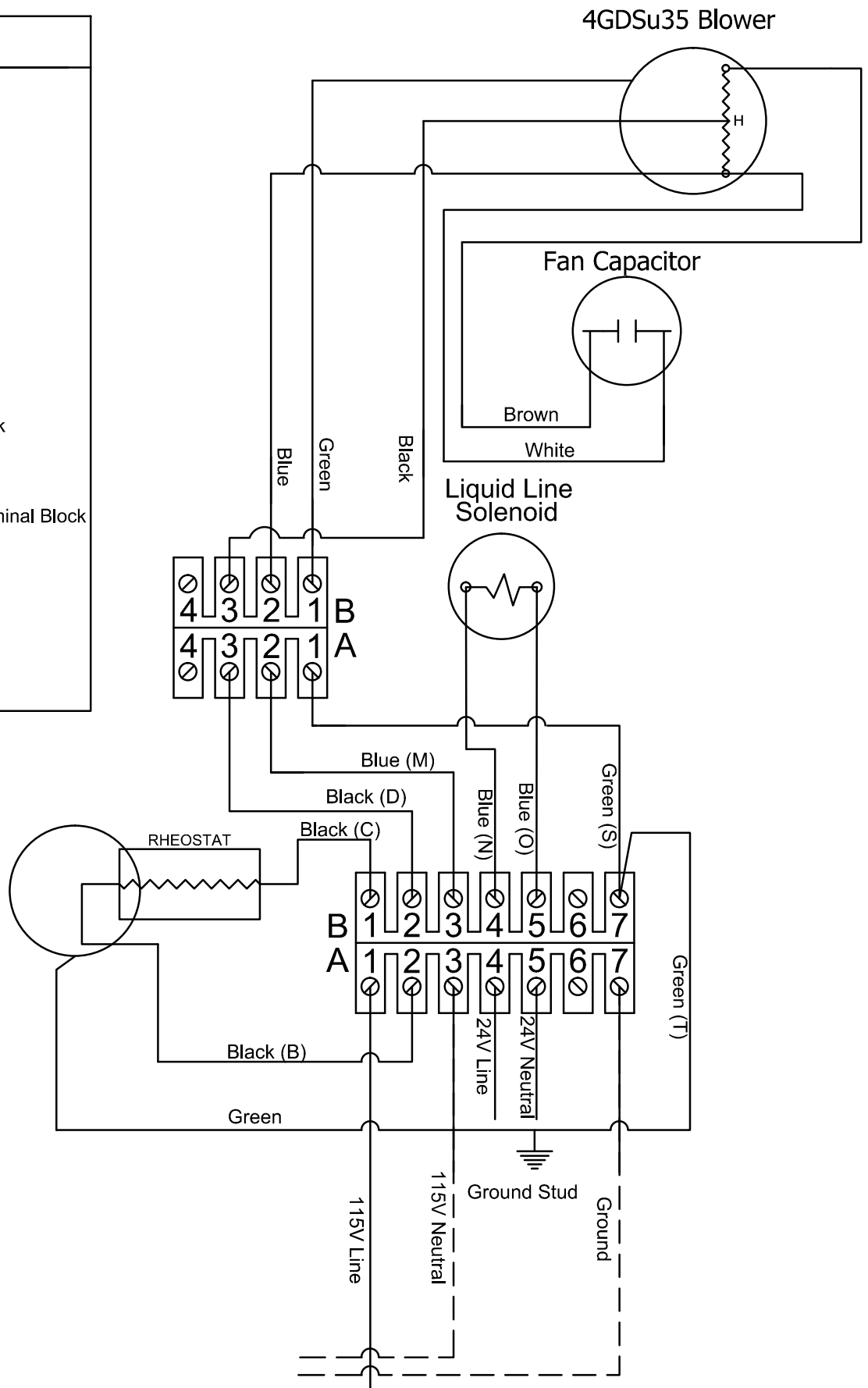
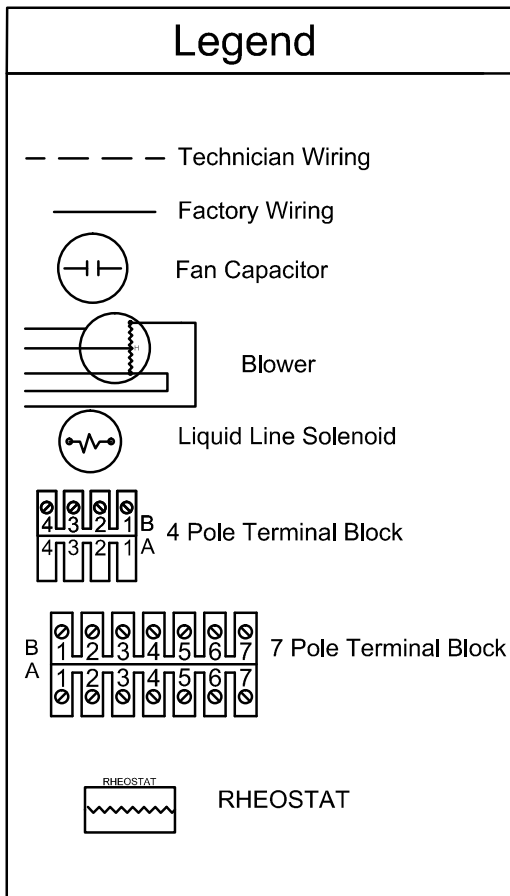

HM3500CR / VM3500CR EVAPORATOR WIRING DIAGRAM WITH CELLARCOOL CONTROLLER

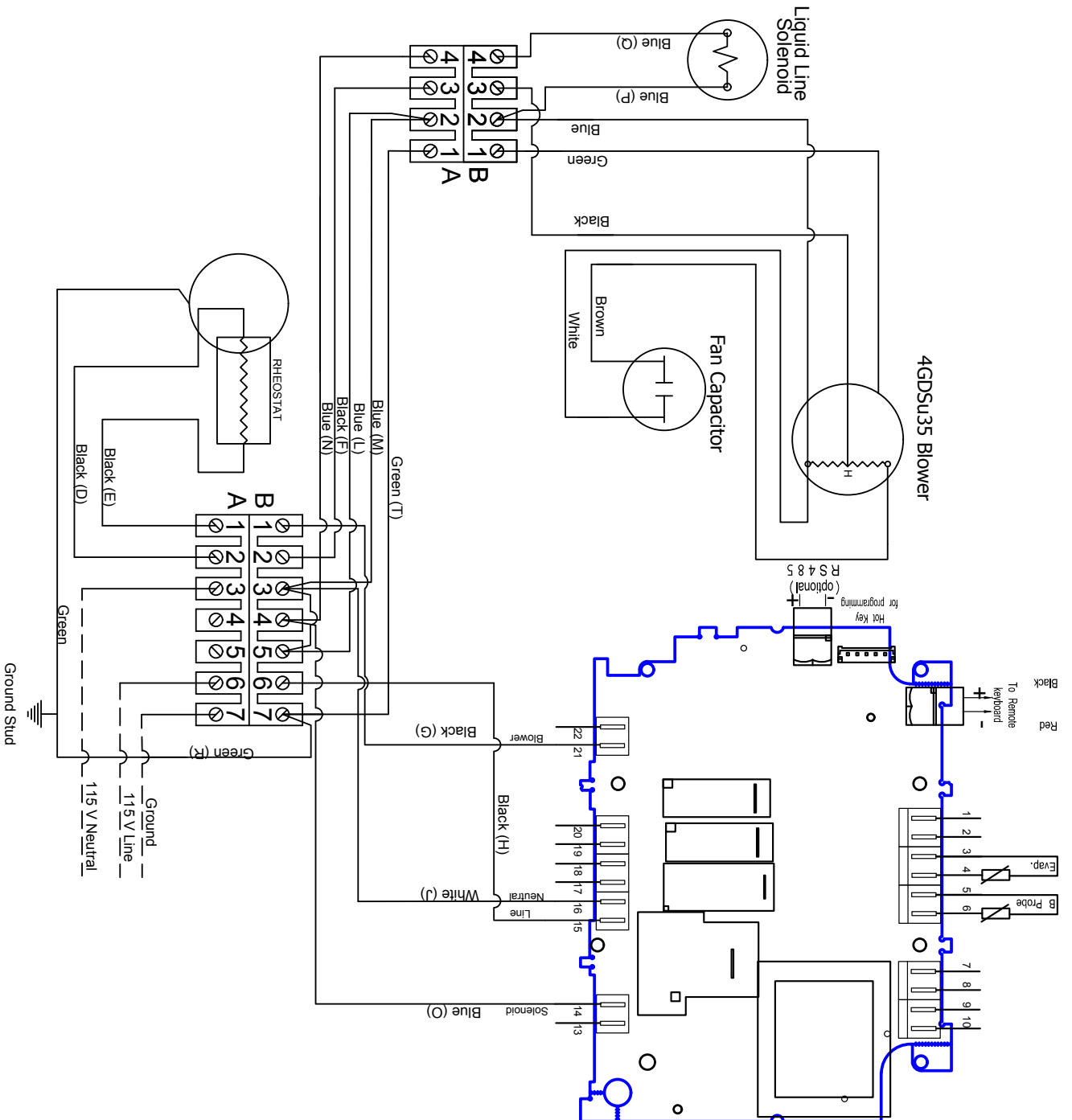
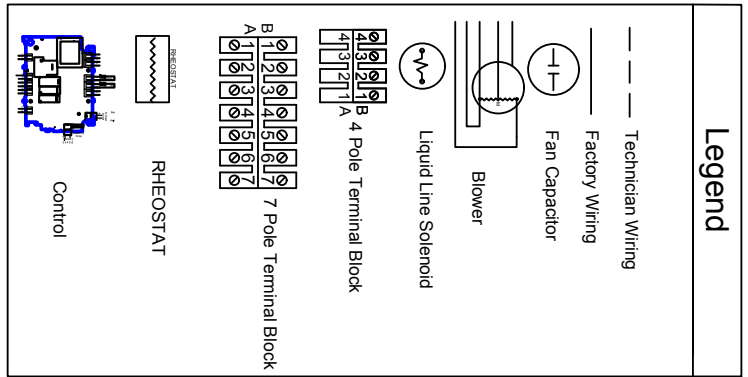

HM3500C / VM3500C EVAPORATOR WIRING DIAGRAM WITH 24V THERMOSTAT

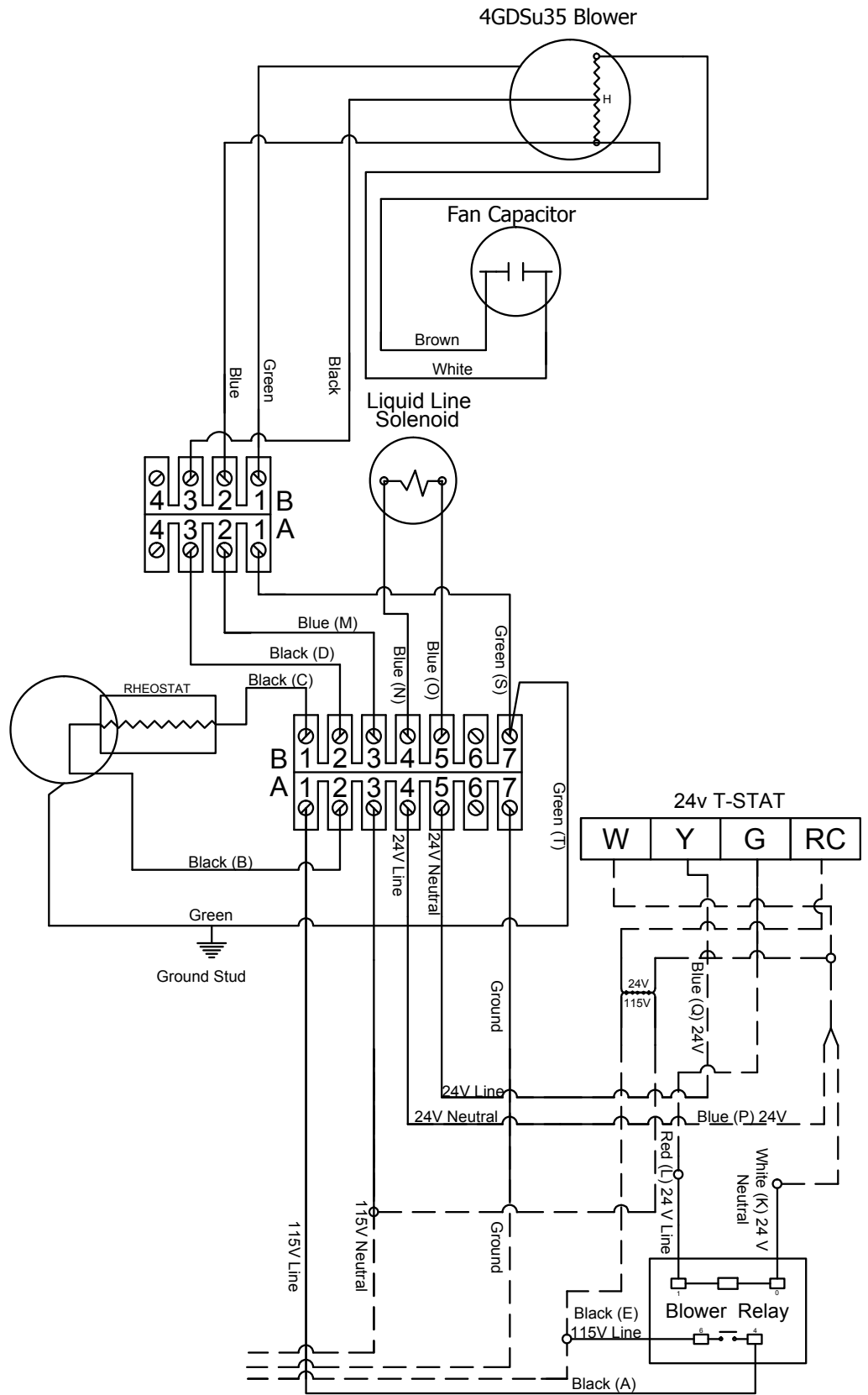
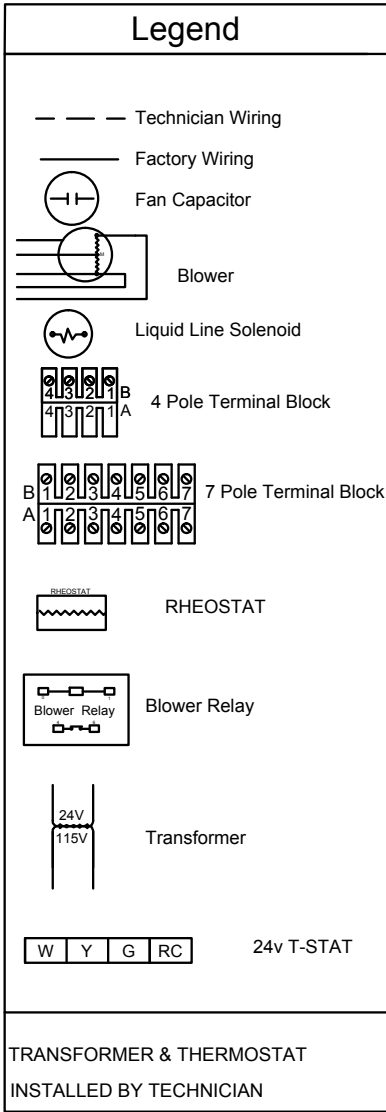

HM3500 / VM3500 CONDENSER WIRING SCHEMATIC

**LEGEND:
TERMINAL BOARD**

BD #	SERVES	COLOR
1	GROUND	GREEN UK GREEN/YELLOW STRIPE
2	L1-115V-HOT	BLACK RED UK-CAN
3	115V-NEUTRAL	WHITE BLUE UK
4	CC HEATER	BLACK
5	COMP GND	GREEN
6	H-COMP	BLACK
7	N-COMP	WHITE
8	H-COND FAN	BLACK
9	LINE H-LP-HP	BLACK
10	LOAD H-LP-HP	BLUE

TD=TIME DELAY, DELAY ON BREAK

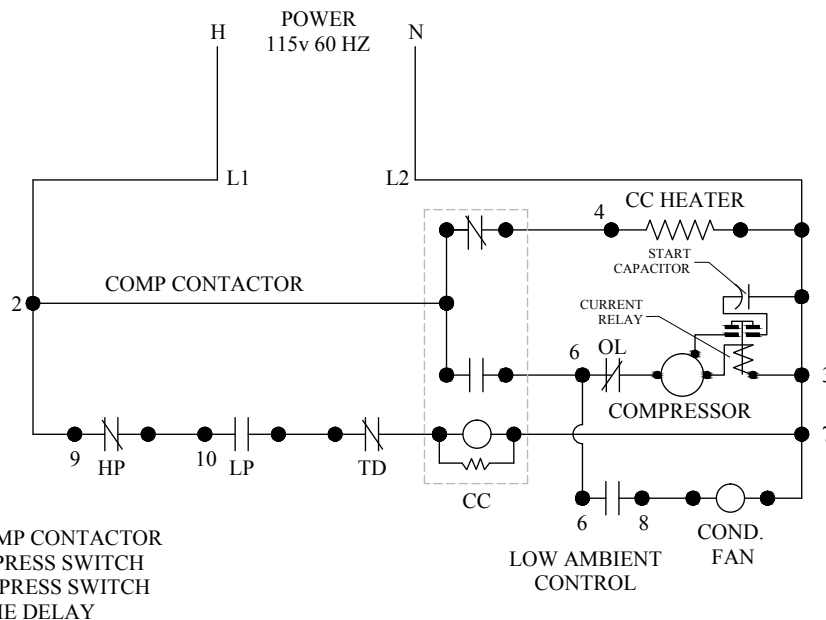
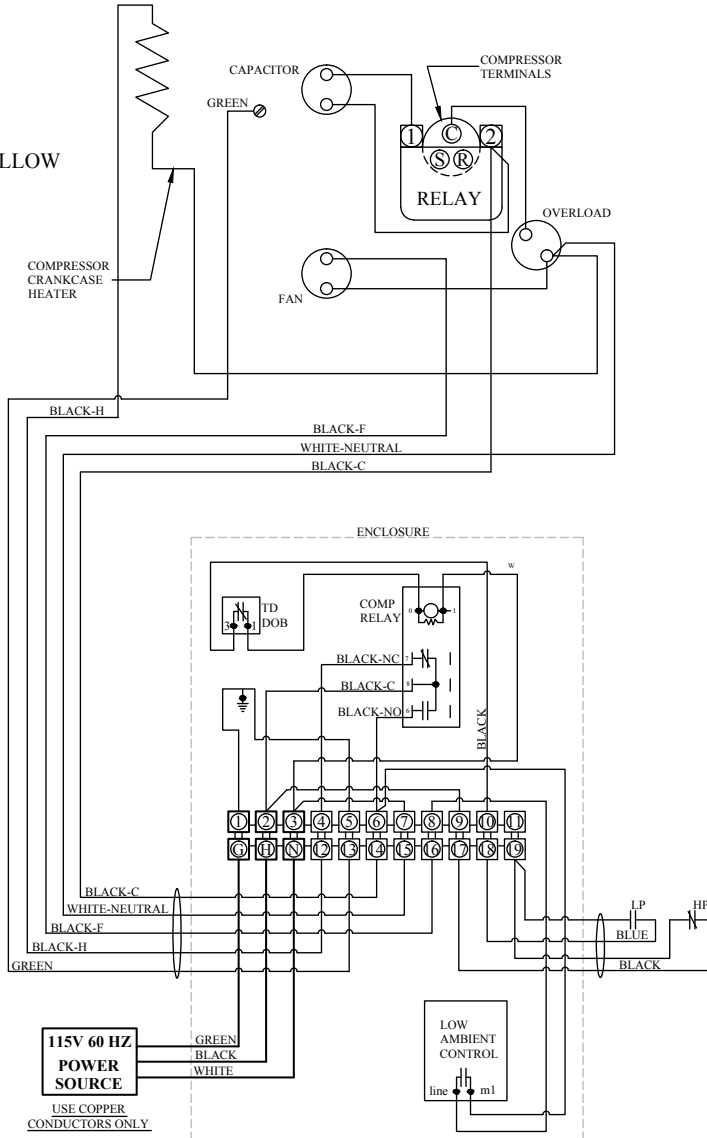

- CC COMP CONTACTOR
- HP HI PRESS SWITCH
- LP LO PRESS SWITCH
- TD TIME DELAY

HM500C / VM500C / HM6500C / VM6500C EVAPORATOR WIRING DIAGRAM WITHOUT CELLARCOOL CONTROLLER

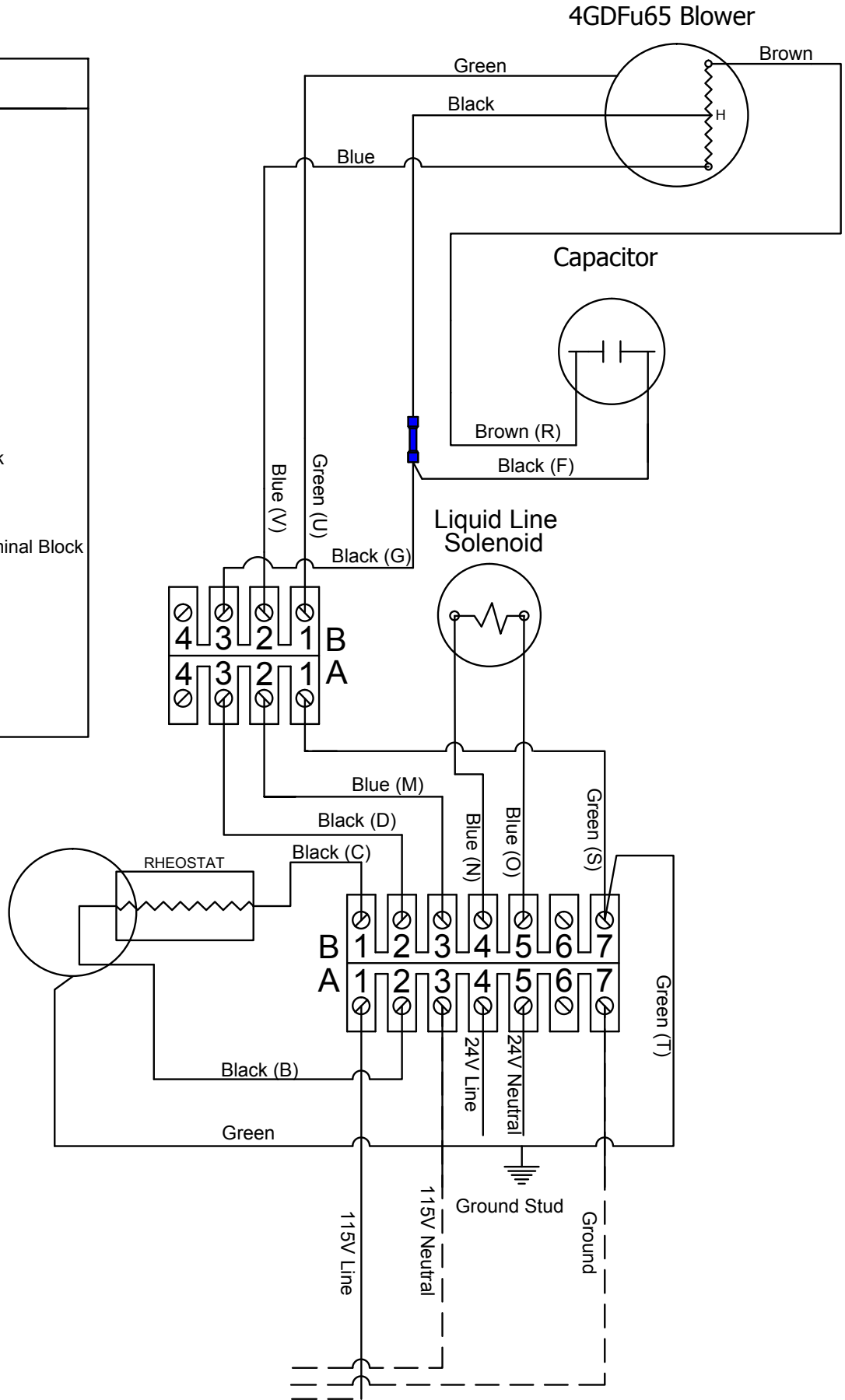
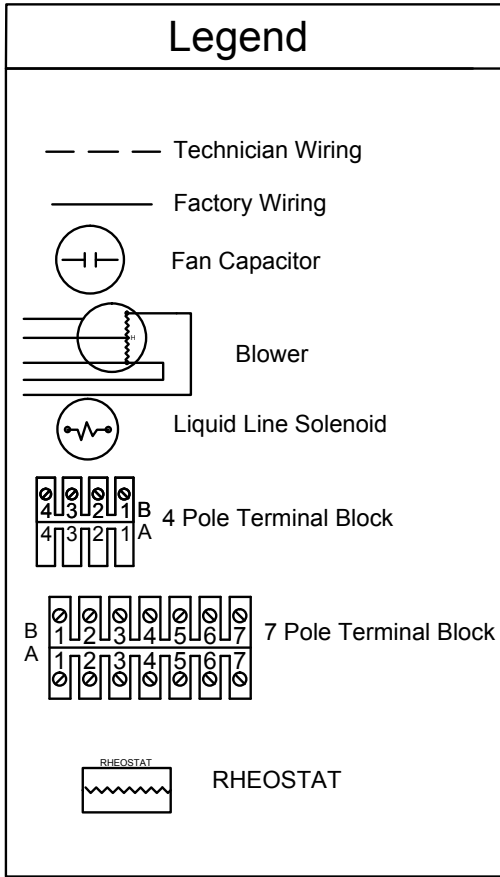

HM500C / VM500C / HM6500C / VM6500C EVAPORATOR WIRING DIAGRAM WITH CELLARCOOL CONTROLLER

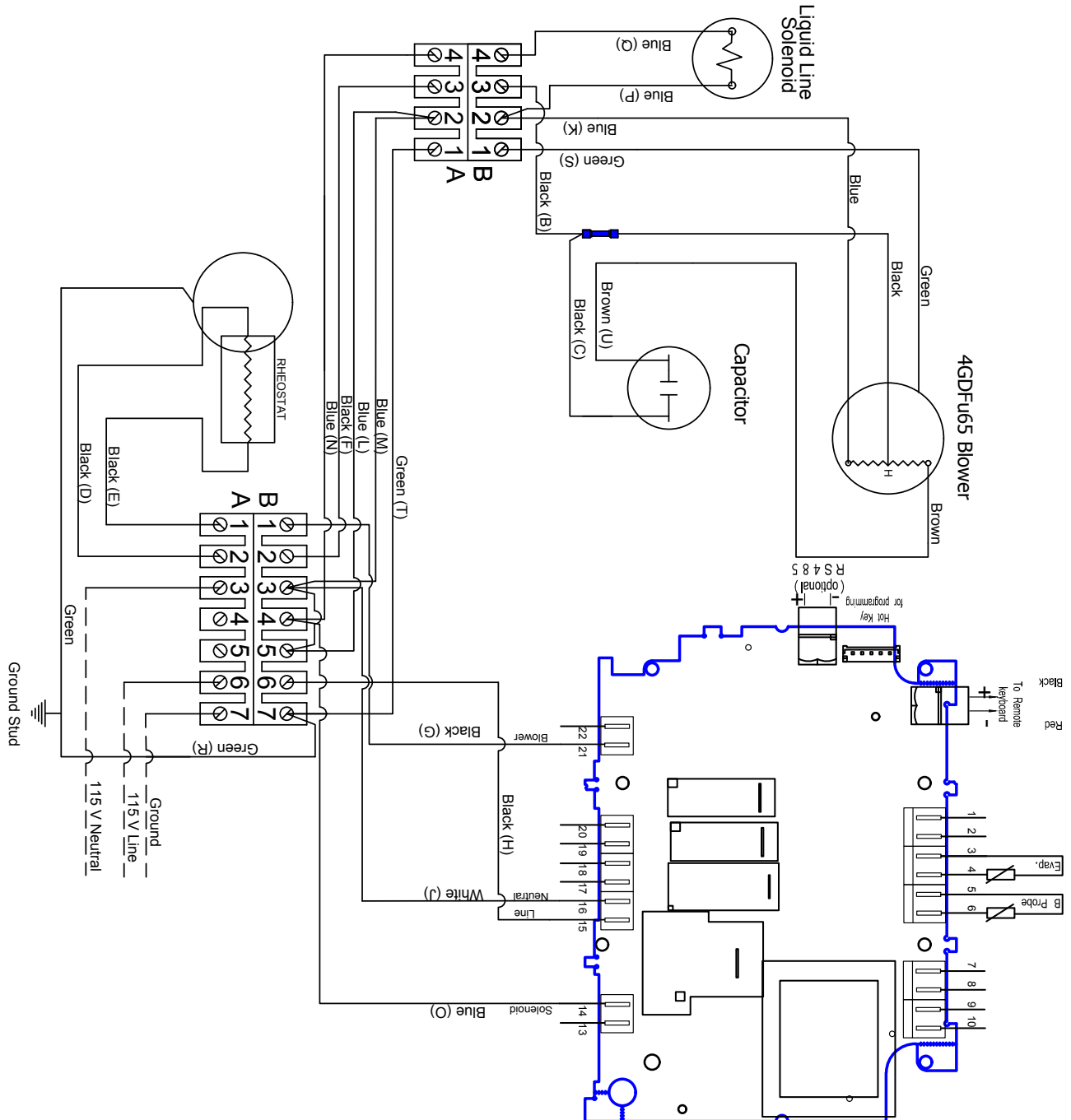
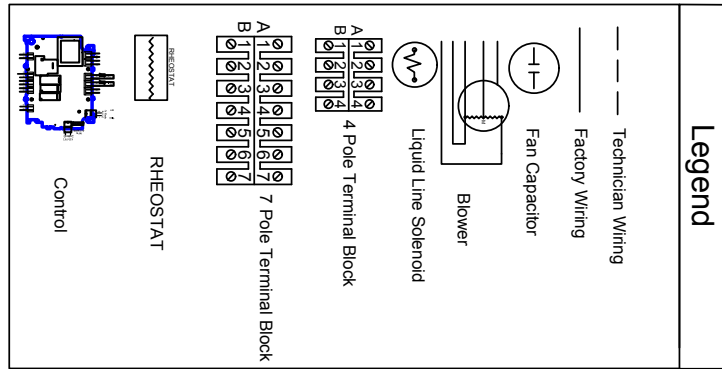

HM5000 / VM5000 / HM6500 / VM6500 EVAPORATOR WIRING DIAGRAM WITH 24V THERMOSTAT

Legend

- Technician Wiring
- Factory Wiring
- Fan Capacitor
- Blower
- Liquid Line Solenoid
- 4 Pole Terminal Block
- 7 Pole Terminal Block
- RHEOSTAT
- Blower Relay
- Transformer
- 24v T-STAT

TRANSFORMER & THERMOSTAT
INSTALLED BY TECHNICIAN

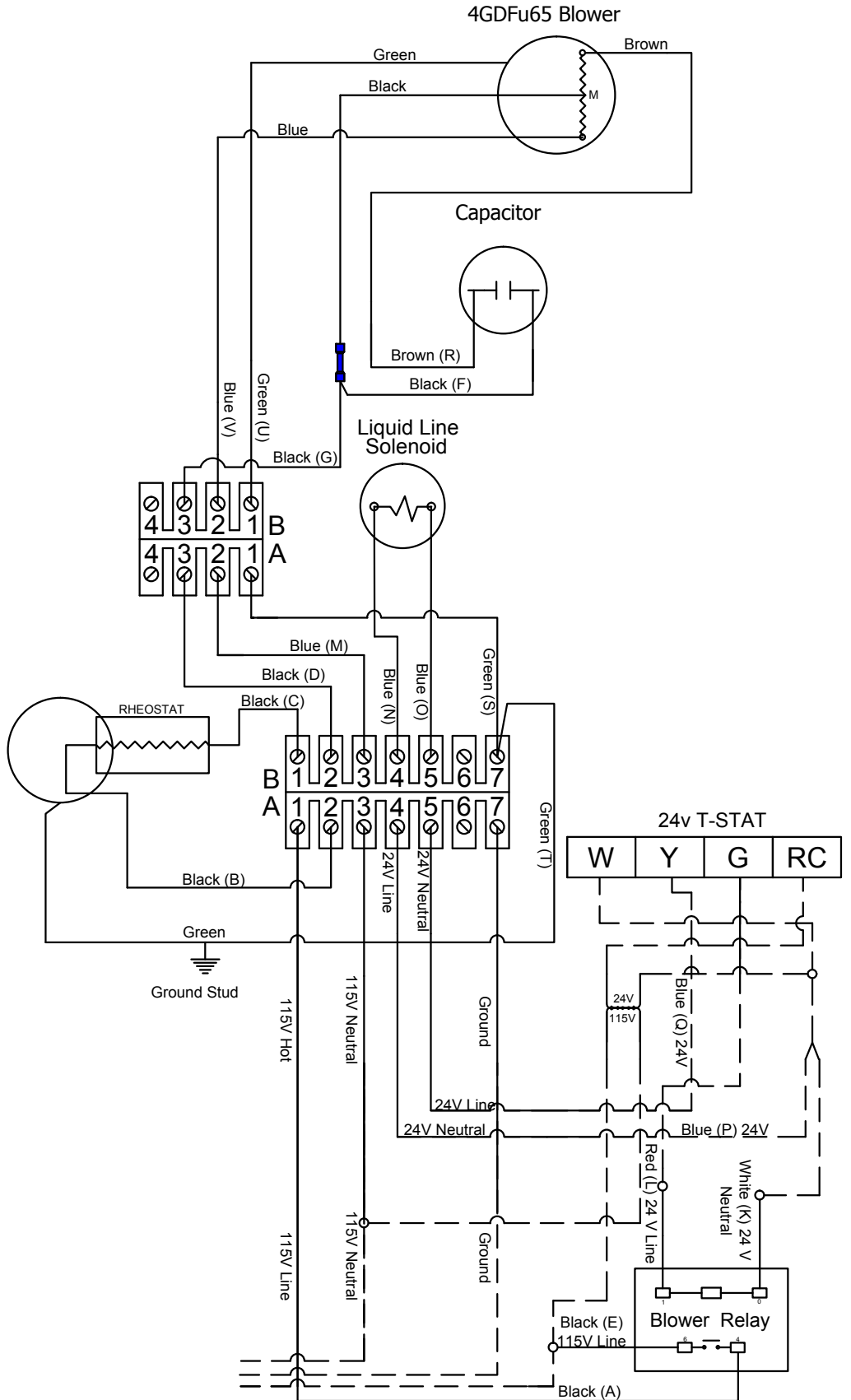

HM5000 / VM5000 CONDENSING WIRING SCHEMATIC

LEGEND:
TERMINAL BOARD

BD #	SERVES	COLOR
1	GROUND	GREEN UK GREEN/YELLOW STRIPE
2	L1-115V-HOT	BLACK RED UK-CAN
3	115V-NEUTRAL	WHITE BLUE UK
4	CC HEATER	BLACK
5	COMP GND	GREEN
6	H-COMP	BLACK
7	N-COMP	WHITE
8	H-COND FAN	BLACK
9	LINE H-LP-HP	BLACK
10	LOAD H-LP-HP	BLUE

TD=TIME DELAY, DELAY ON BREAK

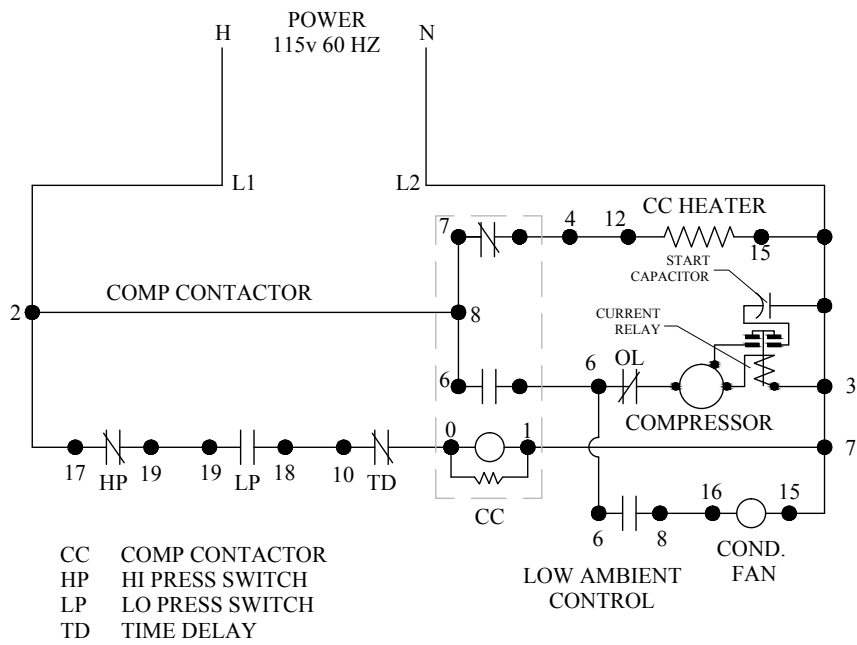
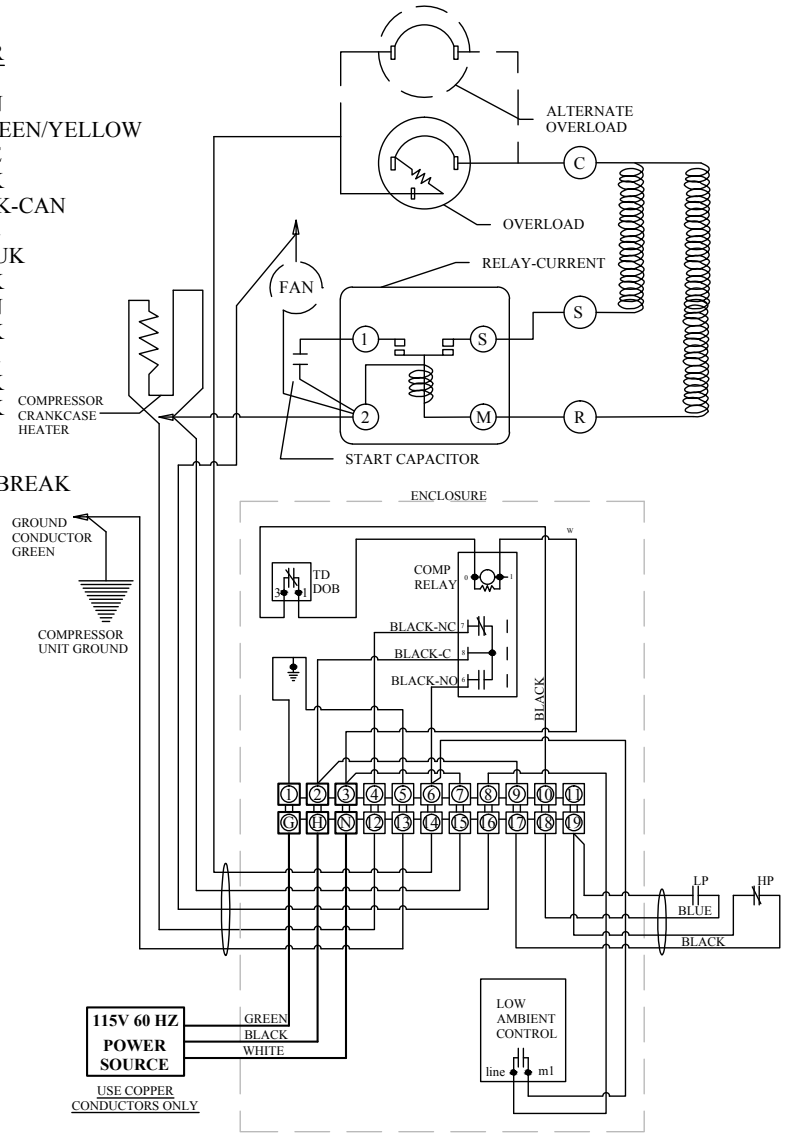

CC COMP CONTACTOR
HP HI PRESS SWITCH
LP LO PRESS SWITCH
TD TIME DELAY

HM6500 / VM6500 CONDENSING WIRING SCHEMATIC

LEGEND:
TERMINAL BOARD

BD #	SERVES	COLOR
1	GROUND	GREEN UK GREEN/YELLOW STRIPE
2	L1-115V-HOT	BLACK RED UK-CAN
3	115V-NEUTRAL	WHITE BLUE UK
4	CC HEATER	BLACK
5	COMP GND	GREEN
6	H-COMP	BLACK
7	N-COMP	WHITE
8	H-COND FAN	BLACK
9	LINE H-LP-HP	BLACK
10	LOAD H-LP-HP	BLUE

TD=TIME DELAY, DELAY ON BREAK

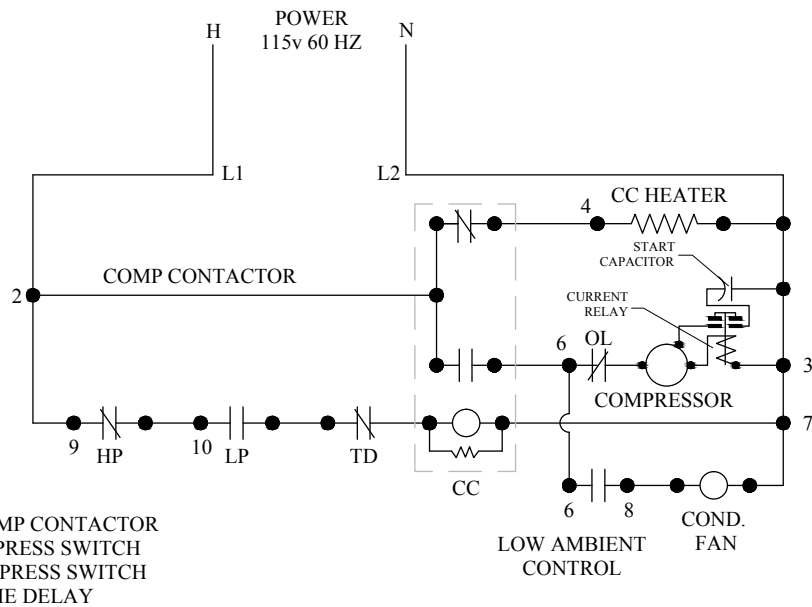
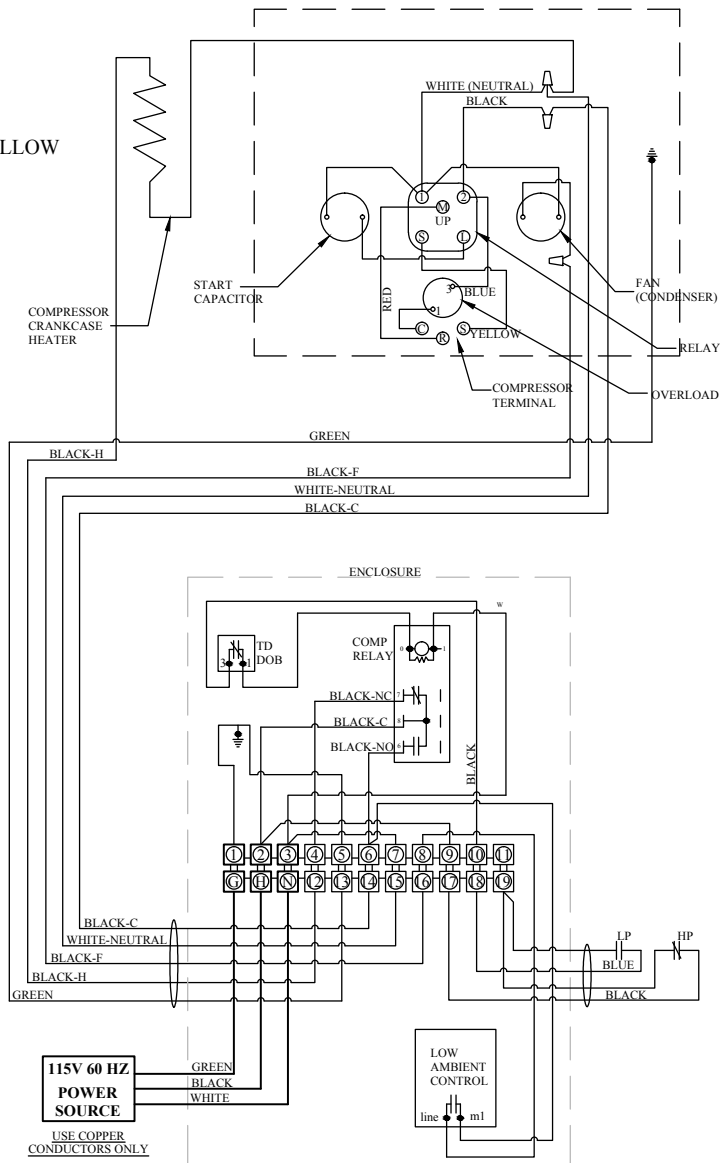

CC COMP CONTACTOR
HP HI PRESS SWITCH
LP LO PRESS SWITCH
TD TIME DELAY

LOW AMBIENT CONTROL
COND. FAN

MAINTENANCE SCHEDULE

Monthly	<ol style="list-style-type: none">1. Check coils2. Check for unusual noise or vibration3. Check the drain line to see if it is above the waterline if draining into a vessel.
Quarterly	<ol style="list-style-type: none">1. Use a vacuum with brush attachment to clean coils. Be careful not to crush coil fins when cleaning.
Annually	<ol style="list-style-type: none">1. Inspect for corrosion.2. Check wiring connections and integrity of cords.3. Pour a 50/50 bleach solution into the drain line every spring.

TROUBLESHOOTING GUIDE

Unit has ice forming on the evaporator	
Possible Cause	Solution
Evaporator coil is dirty.	Clean coil with a vacuum. If coil is very dirty, use a spray bottle with a small amount of liquid dish washing detergent. Spray coil, let set for 5 min, then flush with fresh water.
There is something blocking the supply and/or return air	Remove blockage
The evaporator fan is not turning on.	Call a service tech to troubleshoot
The evaporator unit has not gone through its anti-frost sequence, yet.	Check for ice in the depth of the coil. Melt with blow drier until coil is warm to the touch. Soak up water with a towel.
If evaporator unit continues to ice.	Observe ice formation pattern. If only part way up the coil face, evaporator unit could be low on refrigerant. If all the way up, the coil may be dirty or airflow is blocked.
Unit does not run/power up	
Possible Cause	Solution
Circuit breaker tripped	Reset breaker
Evaporator unit is not plugged in	Make sure the unit is plugged into an outlet
Power switch not on	Turn unit on by pressing the power button on the control
Line voltage is incorrect rating for the system	Check line voltage to make sure there is 110v/120v
Bottle at set point	Lower set point
Thermostat not calling for cooling	Lower set point
Faulty thermostat or wiring	Call Customer Service at 1-855-235-5271
Cellar Temperature is too Warm	
Possible Cause	Solution
The temperature of the room condensing unit is exhausting to has exceeded 110°F	Intake temperature needs to drop below 110°.
The system is undersized for the cellar.	Order correct size system
There is something blocking the supply and/or return air, on evaporator or condenser side of the unit	Remove air flow obstruction
Evaporator unit is mounted too low in the cellar	Re-Locate unit so the distance from the ceiling and top of the unit is no more than 18"
One or more of the fans is not turning on.	Call Customer Service at 1-855-235-5271
Compressor is not turning on.	Call Customer Service at 1-855-235-5271
Compressor keeps cycling on overload	Make sure all fans are working and there are no airflow obstructions
Poor seal around door.	Make sure there are no air gaps around the door. If door seal is damaged, replace it.
Controller set too high	Lower the set point.
Evaporator coil is frosted or iced up	Observe ice formation pattern. If only part way up the coil face, evaporator unit could be low on refrigerant. If so, call Customer Service at 1-855-235-5271

TROUBLESHOOTING GUIDE

Unit leaks water	
Possible Cause	Solution
Evaporator unit is not level	Evaporator unit should be level in wall to prevent leaking
Drain line clogged or kinked	Check drain line to make sure water can flow freely. Disconnect drain and clear out, open access door and check drain for blockage
Drain line does not have a downward slope	Fix Drain line so there is a downward slope from the unit to the drain.
Coil is iced causing drain pan ice and water overflowing	Melt ice with blow drier. Soak up with a towel
Unit runs but does not cool	
Possible Cause	Solution
Lack of air flow	Make sure fan is unobstructed; clean evaporator if necessary
Compressor not running	Call Customer Service at 1-855-235-5271
System undersized	Call Customer Service at 1-855-235-5271
Compressor is overheating	Shut system off for 1 hour to allow compressor to cool. Turn back on and check for cooler air flow out. If compressor runs, check for and clean condenser coil as possible cause of compressor overheating. If problem repeats, call customer service.
Evaporator fan runs but compressor does not	
Possible Cause	Solution
Running an Anti-Frost Cycle	Check evaporator coil temp.
Compressor and/or starting components faulty	Call Customer Service at 1-855-235-5271
System may be performing the CHM function	Allow cooling system to revert back to cooling mode.
Compressor may have overheated.	Shut system off for 1 hour to allow compressor to cool. Turn back on and check for cooler air flow out. If compressor runs, check for and clean condenser coil as possible cause of compressor overheating. If problem repeats, call customer service.
Compressor runs but evaporator fan does not	
Possible Cause	Solution
Faulty low pressure switch	Call Customer Service at 1-855-235-5271
Faulty Controller	Call Customer Service at 1-855-235-5271
Compressor short cycles	
Possible Cause	Solution
Leaking Solenoid Valve	Call Customer Service at 1-855-235-5271
System low on refrigerant charge	Call Customer Service at 1-855-235-5271
Condensing fan motor/capacitor faulty	Call Customer Service at 1-855-235-5271
Compressor and /or starting components faulty	Call Customer Service at 1-855-235-5271
TXV power element lost charge	Call Customer Service at 1-855-235-5271
Plugged Refrigerant Drier	Call Customer Service at 1-855-235-5271
Dirty Condenser Coil	Call Customer Service at 1-855-235-5271
Humidity in cellar too low	
Possible Cause	Solution
Not enough moisture	Add something like a water fountain to add humidity back in the room

TECHNICAL ASSISTANCE

CellarCool Customer Service is available Monday through Friday from 8:00 a.m. to 4:00 p.m. Pacific Time.

The customer service representative will be able to assist you with your questions and warranty information more effectively if you provide them with the following:

- The model and serial number of your CellarCool systems.
- Location of unit and installation details, such as ventilation, ducting, construction of your wine cellar, and room size. Photos of the cellar and installation location may be needed.

Contact CellarCool Customer Service

1738 E. Alpine Ave
Stockton, CA 95205
www.CellarCool.com
Email: support@cellarcool.com
Phone: (209) 466-9463
US Toll Free 1(855) 235-5271
Fax (209) 466-4606

ACCESSORIES FOR COOLING UNITS

CellarCool offers accessories to enhance and customize your wine cooling unit.

Condensate Pump Kit

The condensate pump kit is designed as an automatic condensate removal pump for water dripping out of our evaporator units' drain line. The pump is controlled by a float/switch mechanism that turns the pump on when approximately 2-1/4" of water collects in the tank, and automatically switches off when the tank drains to approximately 1-1/4". The condensate pump kit allows the excess condensate to be pumped up to 20ft away from the unit.

Accessories can be purchased at www.cellarcool.com

CellarCool Product Terms and Conditions Including Product Limited Warranty And Product Installation Requirements For CellarCool Split System Series

ATTENTION: PLEASE READ THESE TERMS OF USE CAREFULLY BEFORE INSTALLING YOUR CELLARCOOL COOLING SYSTEM. INSTALLING YOUR CELLARCOOL COOLING SYSTEM INDICATES THAT YOU ACCEPT AND AGREE TO EACH OF THE TERMS AND CONDITIONS SET FORTH HEREIN ("TERMS OF USE"). IF YOU DO NOT ACCEPT THESE TERMS OF USE, YOU RISK VOIDING YOUR WARRANTY AND ASSUMING ADDITIONAL REPAIR AND REPLACEMENT COSTS.

1. Purchase of a CellarCool Cooling System assumes that the Purchaser ("End User") fully accepts and agrees to the Terms and Conditions set forth in this document. The Terms and Conditions of Sale and Owner's Manual are shipped with each unit and, if another copy is needed, replacement copies can be downloaded from the company website (cellarcool.com) or by contacting CellarCool directly for a new copy. CellarCool reserves the right, in its sole discretion, to change its Terms and Conditions at any time, for any reason, without notice.

2. CellarCool Product Installation and Limited Warranty

- A. Purchaser of the product must arrange for the product to be installed by a certified HVAC/R technician in accordance with procedures set forth by CellarCool and described in the CellarCool Owner's Manual.
- B. The HVAC/R technician installing the product must complete the designated portion of the Split Startup Checklist and provide licensing or certification identification number information to assist in the warranty registration process.
- C. Purchaser must return the completed Split Startup Checklist to CellarCool within thirty (30) days of installation of Product. The Split Startup Checklist must be approved by CellarCool to activate the Limited Warranty. If the Split Startup Checklist is approved, Purchaser will be sent activation approval documents and will start receiving the benefits of the Limited Warranty throughout the warranty period. If the Split Startup Checklist is incomplete, Purchaser will be informed they have five days to complete the Split Startup Checklist and re-submit to CellarCool. The Split Startup Checklist will be reviewed again, and if denied, Purchaser will be informed that they have 10 business days for corrective action. Failure to register the Product may result in loss of warranty.
- D. Purchaser is responsible for the full costs of installation and any additional parts required for the proper and complete installation of the product.
- E. For Split Systems returned to CellarCool in accordance with the terms and conditions of the Limited Warranty, CellarCool warrants against defects in material and workmanship as follows:
 - 1. LABOR** - For a period of two (2) years commencing on the date of purchase, CellarCool will, at its option and discretion, reimburse up to \$250 to the End User for cost incurred for servicing, repairing, removing or installing warranty parts. Invoice for service must be forwarded to CellarCool for assessment and processing. The Split System warranty is invalid if there is attempted repair by anyone other than an HVAC/R technician approved by CellarCool to service the Product.
 - 2. PARTS** - For a period of two (2) years commencing on the date of purchase, CellarCool will supply, at no charge, new or rebuilt replacement parts in exchange for defective parts. Replacement parts are warranted only for the remainder of the original warranty period.
 - 3. FREIGHT** - For a period of two (2) years commencing on the date of purchase, if after CellarCool approved evaluation the original Product failure is determined to be the cause of a manufacturers defect, and not the cause of an installation error or other cause, CellarCool will cover at its option, freight for the replacement parts or Product.

The following part or cause of failure is not the responsibility of CellarCool:

- Improper voltage supply
- Line set with screw connectors (high end and low end)
- Leaks found at the braze points when performing pressure check
- Unit that has been charged incorrectly
- Incorrect tubing diameter used on line set
- A unit that has been wired incorrectly
- Valve stem on condenser side
- Improper installation of P-Trap
- Lack of P-Trap (if required)
- Condensers that are installed outdoors or in elements that would affect operation without proper cover or housing. (Housing is available from Manufacturer).

Product Warranty Limitations and Exclusions.

1. This limited warranty does not cover cosmetic damage caused during installation, damage due to acts of God, commercial use, accident, misuse, abuse, negligence, or modification to any part of the Product. Delivery and installation of the Product, any additional parts required, as well as removal of the Product if warranty work is required, are all at the sole cost, risk and obligation of the End User.
2. This limited warranty does not cover damage due to improper installation or operation or lack of proper maintenance of the Product, connection of the Product to improper voltage supply, or attempted repair of the Product by anyone other than a technician approved by CellarCool to service the Product.
3. This limited warranty does not cover any Product sold "AS IS" or "WITH ALL FAULTS."
4. Product that has been replaced during warranty period does not extend the warranty period past the original date of purchase.
5. This limited warranty is valid only in the continental United States. Sales elsewhere are excluded from this warranty.
6. Proof of purchase of the Product in the form of a bill of sale, receipted invoice or serial number, which is evidence that the Product is within the Limited Warranty Period, must be presented by the End User to CellarCool in order to obtain limited warranty service.
7. This limited warranty is void if the factory applied serial number has been altered or removed from the Product.
8. This limited warranty is voided if installed in an enclosure of insufficient design that does not follow the Product installation requirements stated herein and in the owner's manual.
9. Removing the rivets from the Product's unit housing without prior authorization from CellarCool voids this limited warranty.
10. The End User must first contact CellarCool Customer Service by telephone (at 1-855-235-5271) prior to attempting service on any Product still under the limited warranty; else the limited warranty is voided.
11. This limited warranty does not cover Product being concealed by, but not limited to, vegetation, fabric, shelving, mud, snow, or dirt. Product must not be painted or limited warranty will be void.
12. This limited warranty does not cover exposure to corroding environments such as, but not limited to, petroleum and gasoline products, cleaning solvents, caustic pool chemicals, and marine air.
13. This limited warranty does not cover any cause not relating to Product defect.
14. THE REPAIR OR REPLACEMENT OF THE PRODUCT AS PROVIDED UNDER THIS LIMITED WARRANTY IS THE EXCLUSIVE REMEDY OF YOU, THE END USER, AS WELL AS ANYONE ELSE IN THE CHAIN OF TITLE OF THE PRODUCT, DOES NOT START A NEW LIMITED WARRANTY TIME PERIOD, AND IS IN LIEU OF ALL OTHER WARRANTIES (EXPRESS OR IMPLIED) WITH REGARD TO THE PRODUCT. IN NO EVENT SHALL CELLARCOOL BE LIABLE FOR INCIDENTAL, CONSEQUENTIAL, SPECIAL OR CONTINGENT DAMAGES FOR BREACH OF ANY EXPRESS OR IMPLIED WARRANTY ON THIS PRODUCT. THE IMPLIED WARRANTIES OF MERCHANTABILITY AND FITNESS FOR A PARTICULAR PURPOSE ARE HEREBY EXPRESSLY DISCLAIMED. Some states do not

1. allow the exclusion or limitation of incidental or consequential damages, or allow limitations on how long an implied warranty lasts, so the above limitations or exclusions may not apply to you. This limited warranty gives you specific legal rights, and you may have other rights, which vary from state to state.
2. Failure of the End User to comply with all of the Product Installation Requirements, Maintenance Requirements and End User Requirements may, at CellarCool's sole discretion, void this limited warranty.
3. No one has any authority to add to or vary the limited warranty on this Product.

3. Maintenance Requirements

The End User is responsible for checking the coils on the condenser unit and vacuuming them every three months to maintain them free of debris. It is the End User's responsibility to clean off any accumulated dust, lint, or other debris from the front and rear intake grills; failure to do this on a regular basis will restrict the airflow and may affect the Product's ability to function properly. Periodically cleaning the Product's vents will help assure maximum cooling efficiency. The drain tube must also be checked and kept clean and free of debris and mold to maintain proper performance.

Mold is a natural living organism in the environment. It exists in the air in the form of microscopic spores that move in and out of buildings through doors, windows, vents, HVAC systems and anywhere else that air enters. Once it is discovered, mold must be addressed quickly and appropriately. Delayed or improper treatment of mold issues can result in costly and reoccurring repairs. If the End User suspects a mold problem, it is always best to hire a qualified and experienced mold remediation specialist.

4. Additional End User Costs And Responsibilities

Terms and conditions for replacing the Product that is being evaluated for limited warranty.

1. After evaluation by a certified HVAC/R technician and the Product is found to be un-repairable in the field, contact CellarCool Customer Service to arrange for replacement under the warranty guidelines. When a claim for warranty is submitted for a condenser skid, the End User must purchase a new condenser skid from CellarCool at retail price. Upon installation of the new condenser skid by a certified HVAC/R Technician, the HVAC/R Technician must complete the Installation Checklist and End User must submit the Installation Checklist to CellarCool Customer Service for approval. The original condenser skid must be returned within 21 days to CellarCool for failure analysis. If the Installation Checklist is approved and the failure is evaluated as defective and not installation error or other reason, the End User will be refunded for the cost of the replacement skid.
2. If the Product failure is evaluated and it is determined that it is an installation error or other reason, all costs, including shipping will be the responsibility of the End User.

The following items are not covered under any warranty and are the sole responsibility of the End User:

- A. End Users should satisfy themselves that the Product they are purchasing is suitable for their particular needs and requirements, and thus no responsibility will be placed with CellarCool for the End User's decisions in this regard.
- B. End Users must assure that the product is installed by a certified HVAC/R technician. Failure to do so will result in Voiding the Limited Warranty.
- C. It is the End User's responsibility to secure safe haven/storage for ANY AND ALL items that are being kept and stored in the End User's wine cellar, including any Product. CellarCool takes no responsibility for the safety and preservation of the aforementioned items in the event that the environment becomes unsuitable to maintain a proper storage environment.
- D. End User is responsible for initial installation costs, including, but not limited to, labor costs and the cost of any additional parts necessary to complete the installation.
- E. End User is responsible for all costs incurred for the installation and/or removal of the Product, or any part thereof, unless such cost has been agreed by CellarCool to be a warranty repair prior to the work being performed.

5. Sales and Use Tax

CellarCool only collects California sales tax for orders shipped within the State of California; CellarCool does not collect sales tax for orders shipped to other states. However, the Purchaser and the End User may be liable to the taxing authority in their state for sales tax and/or use tax on the Product. The Purchaser and the End User should each check with their state's taxing authority for sales and use tax regulations.

6. Customer Service and Troubleshooting

CellarCool's customer service department is available to answer any questions or inquiries for End Users regarding a CellarCool Product, as well as to assist in performing basic troubleshooting, Monday through Friday, from 6:30 a.m. to 4:00 p.m. PST, at telephone number 1-855-235-5271. CellarCool reserves the right to have a certified, CellarCool-approved, HVAC/R technician go on site and inspect the product if the initial trouble shooting warrants further investigation. CellarCool Corporation is located at 1738 East Alpine Avenue, Stockton, California 95205.

7. Request for Product Evaluation and Repair Under Warranty

SPLIT SYSTEM FIELD SERVICE WARRANTY POLICY: This Policy is to clarify what falls under Warranty Service and what becomes the responsibility of the Owner. CellarCool ("manufacturer") strives to provide our customers with a superior Product and we back our Product with a Two Year Limited Warranty. Please review the CellarCool Product Terms and Conditions including Product Limited Warranty and Product Installation Requirements to ensure you have a complete understanding of our Policy and coverage of your Split System.

ARBITRATION: Any disputes arising out of or in connection with the installation and warranty of the Split System shall be referred to and finally resolved by a CellarCool approved Independent Certified HVAC/R Technician. The evaluation of the Technician on all issues or matters of identifying the responsible party (CellarCool or Installing Technician) shall be determined in a written report. This report will be made available to all concerned parties. If discovered under warranty, CellarCool will assume the financial responsibility under their warranty guidelines. If the report finds the Owner's Installer as the responsible party, CellarCool will provide all documentation to the customer to substantiate the findings. This will include the Invoice from the Independent Certified HVAC/R Technician and the written report of the findings. The Owner will become responsible for payment directly to CellarCool for all charges incurred for repairs (labor, parts and shipping costs) on the Split System.

8. Miscellaneous Terms and Conditions

- A. **Return Policy.** All return inquiries must be made within thirty (30) calendar days of the original purchase of a Product and are subject to a twenty five percent (25%) restocking fee. Shipping costs are not refundable and the Purchaser is responsible for all return shipping costs (including customs fees and duties, if applicable).
- B. **Security Interest.** CellarCool retains a security interest in each Product until payment in full.
- C. **Construction and Severability.** Every provision of these Terms and Conditions shall be construed, to the extent possible, so as to be valid and enforceable. If any provision of these Terms and Conditions is held by a court of competent jurisdiction to be invalid, illegal or otherwise unenforceable, such provision will, to the extent so held, be deemed severed from the contract of sale between Purchaser and CellarCool, and all of the other non-severed provisions will remain in full force and effect.
- D. **Governing Law/Choice of Forum.** The laws of the State of California (without regard for conflicts of law) shall govern the construction and enforcement of the these Terms and Conditions of Sale (Sections 1 through 9 inclusive, including Product Limited Warranty And Product Installation Requirements), and further these Terms and Conditions of Sale shall be interpreted as through drafted jointly by CellarCool and Purchaser. Any dispute will be resolved by the courts in and for the County of San Joaquin, State of California, and all parties, CellarCool, Purchaser and End User, hereby irrevocably submit to the personal jurisdiction of such courts for that purpose. No waiver by CellarCool of any breach or default of the contract of sale (including these Terms and Conditions of Sale) concerning a Product will be deemed to be a waiver of any preceding or subsequent breach or default.
- E. **Correction of Errors and Inaccuracies.** These Terms and Conditions may contain typographical errors or other errors or inaccuracies. CellarCool reserves the right to correct any errors, inaccuracies or omissions, and to change or update these Terms and Conditions, at any time without prior notice.

9. Questions, Additional Information And Technical Assistance

- A. **Questions.** If you have any questions regarding these Terms and Conditions or wish to obtain additional

information, contact us via phone at 1-855-235-5271 or please send a letter via U.S. Mail to:

Customer Service
CellarCool Corporation
1738 E Alpine Ave
Stockton, CA 95205

Email: support@cellarcool.com
Web: www.cellarcool.com

B. Technical Assistance. CellarCool Customer Service is available Monday through Friday from 6:30 a.m. to 4:00 p.m. PST. The Customer Service representative will be able to assist you with your questions and warranty information more effectively if you provide them with the following:

1. The model and serial number of your CellarCool UNIT.
2. The location of the system and installation details, such as ventilation, construction of your wine cellar, and room size.

Model **HM&VM** Serial Number **C**

Installed by _____ Date _____

CELLARCOOL

CellarCool
1738 E. Alpine Ave
Stockton, CA 95205
1 (855) 235-5271
www.cellarcool.com