

BROAN® B33DHW



FEATURING A SLIM-PROFILE THE **B33DHW** IS DESIGNED TO BE MOUNTED IN OR ON AN INTERIOR WALL MAKING IT EASY TO BRING MOISTURE CONTROL INTO SMALLER AREAS WITHOUT GIVING UP ANY FLOOR SPACE. INTEGRATED DIGITAL HUMIDITY CONTROLS MAKE IT AN EASY SETUP PROCESS.

PERFORMANCE

Water Removal	33 Pints / 4.125 Gallons
Efficiency	4.25 Pints/kWh
Energy Factor	2.0 L/kWh
Blower	155 CFM @ 0.0" WG
Operating Temperature	49°F Min., 95°F Max.
Sizing	Up to 1,200 Sq. Ft. / 12,000 Cu. Ft.

ELECTRICAL

Power	324 watts @ 80°F and 60% RH
Supply Voltage	120 VAC – 1 phase – 60 Hz
Current Draw	2.8 amps
Power Cord	10', 115 VAC, Ground
Circuit Requirement	15 Amps



SPECIFICATIONS

Sound Rating	46 dBA
Drain Connection	3/4" O.D.
Drain Hose	10" Condensate Hose (3/4" ID)
Refrigerant	R134A, 10 oz.
Unit Dimensions	14.875"W x 30"H x 5.75"D
Unit Weight	39 lbs.

SHIPPING

Shipping Dimensions	20"W x 37"H x 11"D
Shipping Weight	57 lbs.
Pallet Quantity	8 per pallet

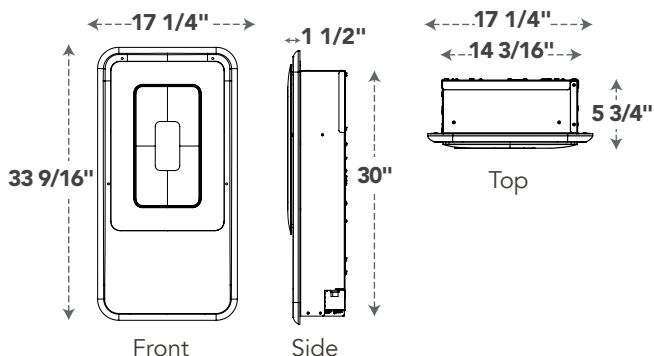

FEATURES

- Designed for quiet operation
- Washable air filter
- Ability to be hardwired into existing electrical or directly plugged into a 110v outlet
- Designed to drain into a hub-drain or plumbing line
- Internally mounted digital dehumidistat
- Paintable white cover allows this dehumidifier to blend in with any wall color and texture

TYPICAL APPLICATIONS

- Condo
- Apartment
- Student Housing
- Hospitality
- Basement
- Townhome

BROAN
NuTone
COME HOME TO FRESH AIR

Specifications are subject to change without notice. Performance is based on pints / gallons per day @80°F/60%RH. Sizing is based on 10 foot ceiling height. Unit dimensions and weight are with collars on.

FILTRATION

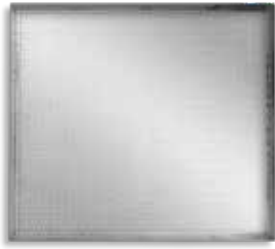

WASHABLE FILTER

- For large particle filtration
- Easy to clean every 1-2 months
- Simple to remove and replace

INSTALLATION



SURFACE MOUNT KIT

- Slim profile
- Easy installation
- Ideal for masonry or CMU block wall applications or when through-the-wall installation is not available
- Powder-coated metal provides polished look to blend into any environment



2X4 WALL MOUNT BEZEL KIT

- Slim profile
- Easy installation
- Ideal for applications with a 2x4 cavity without having to cut a hole in both sides of the drywall
- Powder-coated metal provides polished look to blend into any environment



REAR PANEL KIT

- Easy installation
- Ideal for 2x4 cavity applications that require covering the back of the dehumidifier or to conceal gaps in drywall
- Powder-coated metal attaches to rear of dehumidifier providing a polished look to blend into any environment

Parts

S4036923	Power Board	S4038144	Diffuser with Filter and Sound Dampening Insulation
S4038072	Control Board	S4038001	3/4" Crush Resistant Hose (10')
S4037714	Filter	S4037916	Tamper Resistant Screws
S4037585	Blower	S4035235-08	Compressor Capacitor
S4036848	Temperature / RH Sensor	S4035235-01	Blower Capacitor
S4037996	Hose Clamp	S4038145	Defrost Probe Kit

Specifications subject to change without notice.

Part No.	Item
DHA4037714	Washable Filter

Part No.	Item
DHA4037766	Surface Mount Kit

Part No.	Item
DHA4037767	2x4 Wall Mount Bezel Kit

Part No.	Item
DHA4037768	Rear Panel Kit



Broan-NuTone LLC | Hartford, Wisconsin 53027
 800-558-1711 | Broan-NuTone.com
 ©2021 Broan-NuTone LLC | Printed in U.S.A.
 99851129A | 08/21