



Packaged Pressure Booster Systems

Package water pump system consists of pump(s), pressure tank, pressure sensor(s), flow switch, pressure gauge, valves, piping, and control panel. All are mounted and assembled on a common galvanized steel base.

Automatic water pressure system for:

- Household, commercial & industrial applications
- Multi-dwelling water supply system
- Turf watering & irrigation
- Water supply, boosting & transfer
- Car wash
- Water features
- And more

Features and Benefits

- Package systems assembled on a common steel base plate
- Captive diaphragm pressure tank.
- Copper manifolds
- Stainless steel braided flexible tank connection
- Reliable sensor for efficient pump control
- Adjustable pressure sensing system
- Liquid filled pressure gauge
- UL approved control panel
- CSA or UL approved pump motor
- NEMA 1 control panel
- High efficiency pump design providing smooth and quiet operation
- Flat pump curves “on larger pumps” means system gives stable pressure boost without use of a pressure reducing valve
- Captive diaphragm pressure tank with butyl rubber diaphragm, creases, bacteria resistant, potable water approved
- Brass lead free isolating ball valve and spring loaded check valves.



Operating Limits

Capacities to.....	300 gpm
Boost pressures to.....	.67 psi
Maximum ambient temperature.....	.120°F
Maximum inlet pressure.....	.50 psi
Maximum operating pressure.....	.125 psi

Suitable Fluids

Clean, clear, non-corrosive, non-flamables

SYSTEM SPECIFICATIONS

MODEL 12 = 1 ph 32 = 3 ph	GEBS5040-12 GEBS5040-32	GEBS6040-12 GEBS6040-32	GEBS9040-32	GEBD10040-12 GEBD10040-32	GEBJ7040-12 GEBJ7040-32	GEBD14040-12 GEBD14040-32	GEBD18040-32
Maximum Flow(GPM)	55	110	150	110	80	220	300
Maximum Boost Pressure (PSI)	67	50	50	67	77	50	50
Design Point	50 @ 40	60 @ 40	90 @ 40	100 @ 40	70 @ 40	140 @ 40	180 @ 40
Pump	D36210/1 D36210/3	C25624/1 C25624/3	C25638/3	D36210/1 D36210/3	RB204-F C25624/1 C25624/3	C25624/1 C25624/3	C25438/3
Suction	1 1/4"	2"	2"	2"	2"	3" Flange	3" Flange
Discharge	1 1/4"	2"	2"	2"	2"	3" Flange	3" Flange
Horsepower	2	3	5	2 and 2	1 and 3	3 and 3	5 and 5
Enclosure	NEMA 1	NEMA 1	NEMA 1	NEMA 1	NEMA 1	NEMA 1	NEMA 1
Function	Pressure Sensor with Run timer	Pressure Sensor with Run timer	Pressure Sensor with Run timer	Lead & Lag Pressure Sensor with Run timer	Flow switch with Run timer	Lead & Lag Pressure Sensor with Run timer	Lead & Lag Pressure Sensor with Run timer
Tank	40 Gallon	40 Gallon	40 Gallon	40 Gallon	40 Gallon	40 Gallon	40 Gallon
Based	Galvanized Steel						

SYSTEM IDENTIFICATION

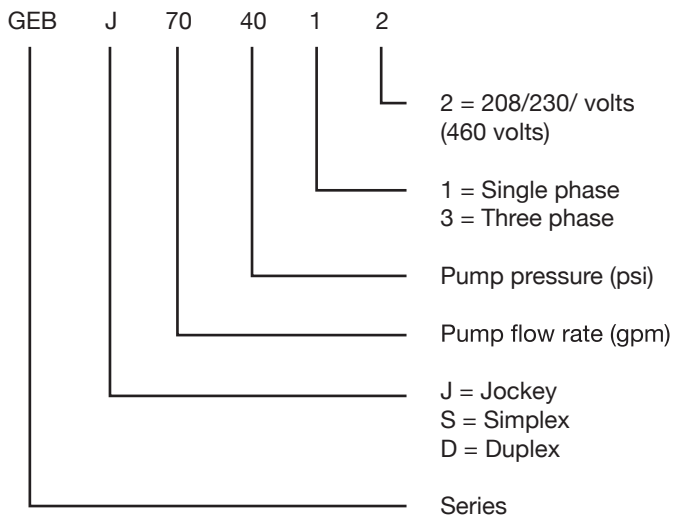

GEBS5040-12

GEBS models

GEBS models utilize the D36210 or C2 series single or three phase pump. This system is controlled by a pressure sensor for starting and stopping the pump. The control panel includes an HOA switch (hand-off auto), run light, contactor, minimum run timer and UL listing.

Example applications include light commercial, industrial irrigation, large residences and agriculture.



GEBS10040-12

GEBJ models

GEBJ models combine the reliable control of the JCR series pump with the performance of the D36210 series pump activated by a flow switch during high demand.

Benefits include:

- Smaller pump runs approx. 80-85% of time
- Substantial energy operating cost savings
- Meets codes where duplex is required for all commercial applications regardless of size

The control panel includes an HOA switch (hand-off auto), run light, contactor, minimum run timer and UL listing.

Example applications include small hotels, restaurants, large homes, small motels, parks and office buildings.



GEBJ7040-12

GEBD models

Depending on the specific model, GEBD models utilize the D36210 or C2 series pumps. The system is controlled by an adjustable pressure sensing device for starting and stopping the lead pump and engaging the lag pump during high flow. Lead and lag pumps alternate after each run sequence. The control panel includes HOA switches (hand-off auto) run light, contactor, run timer, alternator with pump selection switch and UL listing.

Example applications include hotels, apartment buildings, larger motels, condo buildings, parks, office buildings, strip malls and government buildings.



GEBD14040-12

Contact *Aqua Pro Pump Systems* for custom built systems with high pressure pumps, VFD'S, stainless steel headers AND MORE!

HYDRAULIC PERFORMANCE

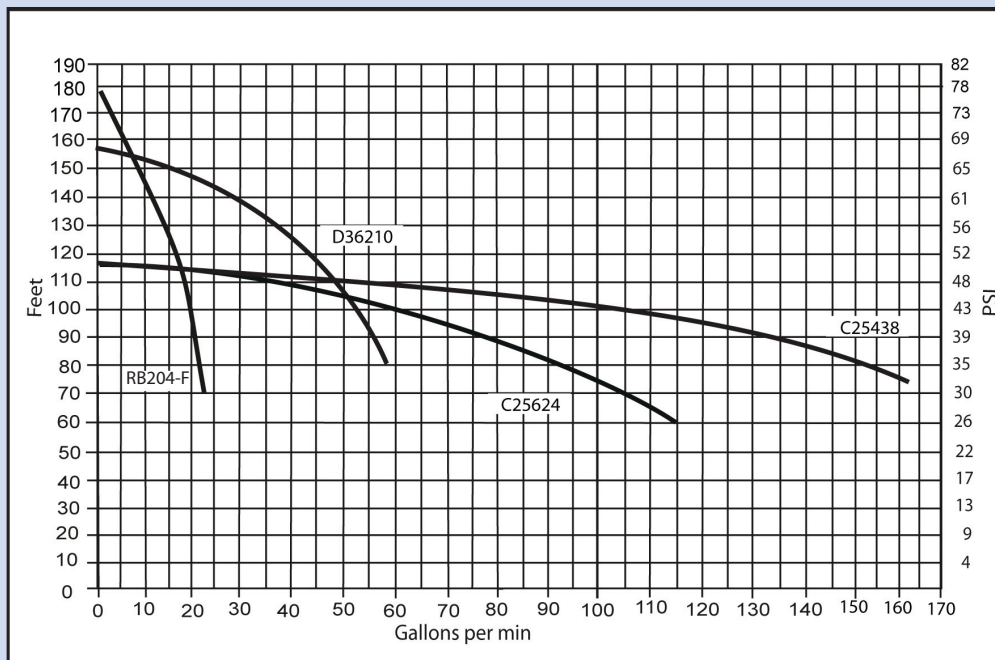

ELECTRICAL DATA

Pump	RB204-F	C25624/1	C25624/3	C25438/3	D36210		
Supply voltage	115	208/230	208/230/460		208/230		
Supply frequency	60Hz						
Phase	Single		Three			Single/Three	
Full load amps	10.2A	13.1A	9A	4.5A	12A	6A	10/6
Locked rotor amps	38.0A	90A	95A	47.5A	95A	47.5A	51/46
Output power (hp)	1	3	3	5		2	
Insulation	Class F						

MATERIALS OF CONSTRUCTION

Parts	Material
Pump (D36210)	Stainless
Pump (C2)	Stainless
Pump (RB204-F)	Stainless steel
Motor	ODP/TEFC 56J
Mechanical seal	S/B Car/Cer/Buna
Tank shell	Epoxy coat steel
Diaphragm	Butyl rubber
Manifold	Copper
Tank connection	Stainless Steel flexible hose
Pressure Sensors & gauges	Sensors, brass connection w/ thermal plastic enclosures Gauges, liquid filled w/ stainless steel case

MAXIMUM TOTAL SUCTION LIFT

Total suction lift up to 20'. For larger suction lifts, contact Aqua Pro Pump Systems.

POWER LIMITS

Single phase power 1 x 208-203 ± 10% 60Hz
 Three phase power 3 x 208-230/460±10% 60Hz
 Other voltages and power supplies available upon request.

Contact *Aqua Pro Pump Systems* for custom built systems with high pressure pumps, VFD'S, stainless steel headers AND MORE!

Visit us on the web at tomiko.com



MODEL: GEBS5040-12	
Pressure booster system for large residential homes and light commercial buildings. These systems come standard with NEMA 1 control panels, contactors, overloaders, alternators, HOA switches, minimum run timers, and transformers in 3 phase models.	
DESIGN DATA	
Max Flow	55 GPM
Max Pressure Boost	67 PSI (155')
Pressure Range	5-80 PSI Pre Set 40/60
Adj. Minimum Run Timer	Pre Set 7-10 seconds
Pressure Gauge	2" Stainless Liquid Filled 0-160 psi
Suction and Discharge	1-1/4"
Tank Capacity	40 gallon
Electrical Voltage and Phase	200-230 V - 1 PH
Motor	ODP
Horse Power	2
Max Pressure Rating	125 PSI
CONSTRUCTIONS MATERIALS	
Pump body	Stainless Steel
Impeller	Stainless Steel
Shaft	Stainless Steel
Seal	Carbon/Cermaic
Header	Copper
Ball Valves	Lead Free Brass
Check Valves	Lead Free Brass
Expansion Tank	Steel
Diaphragm	Butyl
Base Plate	Galvanized Steel
SUBMITTAL DATA	
JOB NAME	
LOCATION	
ENGINEER	
CONTRACTOR	
DISTRIBUTOR	
SALES REP	
All Systems Require Minimum of 10 PSI Incoming Pressure	
	Aqua Pro Pump Systems
	sales@tomikoinc.com

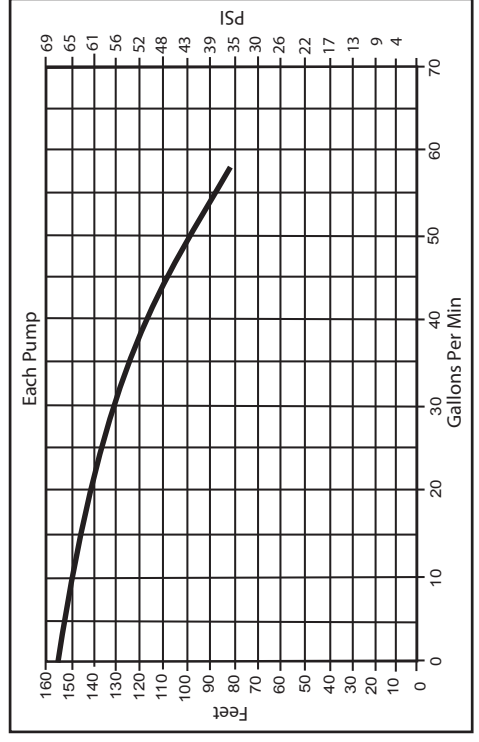
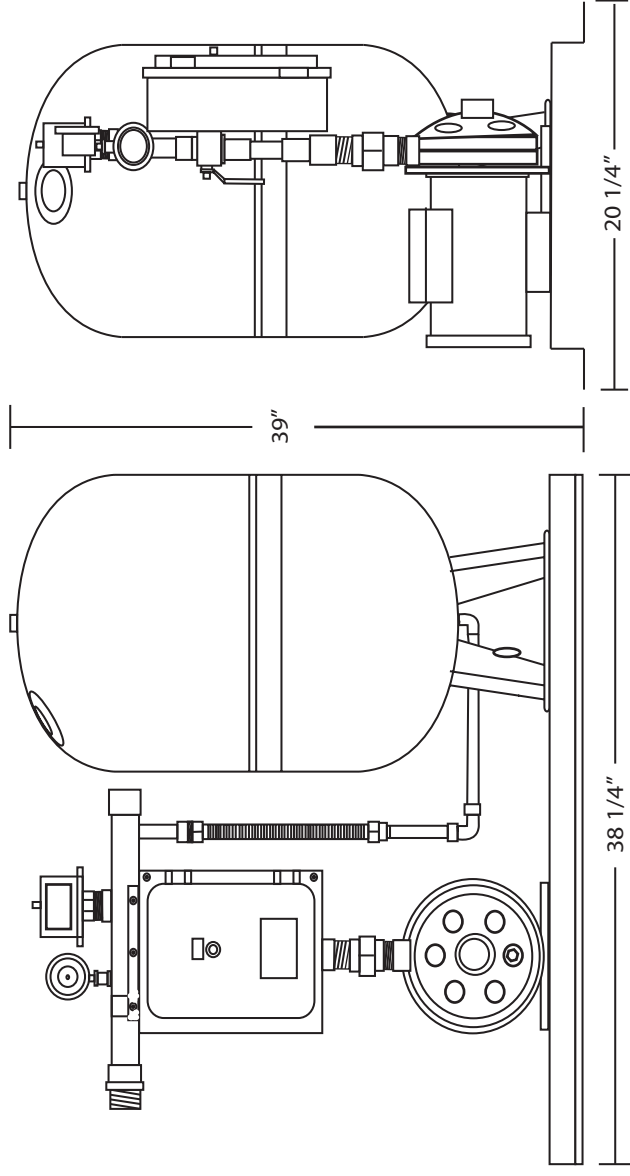



MODEL: GEBS6040-32	
Pressure booster system for large residential homes and light commercial buildings. These systems come standard with NEMA 1 control panels, contactors, overloads, alternators, HOA switches, minimum run timers, and transformers in 3 phase models.	
DESIGN DATA	
Max Flow	115 GPM
Max Pressure Boost	50PSI (115')
Pressure Range	5-80 PSI Pre Set 40/60
Adj. Minimum Run Timer	Pre Set 7-10 seconds
Pressure Gauge	2" Stainless Liquid Filled 0-160
Suction and Discharge	2" X 2"
Tank Capacity	40 gallon
Electrical Voltage and Phase	200/230/1 or 230/460/3
Motor	ODP
Horse Power	3
Max Pressure Rating	125 PSI
CONSTRUCTIONS MATERIALS	
Pump body	Stainless Steel
Impeller	Stainless Steel
Shaft	Stainless Steel
Seal	Carbon/Ceramic
Header	Copper
Ball Valves	Lead Free Brass
Check Valves	Lead Free Brass
Expansion Tank	Steel
Diaphragm	Butyl
Base Plate	Galvanized Steel
SUBMITTAL DATA	
JOB NAME	
LOCATION	
ENGINEER	
CONTRACTOR	
DISTRIBUTOR	
SALES REP	
All Systems Require Minimum of 10 PSI Incoming Pressure	
Aqua Pro Pump Systems	
sales@tomikoinc.com	

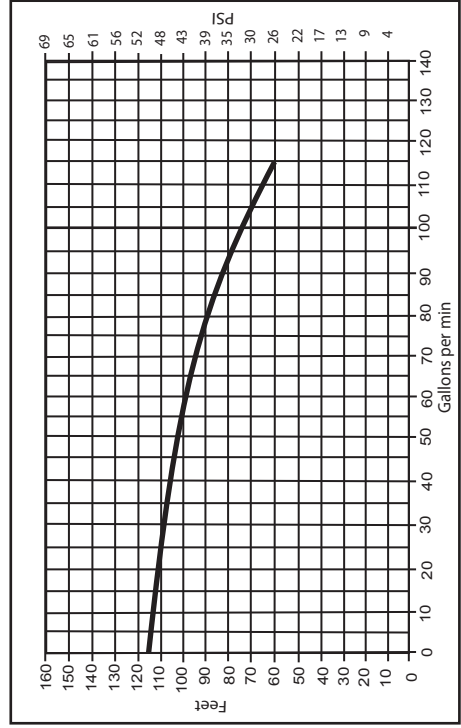
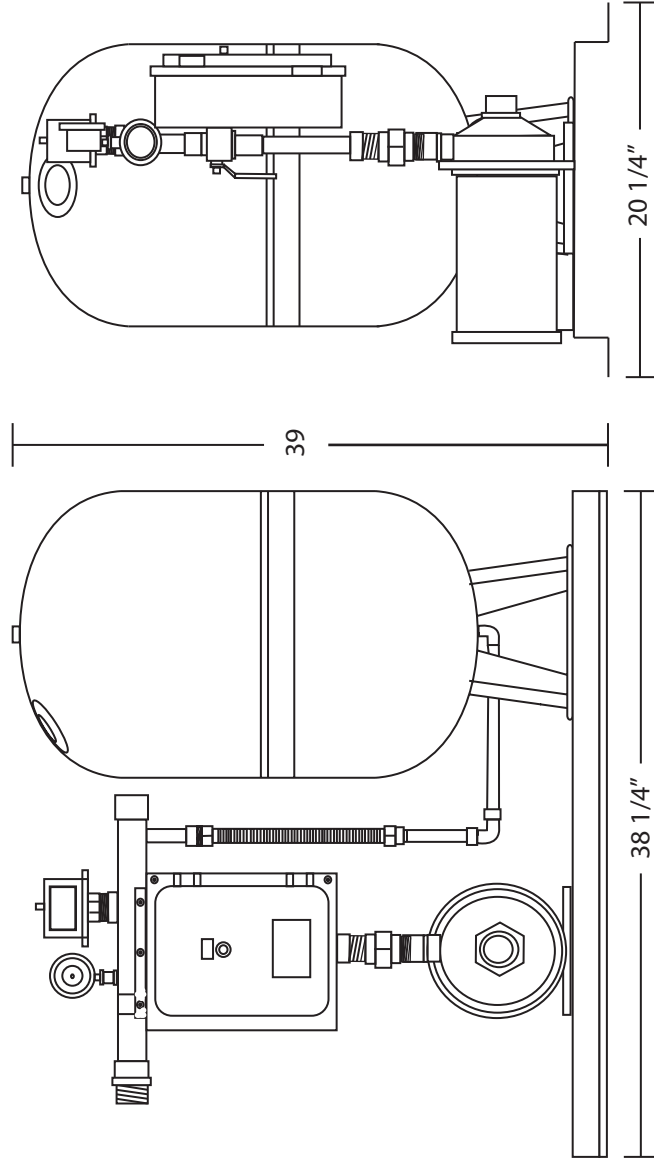



MODEL: GEBS9040-32	
Pressure booster system for large residential homes and light commercial buildings. These systems come standard with NEMA 1 control panels, contactors, overloads, alternators, HOA switches, minimum run timers, and transformers in 3 phase models.	
DESIGN DATA	
Max Flow	168 GPM
Max Pressure Boost	51 PSI (117')
Pressure Range	5-80 PSI Pre Set 40/60
Adj. Minimum Run Timer	Pre Set 7-10 seconds
Pressure Gauge	2" Stainless Liquid Filled 0-160
Suction and Discharge	2"X 2"
Tank Capacity	40 gallon
Electrical Voltage and Phase	208/230/460/3
Motor	ODP
Horse Power	5
Max Pressure Rating	125 PSI
CONSTRUCTIONS MATERIALS	
Pump body	Stainless Steel
Impeller	Stainless Steel
Shaft	Stainless Steel
Seal	Carbon/Cermaic
Header	Copper
Ball Valves	Lead Free Brass
Check Valves	Lead Free Brass
Expansion Tank	Steel
Diaphragm	Butyl
Base Plate	Galvanized Steel
SUBMITTAL DATA	
JOB NAME	
LOCATION	
ENGINEER	
CONTRACTOR	
DISTRIBUTOR	
SALES REP	
All Systems Require Minimum of 10 PSI Incoming Pressure	
Aqua Pro Pump Systems	
sales@tomikoinc.com	

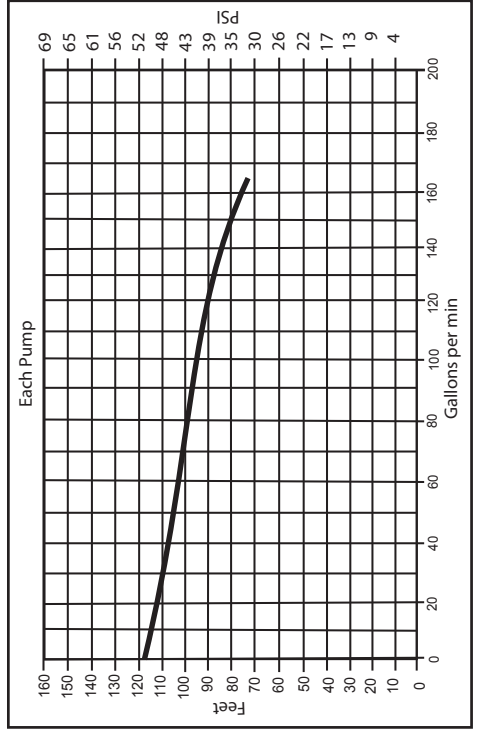
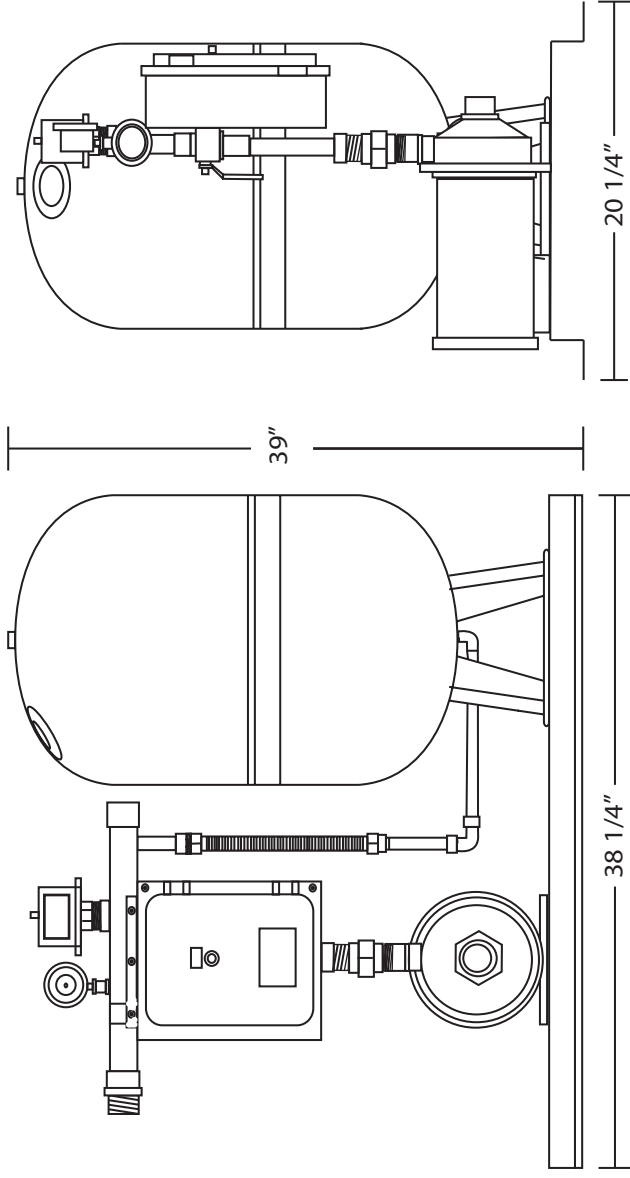



MODEL: GEBJ7040-12/32	
Pressure booster system for large residential homes and light commercial buildings. These systems come standard with NEMA 1 control panels, contactors, overloads, alternators, HOA switches, minimum run timers, and transformers in 3 phase models.	
DESIGN DATA	
Max Flow	80 gpm
Max Pressure Boost	78 psi (180')
Pressure Range	5-80 PSI Pre Set 40/60
Adj. Minimum Run Timer	Pre Set 7-10 seconds
Pressure Gauge	2" Stainless Liquid Filled 0-160
Suction and Discharge	2"X 2"
Tank Capacity	40 gallon
Electrical Voltage and Phase	115/208/1-208/460
Motor	Jockey TEFC / Pump ODP
Horse Power	Jockey 1/2HP - Pump 2hp
Max Pressure Rating	125 PSI
CONSTRUCTIONS MATERIALS	
Pump body	Stainless Steel
Impeller	Stainless Steel
Shaft	Stainless Steel
Seal	Carbon/Ceramic
Header	Copper
Ball Valves	Lead Free Brass
Check Valves	Lead Free Brass
Expansion Tank	Steel
Diaphragm	Butyl
Base Plate	Galvanized Steel
SUBMITTAL DATA	
JOB NAME	
LOCATION	
ENGINEER	
CONTRACTOR	
DISTRIBUTOR	
SALES REP	
All Systems Require Minimum of 10 PSI Incoming Pressure	
	Aqua Pro Pump Systems
	sales@tomikoinc.com

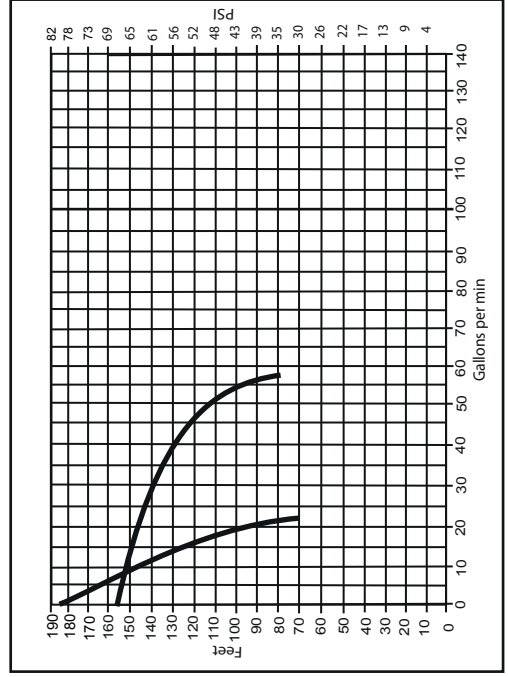
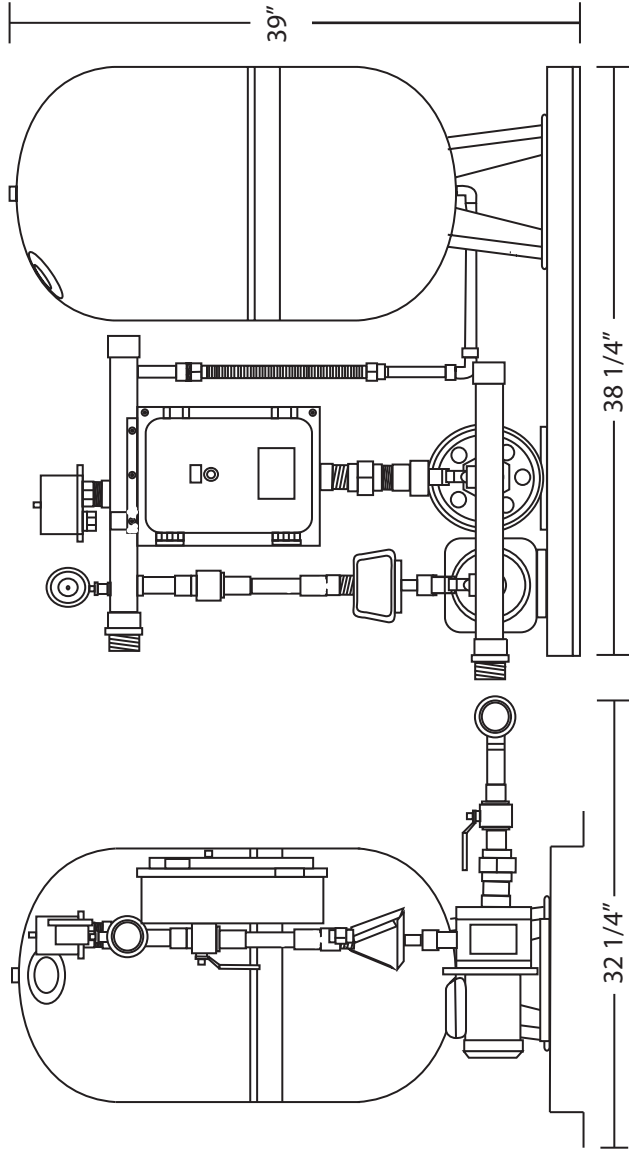



Aqua Pro Pump Systems

a Tomiko Inc. Company

MODEL: GEBD10040-12/32	
Pressure booster system for light to medium sized commercial buildings. These systems come standard with NEMA 1 control panels, contactors, overloads, alternators, HOA switches, minimum run timers, and transformers in 3 phase models.	
DESIGN DATA	
Max Flow	110 GPM
Max Pressure Boost	67 PSI (155')
Pressure Range	5-80 PSI Pre Set 40/60
Adj. Minimum Run Timer	Pre Set 7-10 seconds
Pressure Gauge	2" Stainless Liquid Filled 0-160 PSI
Suction and Discharge	2" X 2"
Tank Capacity	40 gallon
Electrical Voltage and Phase	200-230/1 OR 200/460/3
Motor	ODP
Horse Power	2-2HP
Max Pressure Rating	125 PSI
CONSTRUCTIONS MATERIALS	
Pump body	Stainless Steel
Impeller	Stainless Steel
Shaft	Stainless Steel
Seal	Carbon/Ceramic
Header	Copper
Ball Valves	Lead Free Brass
Check Valves	Lead Free Brass
Expansion Tank	Steel
Diaphragm	Butyl
Base Plate	Galvanized Steel
SUBMITTAL DATA	
JOB NAME	
LOCATION	
ENGINEER	
CONTRACTOR	
DISTRIBUTOR	
SALES REP	
All Systems Require Minimum of 10 PSI Incoming Pressure	
	Aqua Pro Pump Systems
	sales@tomikoinc.com

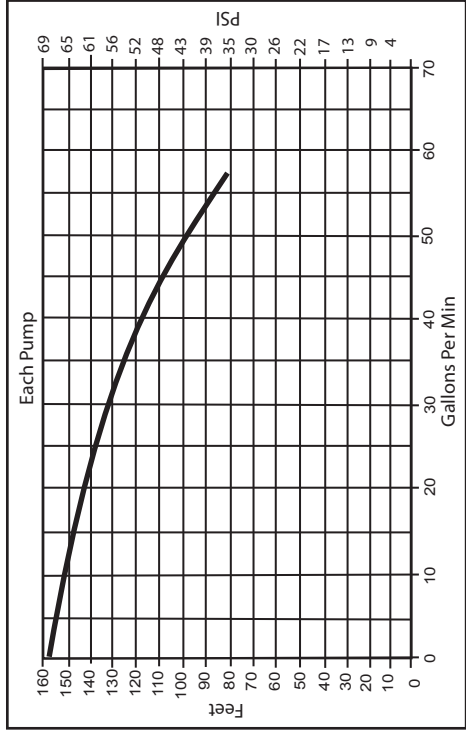
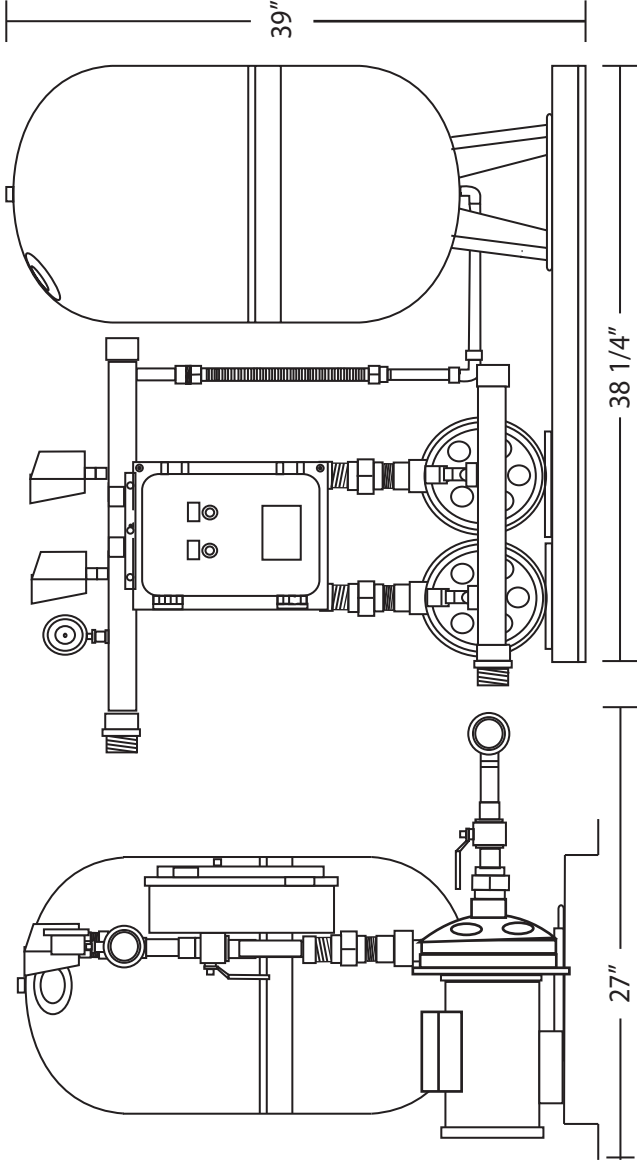



MODEL: GEBD14040-12/32	
Pressure booster system for larger residential homes and light commercial buildings. These systems come standard with NEMA 1 panels, contactors, overloads, alternators, HOA switches, minimum run timers, and transformers in 3 phase models.	
DESIGN DATA	
Max Flow	230 GPM
Max Pressure Boost	50 PSI (115')
Pressure Range	5-80 PSI Pre Set 40/60
Adj. Minimum Run Timer	Pre Set 7-10 seconds
Pressure Gauge	2" Stainless Liquid Filled 0-160
Suction and Discharge	3"X 3"
Tank Capacity	40 gallon
Electrical Voltage and Phase	200-230/ 1 or 200-460/3
Motor	ODP
Horse Power	2-3HP
Max Pressure Rating	125 PSI
CONSTRUCTIONS MATERIALS	
Pump body	Stainless Steel
Impeller	Stainless Steel
Shaft	Stainless Steel
Seal	Carbon/Ceramic
Header	Copper
Ball Valves	Lead Free Brass
Check Valves	Lead Free Brass
Expansion Tank	Steel
Diaphragm	Butyl
Base Plate	Galvanized Steel
SUBMITTAL DATA	
JOB NAME	
LOCATION	
ENGINEER	
CONTRACTOR	
DISTRIBUTOR	
SALES REP	
All Systems Require Minimum of 10 PSI Incoming Pressure	
	Aqua Pro Pump Systems
	sales@tomikoinc.com

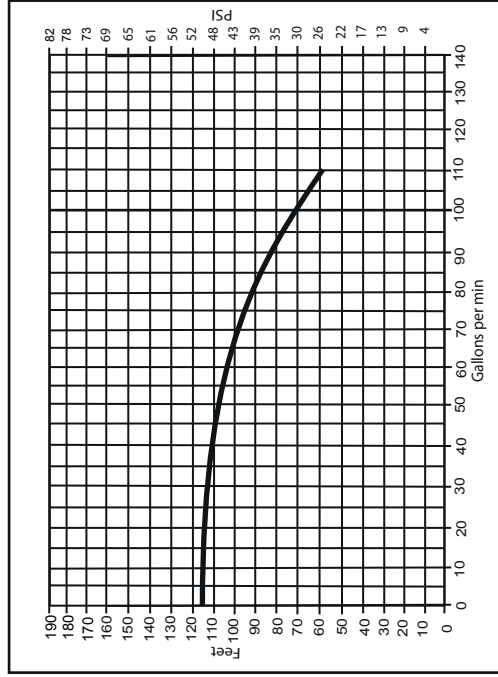
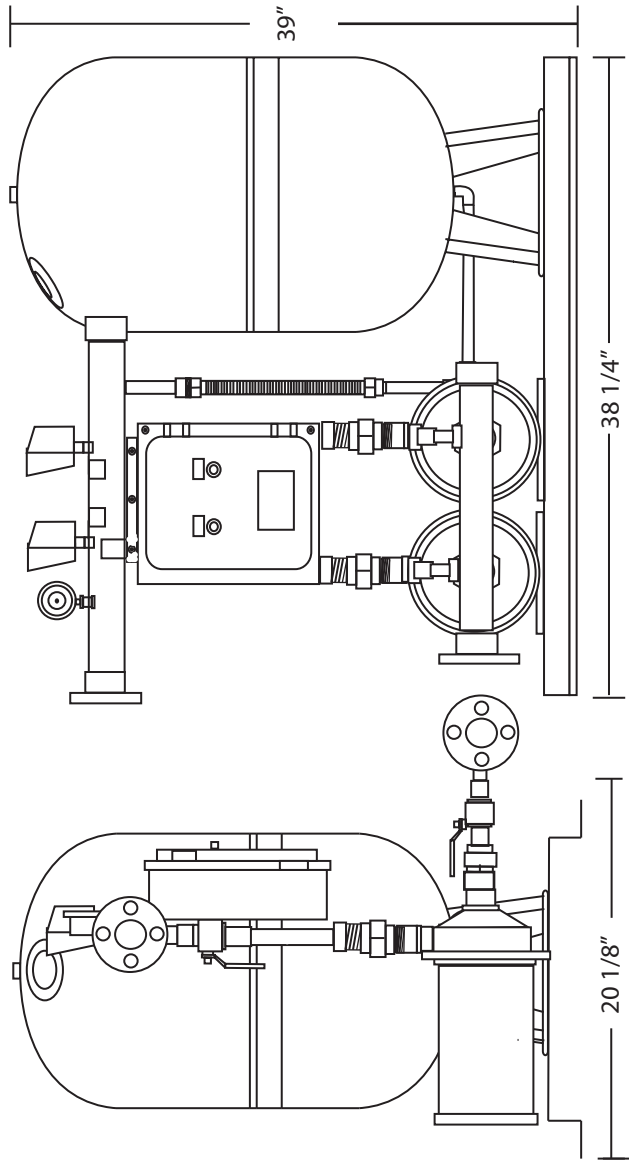



Aqua Pro Pump Systems

a Tomiko Inc. Company

MODEL: GEBD18040-32	
Pressure booster system for medium to larger sized commercial buildings. These systems come standard with NEMA 1 control panels, contactors, overloads, alternators, HOA switches, minimum run timers, and transformers in 3 phase models.	
DESIGN DATA	
Max Flow	336 GPM
Max Pressure Boost	51 PSI (117')
Pressure Range	5-80 PSI Pre Set 40/60
Adj. Minimum Run Timer	Pre Set 7-10 seconds
Pressure Gauge	2" Stainless Liquid Filled 0-160
Suction and Discharge	3"X 3"
Tank Capacity	40 gallon
Electrical Voltage and Phase	208/230/460/3
Motor	ODP
Horse Power	2-5HP
Max Pressure Rating	125 PSI
CONSTRUCTIONS MATERIALS	
Pump body	Stainless Steel
Impeller	Stainless Steel
Shaft	Stainless Steel
Seal	Carbon/Cermaic
Header	Copper
Ball Valves	Lead Free Brass
Check Valves	Lead Free Brass
Expansion Tank	Steel
Diaphragm	Butyl
Base Plate	Galvanized Steel
SUBMITTAL DATA	
JOB NAME	
LOCATION	
ENGINEER	
CONTRACTOR	
DISTRIBUTOR	
SALES REP	
All Systems Require Minimum of 10 PSI Incoming Pressure	
Aqua Pro Pump Systems	
sales@tomikoinc.com	

