



The World's Leading Producer of Air Movement Products

# Clothes Dryer Boosting

# Clothes Dryer Boosting... SOLVED!



If you have a dryer with long or complicated duct runs, S&P offers the perfect solution to increase dryer efficiency: the PV100x Dryer Booster Fan. The PV100x has been specifically designed to handle dryer boosting applications when overcoming long or complicated duct runs. This system helps save on drying time, moisture build-up, wear and tear on your dryer, and helps save on your electric bill. The centrifugal blade design is able to overcome extreme resistance from the most challenging installations. The PV-100x offers a fully enclosed motor, which ensures a long, trouble free life; thus making it the right choice for enhancing the performance of your clothes dryer.

Finally, a resolution. The PV-100x fan is available separately or as part of a kit that includes everything necessary for a hands-free operation. Once the system is installed you will no longer waste time, energy or unnecessary wear and tear on your dryer. The next step is to select which activation best fits your needs.

## How to activate the PV-100x fan for clothes dryer boosting Pressure Switches

Pressure switches are a viable method of fan activation and a good solution for many installations. The pressure switch senses the pressure differential in the duct created by the dryer operation, thus activating the fan. Conversely, when the dryer is deactivated, the pressure switch senses this differential and the fan is deactivated. S&P does not mount the pressure switches to the fan so that the most advantageous location for the pressure switch can be determined by the installer for ease of maintenance and accessibility. The pressure switch should not be installed too far from the dryer's exhaust outlet (no more than 15 feet optimally), this decreases the risk of not having sufficient detectable pressure.

## Current Sensors

Current sensors are S&P's "preferred" method of activation. They are "fail-safe" there is no maintenance required on the current sensor and they're easy to install. The current sensing device can be installed at the outlet (where the dryer plugs into the wall) or at the circuit breaker box. When the device senses current going to the dryer, it activates the fan and vice-versa. No thought! No maintenance! Our choice!

Both activation methods are available as accessories or in the S&P all inclusive dryer booster kits:

## KIT Dryer Boosting Kits



### DBF-100xp

#### Clothes Dryer Exhaust Booster Kit with Pressure Sensor Switch

This Premium Dryer Booster Kit Includes the Following Components:

1. PV-100x Duct Boosting Fan (142 CFM)
2. Air Pressure Sensing Switch with electronic cycle timing board
3. Fan Mounting Bracket



### DBF-100xc

#### Clothes Dryer Exhaust Booster Kit with Current Sensor

This Premium Dryer Booster Kit Includes the Following Components:

1. PV-100x Duct Boosting Fan (142 CFM)
2. CS-325 High Current Sensing Switch
3. Fan Mounting Bracket



## SWF - Sidewall Mount Exhaust Fan for Dryer Boosting



The sidewall unit can be paired with a current sensor or pressure switch when interior duct access in a home, apartment or townhouse is limited or difficult. The expanded exhaust grill allows for the easy passing of lint laden air. The SWF utilizes the same powerful motor as the PV-100x and is also suitable for duct runs up to 105 feet or up to 80 feet with 6 elbows. The low profile SWF fan is easy to install with an epoxy coating that can be painted to match the exterior of the building. The SWF also offers the same trusted 5 year warranty.



### NOTE

The PV-100x Dryer Booster fan is suitable for use with duct runs of up to 105 linear feet of 4" rigid duct or a maximum of 6 elbows and 80 feet.

## Model PV-100x Fan Specifications

### Warranty

Five (5) year limited warranty.

### Casing

- Manufactured from high grade pressed galvanized steel, with black baked enamel coating.
- Extra long inlet and discharge collars make installation quick and trouble free.
- Supplied with a strong galvanized steel mounting bracket.
- Supplied with a remote mounting, prewired wiring junction box.

### Wheel / Impeller

- Backward curved centrifugal type constructed of metal.
- Factory matched to an external rotor motor and dynamically balanced to eliminate vibration.

### Motor

- Totally enclosed permanent split capacitor start and run external rotor motors.
- 115V 60Hz (single phase) electrical connection.
- Permanently sealed, self lubricating precision ball bearings.
- Safety Thermal Overload Protection Cut-Out (Automatic Reset Type).
- All Models are suitable for working airstreams up to 140° F.

### Code Approval

- Independently safety tested by Intertek Laboratories, and are ETL Listed.
- Independently tested for Airflow Performance. The PV range is licensed to bear the AMCA seal for Air Performance.
- The PV product range is certified by the Home Ventilating Institute (HVI) for Air Performance.

## Model PV-100x Dimensions (inches/mm)

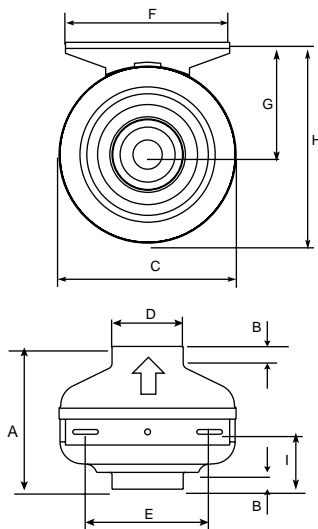

Model	A	B	C	D	E	F	G	H	I	Weight lbs(kgs)
PV-100x	7 5/8 194	1 25	9 1/2 241	3 7/8 98	6 11/16 170	8 7/8 225	6 1/16 154	10 13/16 275	3 1/4 83	7 3.0

### Air Performance

Model	Nom. RPM	Volts	Max. Watts	CFM v Static Pressure (SP) Ins. WG									Max. SP	Duct Dia. Ins.
				0"	0.125"	0.25"	0.375"	0.5"	0.75"	1.0"	1.25"	1.5"		
PV-100x	2880	115	84	153	142	130	120	111	96	80	63	34	1.85	4"

### Sound

Fan sound levels are measured in sones. At this time there are no sone level test standards available through HVI due to the fact that remote mounted fan noise levels are in proportion to the following: type of duct, length of duct, fan distance from the intake source and other miscellaneous factors. However it is generally accepted that remote mounted venting is usually quieter than standard (in room) venting.



Soler & Palau USA certifies that the PV range shown herein is licensed to bear the AMCA Seal. The ratings shown are based on tests and procedures performed in accordance with AMCA Publication 211 and comply with the requirements of the AMCA Certified Ratings Program.



## Model SWF-100x Dimensions (inches/mm)

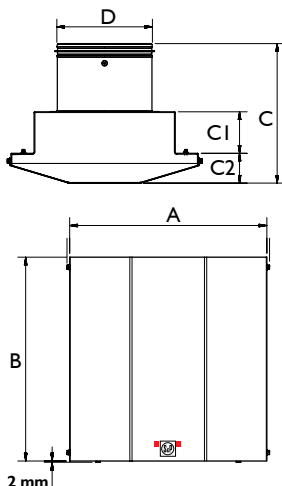

Model	A	B	C	C1	C2	D
SWF-100x	13 1/4 337	13 1/4 337	9 228	3 76	2 7/16 62	4 100

### Air Performance

Model	CFM vs. Static Pressure (SP) Ins. WG								
	0"	0.125"	0.25"	0.375"	0.5"	0.75"	1.0"	1.25"	1.5"
SWF-100X	171	162	152	142	118	90	66	46	28

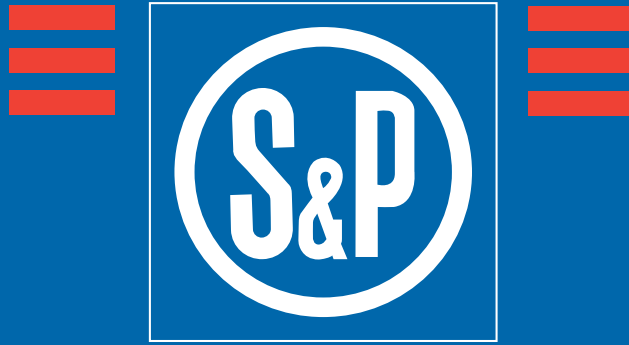

**Soler & Palau USA**  
6393 Powers Ave.  
Jacksonville, FL 32217  
800.961.7370  
800.961.7379  
[www.solerpalau-usa.com](http://www.solerpalau-usa.com)

**Soler & Palau Canada**  
61 A Baywood road  
Toronto, ON M9V 3Y8  
866.733.0233  
866.385.5346  
[www.solerpalaucanada.com](http://www.solerpalaucanada.com)