

DUCTLESS

# HV1000 R38/R50

## WHOLE HOUSE FAN



Cools homes up to 1,600 Sq ft

### FEATURES

- Quickly circulates 1000 CFM\* & cools the whole home
- Energy efficient & maintenance-free
- Mechanical self-sealing doors, available in R38 or R50 insulation value
- Easy to install both horizontally and vertically
- Fits 16" - 24" on-center joists | No joist-cutting required
- Controlled by SPST wall switch or spring-wound non-digital timer (not included with fan purchase)\*\*
- WiFi model available for convenient smartphone and smart home device operation
- Standard 3-year limited warranty with optional extended warranty

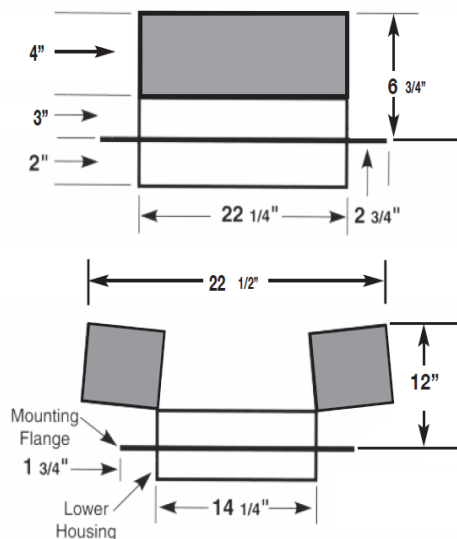

### SPECS

Airflow (CFM): **1000**

Electrical Requirements: **115/120 VAC, 60HZ**

Power Usage (watts): **70 W**

Doors Insulation Value: **R38 OR R50**

Rough Opening: **14 1/2" x 22 1/2"**

Interior Grille: **15 3/4" x 25 3/4" / WHITE METAL**

Operation: **1 SPEED / 30 SEC DOOR DELAY BEFORE FAN STARTS**

Attic Ventilation: REQUIRED **1.3 SQ FT NET FREE AREA** RECOMMENDED **1.7 SQ FT NET FREE AREA**

Weight: UNIT **18 LBS** SHIPPING **34 LBS**

Purchase Includes: **(1) HV1000, (1) HORIZONTAL GRILLE, (1) ELECTRICAL BOX COVER**

Optional Accessories: **VERTICAL GRILLE, "MUFFLER" ACOUSTIC PLENUM BOX**

*\*CFM rates were measured in a controlled test environment. Results will vary due to building construction.*

*\*\*All other controls will void the product warranty.*

