

GP500 INSTALLATION INSTRUCTIONS

BY

RadonAway™

3" OD Downspout

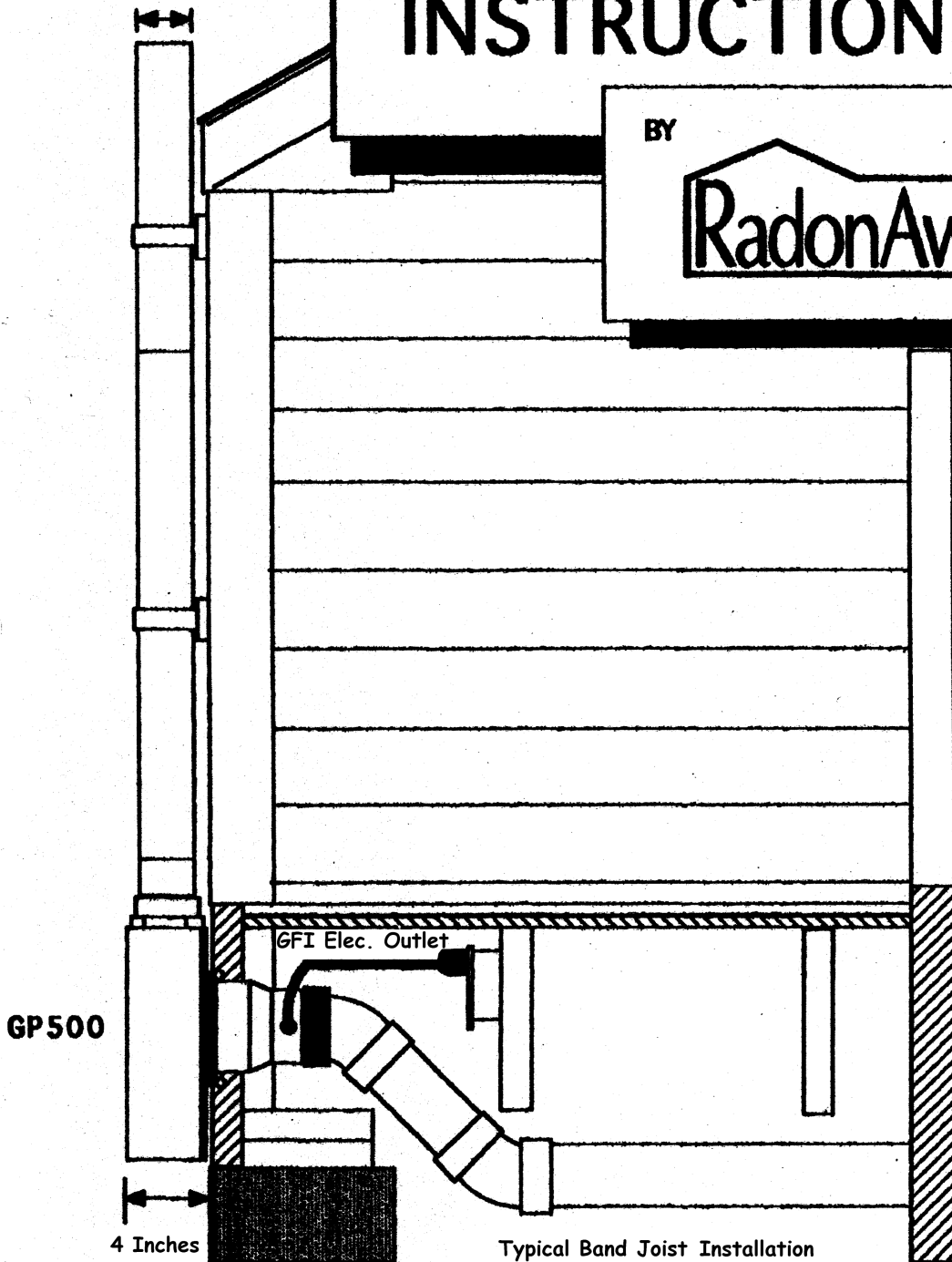

RadonAway, Inc Ward Hill, MA

P/N IN006 Rev I

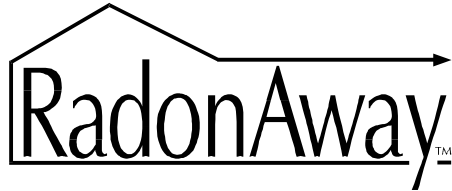

RadonAway Ward Hill, MA.

GP500 Fan Installation Instructions

Please Read and Save These Instructions.

DO NOT CONNECT POWER SUPPLY UNTIL FAN IS COMPLETELY INSTALLED. MAKE SURE ELECTRICAL SERVICE TO FAN IS LOCKED IN "OFF" POSITION. DISCONNECT POWER BEFORE SERVICING FAN.

1. **WARNING!** Do not use fan in hazardous environments where fan electrical system could provide ignition to combustible or flammable materials.
2. **WARNING!** Do not use fan to pump explosive or corrosive gases.
3. **WARNING!** Check voltage at the fan to insure it corresponds with nameplate.
4. **WARNING!** Normal operation of this device may affect the combustion airflow needed for safe operation of fuel burning equipment. Check for possible backdraft conditions on all combustion devices after installation.
5. **NOTICE!** There are no user serviceable parts located inside the fan unit.
Do NOT attempt to open. Return unit to the factory for service.
6. All wiring must be performed in accordance with the National Fire Protection Association's (NFPA) "National Electrical Code, Standard #70"-current edition for all commercial and industrial work, and state and local building codes. All wiring must be performed by a qualified and licensed electrician.
7. **WARNING!** Do not leave fan unit installed on system piping without electrical power for more than 48 hours. Fan failure could result from this non-operational storage.
8. **WARNING! TO REDUCE THE RISK OF FIRE, ELECTRIC SHOCK, OR INJURY TO PERSONS, OBSERVE THE FOLLOWING:**
 - a) Use this unit only in the manner intended by the manufacturer. If you have questions, contact the manufacturer.
 - b) Before servicing or cleaning unit, switch power off at service panel and lock the service disconnecting means to prevent power from being switched on accidentally. When the service disconnecting means cannot be locked, securely fasten a prominent warning device, such as a tag, to the service panel.



IN006 Rev I

INSTALLATION INSTRUCTIONS IN006 Rev I
For

DynaVac – General Series
GP500 p/n 23003-1

1.0 SYSTEM DESIGN CONSIDERATIONS

1.1 INTRODUCTION

The GP500 is intended for use by trained, professional Radon mitigators. The purpose of this instruction is to provide additional guidance for the most effective use of the GP500. This instruction should be considered as a supplement to EPA standard practices, state and local building codes and state regulations. In the event of a conflict, those codes, practices and regulations take precedence over this instruction.

1.2 ENVIRONMENTALS

The GP500 is designed to perform year-round in all but the harshest climates without additional concern for temperature or weather. For installations in an area of severe cold weather, please contact RadonAway for assistance. When not in operation, the GP500 should be stored in an area where the temperature is never less than 32 degrees F. or more than 100 degrees F. When the unit is turned off for extended periods of time the drain plug should be removed from the bottom of the unit.

1.3 ACOUSTICS

The GP500, when installed properly, operates with little or no noticeable noise to the building occupants. Insure a solid mounting for the GP500 to avoid structure-borne vibration or noise.

The velocity of the outgoing air must also be considered in the overall system design. In some cases the "rushing" sound of the outlet air may be disturbing. In these instances, the use of a RadonAway Exhaust Muffler is recommended.

1.4 GROUND WATER

In the event that a temporary high water table results in water at or above slab level, water may be drawn into the riser pipes thus blocking air flow to the GP500. The lack of cooling air may result in the GP500 cycling on and off as the internal temperature rises above the thermal cutoff and falls upon shutoff. Should this condition arise, the GP500 should be disconnected until the water recedes allowing for return to normal operation.

1.5 CONDENSATION & DRAINAGE

Condensation is formed in the piping of a mitigation system when the air in the piping is chilled below its dew point. This can occur at points where the system piping goes through unheated space such as an attic, garage or outside. The system design must provide a means for water to drain back to a slab hole to remove the condensation.

For GP500 piping, the following table provides the minimum recommended pipe diameter and pitch under several system conditions.

Pipe Diam.	Minimum Rise per Foot of Run*		
	@ 25 CFM	@ 50 CFM	@ 100 CFM
4"	1/8 "	1/4 "	3/8 "
3"	1/4 "	3/8 "	1 1/2 "

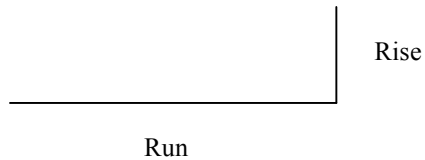

*Typical GP500 operational flow rate is 25 - 90 CFM. (For more precision, determine flow rate by using the chart in the addendum.)

The GP500 incorporates a unique condensation drain system which actively pumps water back to the inlet piping for drainage to a slab hole. It is required that the system piping provide a drop-off immediately at the inlet of the unit, as shown in Figure 1, to prevent reentrainment of condensation. If this is not possible the condensate drain tube may be extended to the point of drop off by slipping 5/16" ID tubing (available from RadonAway) over the drain tube.

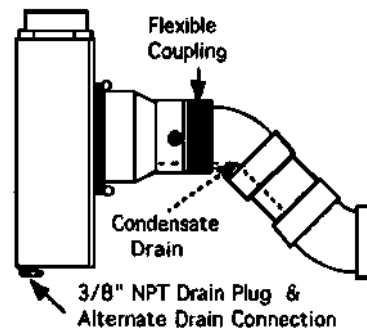

Figure 1

An alternative condensation drain may be provided using the 3/8" NPT fitting on the bottom of the unit. The alternative drain system must account for Radon leakage as the drain is under positive pressure. If the unit is installed and electrical power is removed for extended periods of time the drain plug should be removed to allow water to drain from the unit.

IMPORTANT: Do not overtighten drain plug! Do not use a wrench or tighten beyond finger tight. Apply sealant to threads if required.

1.6 "SYSTEM ON" INDICATOR

A U-Tube manometer or a vacuum alarm is recommended as a "System On" Indicator for affirmation of system operation.

1.7 SLAB COVERAGE

The GP500 can provide coverage up to 1000+ sq. ft. per slab penetration. This will, of course, depend on the sub-slab material in any particular installation and the diagnostic results. In general, the tighter the sub-slab material, the smaller the area covered per penetration. Additional suction points can be added as required. It is recommended that a small pit (5 to 10 gallons in size) be created below the slab at each suction hole.

1.8 ELECTRICAL WIRING

The GP500 plugs into a standard 115VAC outlet. The use of a Ground Fault Interrupter circuit (GFI) is recommended for all installations and required for outdoor or wet installations. All wiring must be performed in accordance with the National Fire Protection Association's (NFPA) "National Electrical Code, Standard #70"-current edition for all commercial and industrial work, and state and local building codes. All wiring must be performed by a qualified and licensed electrician. Ensure that all exterior electrical boxes are outdoor rated and properly sealed to prevent water penetration into the box. A means, such as a weep hole, is recommended to drain the box.

1.9 SPEED CONTROLS

The use of electronic speed controls on the GP500 is NOT recommended.

2.0 INSTALLATION

2.1 A.C. POWER CONNECTION

See Section 1.8. The GP500 requires an 18 gauge, 3 wire SJ power cord, RadonAway p/n 27003 or equivalent. For proper seal, the cord diameter should be 5/16". To install:

- 1) Prepare the power cord by stripping jacket and insulation as shown in Figure 2.
- 2) Loosen sealing nut on electrical inlet by turning counterclockwise.
- 3) Insert power cord and route as shown in Figure 3.
- 4) Fasten power cord with cable clamp provided.

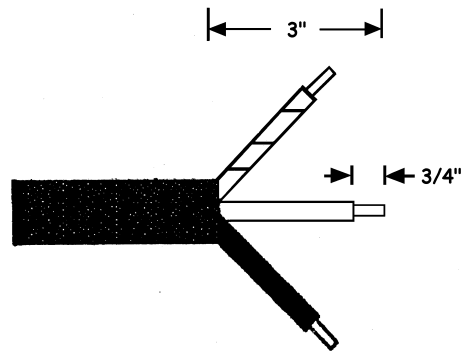

Figure 2.

Figure 2

- 5) **IMPORTANT:** Tighten sealing nut by turning clockwise. Hand tight is adequate to provide seal.
- 6) Connect wiring with wire nuts provided, observing proper connections:

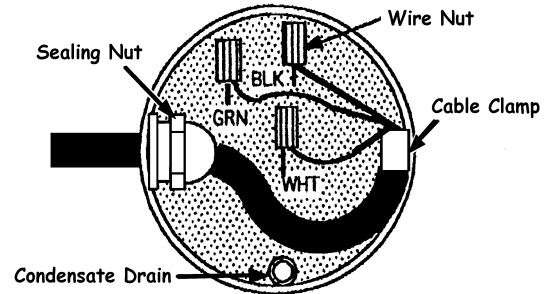

Figure 3.

GP500 Wire	Connection
Green	Ground
Black	AC Hot
White	AC Common

- 7) Tape over wire and wire nut with electrical tape to seal out moisture. A rubber splicing tape or self-fusing silicone tape provide best moisture seal.

2.2 OUTDOOR (BAND JOIST OR SIDEWALL)

- 1) Locate site for GP500 mounting. Use the diagram in Figure 4 to assist in locating the inlet hole for the unit.
- 2) Drill a 5.25" or 5.50" hole through the band joist or sidewall.

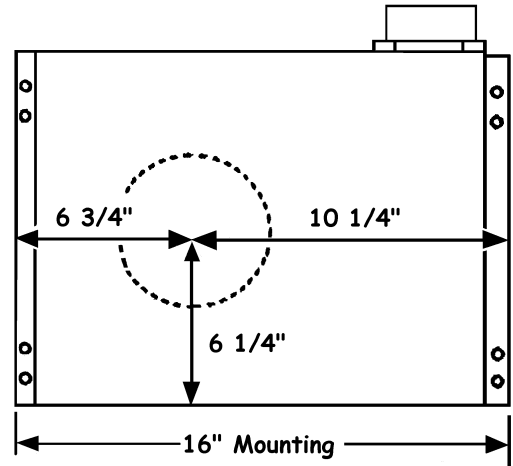

Figure 4

- (Use Figure 5 as a Guide for 3-6):
- 3) Apply a liberal bead of silicone caulk to the sealing ring.
 - 4) Carefully feed power cord through hole and install the unit into the hole drilled.
 - 5) Insure the unit is level and plumb.
 - 6) Insure the inlet of the fan does not contact any building surface when mounting to avoid noise or vibration transmission.
 - 7) Secure unit to sidewall with four (4) #6 x 2.0" drywall screws provided. Use nylon washers provided under the screw heads to prevent marring the finish.
 - 8) Complete piping run, providing flexible couplings or other means of disconnect for servicing the unit.

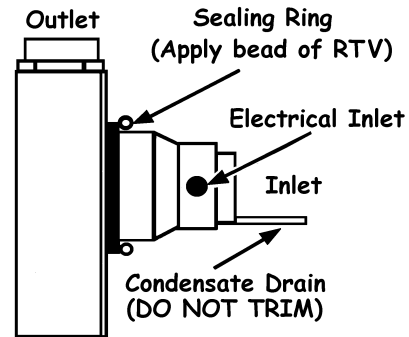

Figure 5

Under certain circumstances, a flexible pipe coupling, RadonAway p/n 79019-1, may ease installation. This may be particularly true of gable side installations where the system piping runs perpendicular to the floor joists. Install the pipe coupling as shown in Figure 6, making certain to avoid sharp bends or kinks in the piping. (TIP: You may connect the pipe coupling to the GP500 before installing the unit through the band joist.)

2.3 MUFFLER INSTALLATION (Optional)

Install the vent muffler assembly in the selected location in the outlet ducting. Solvent weld all connections. The muffler is normally installed at the end of the vent pipe.

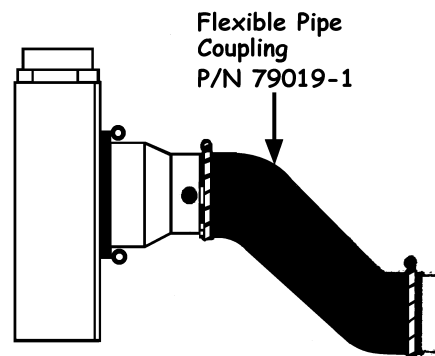

Figure 6

2.4 OPERATION CHECKS

____ Verify all connections are tight and leak-free.

____ Insure the GP500 and all ducting is secure and vibration-free.

____ Verify system vacuum pressure with Manometer or other pressure gauge. Insure vacuum pressure is less than 3.8" WC (based on sea-level operation, at higher altitudes reduce by about 4% per 1000 Feet). If this is exceeded, increase the number of suction points.

____ Verify Radon levels by testing to EPA protocol.

ADDENDUM

PRODUCT SPECIFICATIONS

The following chart shows fan performance for the GP500:

	Typical CFM vs Static Suction WC						
	1.0"	1.5"	2.0"	2.5"	3.0"	3.5"	4.0"
GP500	88	80	74	65	54	28	14

Power: 70 - 130 watts (varies with actual load conditions) @ 115 VAC

Inlet/Outlet: 3" PVC

Mounting: Brackets for vertical mount on bandjoist or sidewall.

(16" Mounting Centers)

Outdoor installations - GP500 mounts flush to wall projecting only 4" with inlet duct passing through the sidewall or band joist. Power cord is on the inside simplifying connection.

Weight: 20 lbs.

Recommended ducting: 3" Schedule 20/40 PVC Pipe or attractive thin walled 3" O.D. PVC

Downspout available from RadonAway

Storage temperature range: 32 - 100 degrees F.

Thermally protected

Size: 17" x 12" x 4" (plus 7" inlet duct)

IMPORTANT INSTRUCTIONS TO INSTALLER

Inspect the GP500 Fan for shipping damage within 15 days of receipt. Notify **RadonAway of any damages immediately**. Radonaway is not responsible for damages incurred during shipping. However, for your benefit, Radonaway does insure shipments.

There are no user serviceable parts inside the fan. **Do not attempt to open**. Return unit to factory for service.

Install the GP500 Fan in accordance with all EPA standard practices, and state and local building codes and state regulations.



WARRANTY

Subject to any applicable consumer protection legislation, RadonAway warrants that the GP500 Fan (the "Fan") will be free from defects in materials and workmanship for a period of two (2) years from the date of manufacture (the "Warranty Term"). Outside the Continental United States and Canada the Warranty Term is one (1) year from the date of manufacture.

RadonAway will replace any Fan which fails due to defects in materials or workmanship. The Fan must be returned (at owner's cost) to the RadonAway factory. Any Fan returned to the factory will be discarded unless the Owner provides specific instructions along with the Fan when it is returned regardless of whether or not the fan is actually replaced under this warranty. Proof of purchase must be supplied upon request for service under this Warranty.

This Warranty is contingent on installation of the Fan in accordance with the instructions provided. This Warranty does not apply where any repairs or alterations have been made or attempted by others, or if the unit has been abused or misused. Warranty does not include damage in shipment unless the damage is due to the negligence of RadonAway.

RadonAway is not responsible for installation, removal or delivery costs associated with this Warranty.

EXCEPT AS STATED ABOVE, THE GP500 FANS ARE PROVIDED WITHOUT WARRANTY OF ANY KIND, EITHER EXPRESS OR IMPLIED, INCLUDING, WITHOUT LIMITATION, IMPLIED WARRANTIES OF MERCHANTABILITY AND FITNESS FOR A PARTICULAR PURPOSE.

IN NO EVENT SHALL RADONAWAY BE LIABLE FOR ANY DIRECT, INDIRECT, SPECIAL, INCIDENTAL, OR CONSEQUENTIAL DAMAGES ARISING OUT OF, OR RELATING TO, THE FAN OR THE PERFORMANCE THEREOF. RADONAWAY'S AGGREGATE LIABILITY HEREUNDER SHALL NOT IN ANY EVENT EXCEED THE AMOUNT OF THE PURCHASE PRICE OF SAID PRODUCT. THE SOLE AND EXCLUSIVE REMEDY UNDER THIS WARRANTY SHALL BE THE REPAIR OR REPLACEMENT OF THE PRODUCT, TO THE EXTENT THE SAME DOES NOT MEET WITH RADONAWAY'S WARRANTY AS PROVIDED ABOVE.

For service under this Warranty, contact RadonAway for a Return Material Authorization (RMA) number and shipping information. No returns can be accepted without an RMA. If factory return is required, the customer assumes all shipping cost to and from factory.

RadonAway
3 Saber Way
Ward Hill, MA 01835
TEL. (978) 521-3703
FAX (978) 521-3964

Record the following information for your records:

Serial No. _____
Purchase Date _____