

# Installation and Operation Manual

## FSD Series

Inline Mixed Flow Square Fans

### PARTS IN THE BOX

- Inline Fan FSD, 1 pc
- Mounting Brackets, 4 pcs
- Inline and Operations Manual, 1 pc

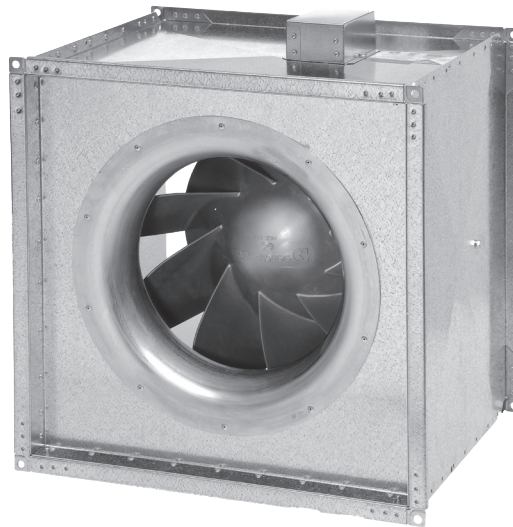

REGISTER\* THIS PRODUCT TO  
INCREASE YOUR PRODUCT  
WARRANTY BY AN EXTRA YEAR

[registration.fantech.app](https://registration.fantech.app)



\* in USA only



Fantech Inc. certifies that the FSD Series shown herein is licensed to bear the AMCA Seal. The ratings shown are based on tests and procedures performed in accordance with AMCA Publication 211 and AMCA Publication 311, and comply with the requirements of the AMCA Certified Ratings Program.

United States

Tel.: 800 747 1762

Canada

Tel.: 800 565 3548

Latinoamérica

Tel.: +52 55 1328 7328



**fantech**<sup>®</sup>  
a systemair company

Note	Warning / Important note	Information	Technical information	Practical tip



**Before installation, servicing or cleaning unit, switch power off at service panel and lock the service disconnecting means to prevent power from being switched on accidentally. When the service disconnecting means cannot be locked, securely fasten a prominent warning device, such as a tag, to the service panel.**

1. The compactness and adaptability of the FKD/KD Series fans permit easy installation. The fans are shipped fully assembled and can be mounted at any angle. For various mounting, see figures on the following page.
2. Because this unit has rotating parts, safety precautions should be exercised during all phases of installation, operation and maintenance.
3. CAUTION: For general ventilation use only, do not use to exhaust hazardous or explosive material and vapors.

**For indoor installation only.**

4. Remove unit from package and inspect within 15 days after receipt. If damaged, report damage to carrier. Do not operate this unit with visible damage to the blower or impeller assembly.
5. CAUTION: This unit has an unguarded impeller. Do not use in locations readily accessible to people or animals.

**WEAR HAND PROTECTION AND STAY CLEAR OF SHARP EDGES!**

6. Screen guards must be installed within reach of personnel, within (7) feet of the working area, or when advisable for safety.
7. PLEASE read the entire manual before installing



**Make a scan of the QR code above to access Fantech's warranty in English. Includes a 5y warranty.**

If additional support is needed to retrieve the warranty, visit [fantech.net](http://fantech.net); call (800) 747-1762 (US), (800) 565-3548 (Canada), or +52 55 1328-7328 (Latin America); email [support@fantech.net](mailto:support@fantech.net); or mail us at 10048 Industrial Blvd, Lenexa, KS 66215 United States or at 50 Kanalläkt Way, Bouctouche, NB E4S 3M5 Canada.

## WARNINGS

**DO NOT CONNECT POWER SUPPLY until fan is completely installed. Make sure electrical service to the fan is in the locked "OFF" position.**

1. All fans are suitable for use with solid-state speed control. Three phase units must be wired through a motor contactor.
2. WARNING! TO REDUCE THE RISK OF FIRE, ELECTRIC SHOCK, OR INJURY TO PERSONS - OBSERVE THE FOLLOWING:
  - a. Use this unit in the manner intended by the manufacturer. If you have any questions, contact your manufacturer's representative or contact us directly.
  - b. CAUTION: Before installation, servicing or cleaning unit, switch power off at service panel and lock the service disconnection means to prevent power from being switched on accidentally. When the service disconnection means cannot be locked, securely fasten a prominent warning device, such as a tag, to the panel.
  - c. Installation work and electrical wiring must be done by qualified person(s) in accordance with all applicable codes and standards, including fire-rated construction.
3. Sufficient air is needed for proper combustion and exhausting of gases through the flue (chimney) of fuel burning equipment to prevent back drafting. Follow the heating equipment manufacturer's guideline and safety standards such as those published by the National Fire Association (NFPA), and the American Society for Heating, Refrigeration and Air-Conditioning Engineers (ASHRAE), and the local code authorities.
  - a. When cutting or drilling into wall and ceiling, do not damage electrical wiring and other hidden utilities.
  - b. Ducted exhaust fans must always be vented to the outdoors.
  - c. If this unit is to be installed over a tub or shower, it must be marked as appropriate for the application and be connected to a GFCI (Ground Fault Circuit Interrupter) - protected branch circuit.
  - d. Use only on GFCI Protected Receptacles.
  - e. Do not use an extension cord with this fan.
  - f. If a power cord is connected, do not install this fan behind a suspended or structural wall, ceiling, or floor.
  - g. NEVER place a switch where it can be reached from a tub or shower.
4. WARNING! Check voltage at the fan to see if it corresponds to the motor name plate.

## MOUNTING ILLUSTRATION 1

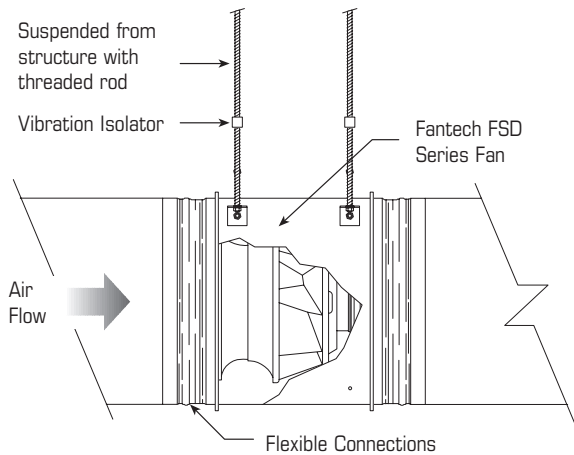

### Please follow all applicable codes when installing this unit

1. Determine the fan location and preferred mounting method.



When mounting fan, use all four included brackets and plug any unused holes.

2. Install included mounting brackets onto fan.

3. Place fan in position.

4. When fan is in position, support fan with the temporary fixture.

5. If possible, use vibration isolation mounts (not included) to connect fan to support structure.

6. Once fan is secure, remove temporary fixture.

7. If possible, use flexible connectors (not included) to make duct connections.

8. Using the appropriate diagram on the next page, make electrical connections

## MOUNTING ILLUSTRATION 2

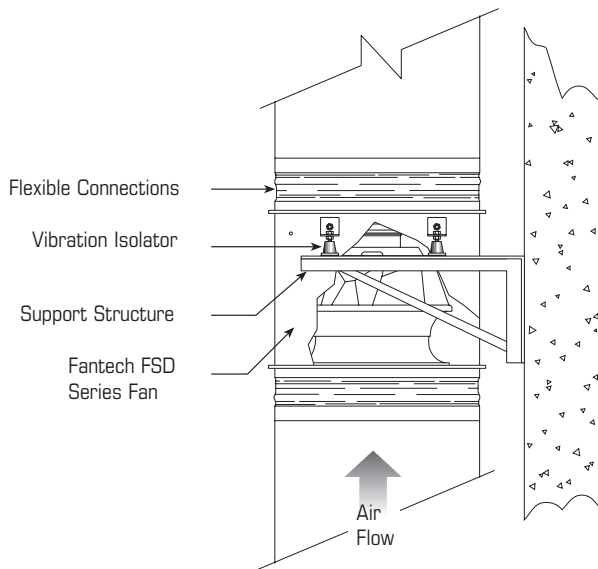

### Please follow all applicable codes when installing this unit

1. Determine the fan location and preferred mounting method.



When mounting fan, use all four included brackets and plug any unused holes.

2. Install included mounting brackets onto fan.

3. Place fan in position.

4. When fan is in position, support fan with the temporary fixture.

5. If possible, use vibration isolation mounts (not included) to connect fan to support structure.

6. Once fan is secure, remove temporary fixture.

7. If possible, use flexible connectors (not included) to make duct connections.

8. Using the appropriate diagram on the next page, make electrical connections

## MOUNTING ILLUSTRATION 3

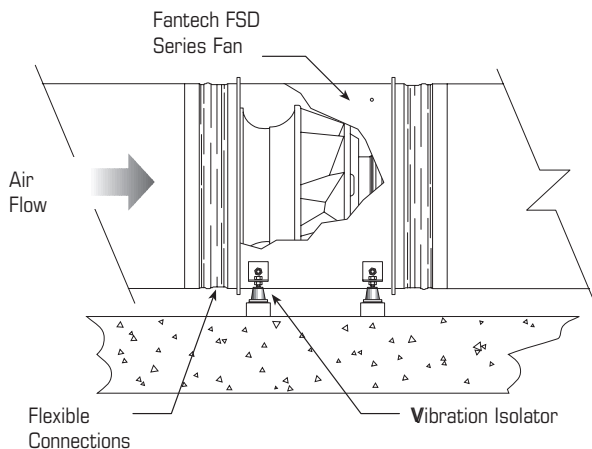

### Please follow all applicable codes when installing this unit

1. Determine the fan location and preferred mounting method.



When mounting fan, use all four included brackets and plug any unused holes.

2. Install included mounting brackets onto fan.

3. Place fan in position.

4. When fan is in position, support fan with the temporary fixture.

5. If possible, use vibration isolation mounts (not included) to connect fan to support structure.

6. Once fan is secure, remove temporary fixture.

7. If possible, use flexible connectors (not included) to make duct connections.

8. Using the appropriate diagram on the next page, make electrical connections

# DIMENSIONS AND WIRING

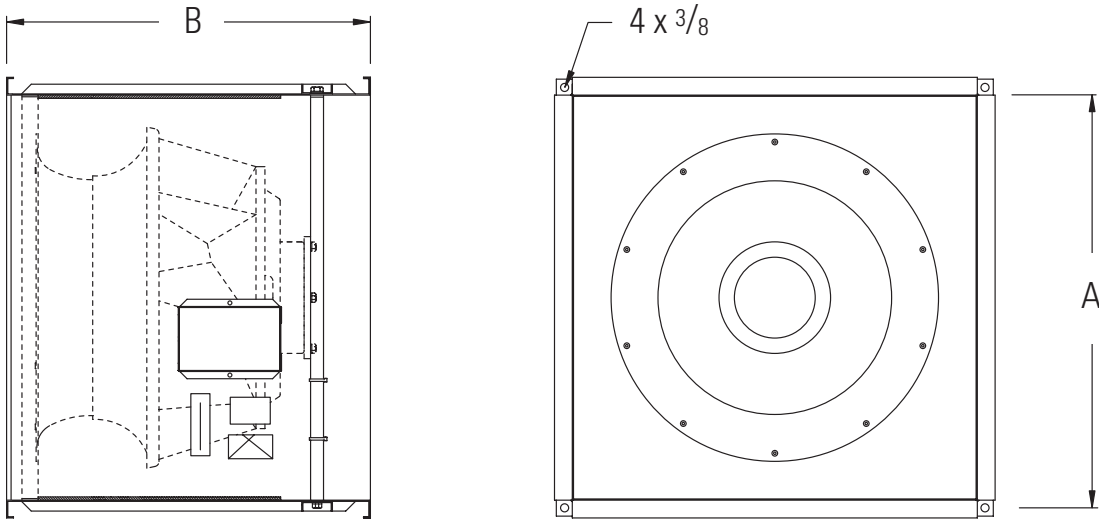

Model	A	B	Weight
FSD 18	17 <sup>5</sup> / <sub>8</sub>	15 <sup>3</sup> / <sub>4</sub>	55
FSD 20	19 <sup>3</sup> / <sub>4</sub>	17 <sup>3</sup> / <sub>4</sub>	65
FSD 22	21 <sup>1</sup> / <sub>2</sub>	19	95
FSD 26	26	20	135

All dimensions in inches. Weight in pounds.

## WIRING

- GNYE - Green/Yellow**    **BN - Brown**    **RD - Red**
- BU - Blue**                **GY - Grey**        **X - Not Applicable**
- BK - Black**                **OG - Orange**

### 120/230 Volt Single Phase Fans FSD: 18 and 20

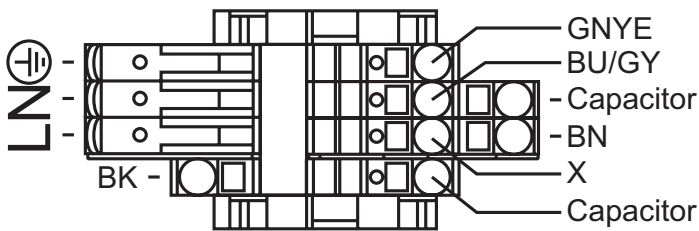

### 120 Volt Single Phase Fans FSD: 22



### 230/460 Volt Three Phase Fans FSD: 26

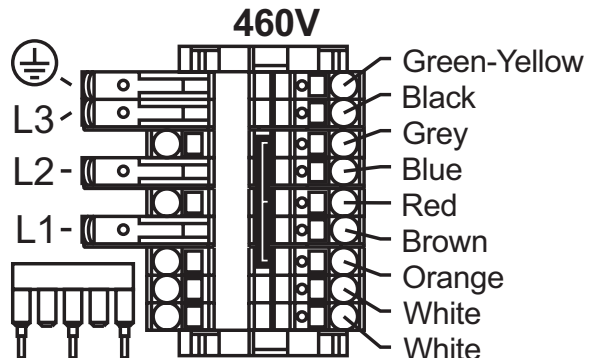
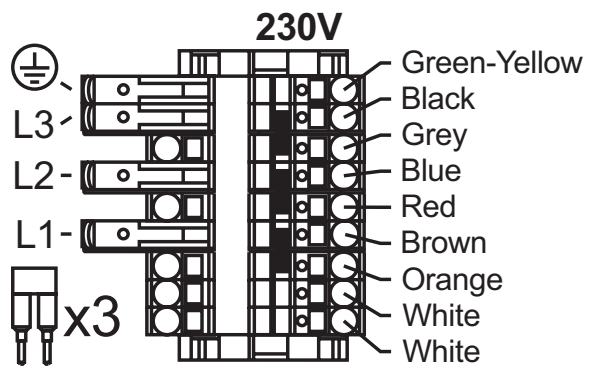

# NOTES

# NOTES

# NOTES

Fantech reserves the right to make technical changes.  
For updated documentation please refer to [www.fantech.net](http://www.fantech.net)

Fantech®