

FB Series

Inline Filter Box with Merv 13 Filter

Product #: 40304



READ AND SAVE THESE INSTRUCTIONS!

Building sciences research has shown that highly efficient filtration of the outside air before it is delivered to the home is one of the best ways to reduce the level of particles suspended in your home's air. **FEATURES** 80-90% Efficiency Designed to meet the air filtration efficiency criteria required to gain points toward certification in the Leadership in Energy and Environmental Design (LEEDs) Green Building rating system.

Specification

Cabinet

- 22 galvanized steel
- 10" (250mm) depth x 8" (200mm) height x 20-1/2" (525mm) length
- 6" (150mm) diameter plastic duct connections
- Beige baked enamel powder paint
- Neoprene door seal
- Access door removed with thumb screws

Filter

- Pleated, non-washable
- 10"x20"x1" (nominal)
- Exact dimensions : 9-1/2" x 19-1/2" x 3/4"
- 240 x 495 x 19 mm
- Rated MERV13 (Arrestance of >98% based on Standard 52.1)
- Listed UL 900 for the US and Canada

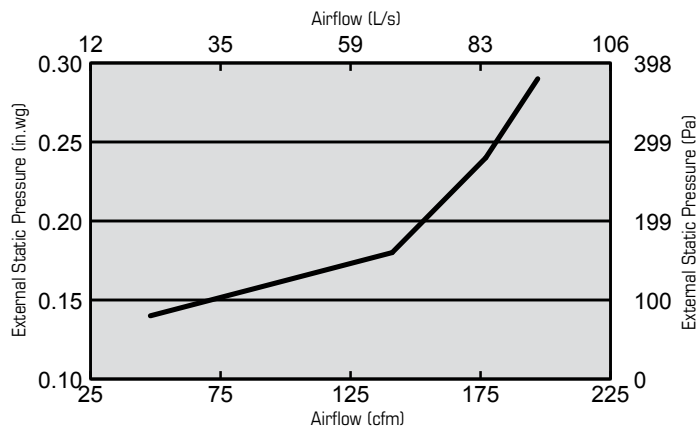

Airflow & Pressure Drop Installation



Disconnect power to any appliances or fans to which you will be connecting the FB6. Failure to do so may result in injury.

- Seal unused mounting holes with aluminum tape or adhesive to prevent air leak
- Install the FB6 between your HRV or inline fan and your home's ducting.
- Make sure access door is oriented so you can easily check the filter and replace it when needed.
- Use aluminum tape or an adhesive to seal the ducts onto the duct connections. Duct tape eventually fills with dust and loses its adhesive.
- If cold air from the outside will pass through the FB6 and it is located in a warm area, condensation may occur. Insulate the cabinet if this is a concern in your installation.
- If warm, humid air will pass through the FB6 and it is located in a cool air-conditioned area, condensation may occur inside the cabinet. Insulate the cabinet if this is a concern in your installation.
- Open the access panel and check that the filter is in place and any packaging is removed.

Maintenance

Replace your filter every three (3) months. Adjust your maintenance schedule based on how dirty the filter is when you replace it. If the inside of the cabinet is dirty, wipe with a clean, damp cloth. Enter the date the filter was installed then the date of each replacement filter. (See back page for chart)

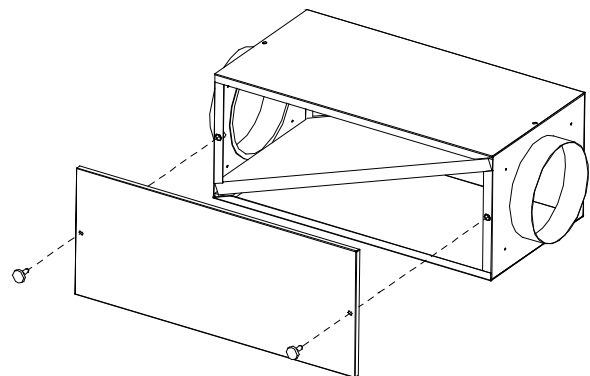

Warranty

Five (5) Year Warranty

This warranty supersedes all prior warranties

DURING ENTIRE WARRANTY PERIOD:

Fantech will repair or replace any part which has a factory defect in workmanship or material. Product may need to be returned to the Fantech factory, together with a copy of the bill of sale and identified with RMA number.

FOR FACTORY RETURN YOU MUST:

- Have a Return Materials Authorization (RMA) number. This may be obtained by calling Fantech either in the USA at 1.800.747.1762 or in CANADA at 1.800.565.3548. Please have bill of sale available.
- The RMA number must be clearly written on the outside of the carton, or the carton will be refused.
- All parts and/or product will be repaired/replaced and shipped back to buyer; no credit will be issued.

OR

The Distributor may place an order for the warranty part and/or product and is invoiced. The Distributor will receive a credit equal to the invoice only after product is returned prepaid and verified to be defective.

FANTECH WARRANTY TERMS DO NOT PROVIDE FOR REPLACEMENT WITHOUT CHARGE PRIOR TO INSPECTION FOR A DEFECT. REPLACEMENTS ISSUED IN ADVANCE OF DEFECT INSPECTION ARE INVOICED, AND CREDIT IS PENDING INSPECTION OF RETURNED MATERIAL. DEFECTIVE MATERIAL RETURNED BY END USERS SHOULD NOT BE REPLACED BY THE DISTRIBUTOR WITHOUT CHARGE TO THE

END USER, AS CREDIT TO DISTRIBUTOR'S ACCOUNT WILL BE PENDING INSPECTION AND VERIFICATION OF ACTUAL DEFECT BY FANTECH.

THE FOLLOWING WARRANTIES DO NOT APPLY:

- Damages from shipping, either concealed or visible. Claim must be filed with freight company.
- Damages resulting from improper wiring or installation.
- Damages or failure caused by acts of God, or resulting from improper consumer procedures, such as:
 1. Improper maintenance
 2. Misuse, abuse, abnormal use, or accident, and
 3. Incorrect electrical voltage or current.
- Removal or any alteration made on the Fantech label control number or date of manufacture.
- Any other warranty, expressed, implied or written, and to any consequential or incidental damages, loss or property, revenues, or profit, or costs of removal, installation or reinstallation, for any breach of warranty.

WARRANTY VALIDATION

- The user must keep a copy of the bill of sale to verify purchase date.
- These warranties give you specific legal rights, and are subject to an applicable consumer protection legislation. You may have additional rights which vary from state to state.

Date FB6 was installed	Date FB6 filter was replace	Date FB6 filter was replace
Date FB6 filter was replace		

Contacts

Submitted by:	Date:
Quantity: Model:	Project #:
Comments:	
Location:	
Architect:	
Engineer:	Contractor:

Distributed by:

United States 10048 Industrial Blvd. • Lenexa, KS 66061 • 1.800.747.1762 • www.fantech.net
 Canada 50 Kanafllakt Way • Bouctouche, NB E4S 3M5 • 1.800.565.3548 • www.fantech.net

Fantech, reserves the right to modify, at any time and without notice, any or all of its products' features, designs, components and specifications to maintain their technological leadership position.